

THE OLIVET COLLEGE
WING-T RUNNING GAME





EXCELLENCE

- **DEDICATION TO EXCELLENCE SHOULD DISTINGUISH OUR EFFORTS IN FOOTBALL AND SHOULD BE REFLECTED IN THE PERFORMANCE OF OUR TEAM. INDIVIDUALLY AND COLLECTIVELY, WE STRIVE TO GIVE OUR ALL AND THEREBY REALIZE OUR BEST POSSIBILITIES.**

TEAMWORK

- **IF THERE IS ONE CONCEPT THAT DRIVES US, IT IS OUR DEDICATION TO WINNING IN THE BROADEST POSSIBLE SENSE. WE COMPETE TO WIN – AS INDIVIDUALS, AS TEAM MEMBERS AND AS REPRESENTITIVES OF THIS GREAT COLLEGE. WE CLEARLY UNDERSTAND THAT THE SUCCESS OF ANY ONE PERSON IS THE RESULT OF A DEDICATED EFFORT ON THE PART OF MANY PEOPLE. SO, WHILE WE ARE QUICK TO RECOGNIZE INDIVIDUAL PERFORMANCE, WE ARE EVEN QUICKER TO CELEBRATE ACHIEVEMENTS OF THE TEAM.**



TEN COMMANDMENTS **OF OFFENSE:**

- FAKES TO THE *EXTREME*.
- **NON-STOP BLOCKING** FROM THE SNAP TO THE ECHO OF THE WHISTLE.
- GREAT FUNDAMENTALS (**IF WE DON'T COACH IT – WE DON'T GET IT**).
- FIRST LEVEL (LOS) BLOCK **EVERY DEFENSE** WE SEE.
- SECOND LEVEL (DOWNFIELD) **PHYSICAL BLOCKING WITH GREAT EFFORT**.
- COUNTER AND REVERSE ACTION (**TO DESTROY PURSUIT**).
- **GREAT PLAY-ACTION PASSING (RUN/PASS OPTION)**.
- THROW AND CATCH *ON THE RUN*.
- **BLOCK AGGRESSIVELY** ON PASSING PLAYS.
- ACCEPT REPETITION WITH *ENTHUSIASM*.



WING-T PHILOSOPHY

- **THE WING-T OFFENSE IS DESIGNED TO SCORE POINTS WHILE AT THE SAME TIME CONTROLLING THE BALL, FIELD POSITION, AND WEARING DOWN, BOTH PHYSICALLY AND MENTALLY, THE OPPONENT'S DEFENSE.**
- **IT IS IMPORTANT THAT WE OBTAIN A BALANCE BETWEEN THE RUN AND THE PASS TO AVOID BECOMING TOO PREDICTABLE. THEREFORE, WE WILL EMPLOY A PLAY-ACTION PASSING ATTACK WHICH COMPLIMENTS OUR RUN GAME.**
- **FOR OUR OFFENSE TO BE SUCCESSFUL OUR LINEMEN MUST GET OFF THE BALL AND SUSTAIN THEIR BLOCKS FOR AT LEAST TEN STEPS. OUR BACKS MUST CARRY OUT THEIR FAKES FOR AT LEAST 20 YARDS DOWN FIELD. THEREFORE, CONSIDERABLE AMMOUNT OF TIME WILL BE SPENT IN PRACTICE ON THE FUNDAMENTALS OF THIS OFFENSE.**

WHY THE WING-T?

- **I KNOW IT.**
- **I HAVE CONFIDENCE IN IT.**
- **I CAN JUSTIFY IT WITH STATISTICS.**
- **IT FITS ALL TYPES OF PERSONEL.**
- **SMALL LINEMEN CAN BE SUCCESSFUL IN THE OFFENSE.**
- **YOU GET GREAT DOUBLE-TEAM, TRAPS AND KICK-OUT BLOCKS.**
- **YOU CAN SPREAD THE WEALTH WITH A FOUR-BACK ATTACK.**
- **IT IS A TOTALLY BALANCED OFFENSE.**
- **THIS STYLE OF OFFENSE ATTACKS DEFENSES.**
- **IT CREATES CONFLICTS FOR OPPOSING DEFENSES.**
- **IT HAS GREAT MIS-DIRECTION AND DECEPTION, SLOWING PURSUIT.**
- **IT IS A CONSISTENT BALL CONTROL OFFENSE.**
- **IT'S NOT SUBJECT TO BAD WEATHER.**
- **IT'S A LOW TURNOVER OFFENSE.**
- **IT EMPLOYS A GREAT RUN/PASS OPTION ATTACK.**

2002 NCAA RUSHING LEADERS

<u>COLLEGE</u>	<u>DIV.</u>	<u>ATT.</u>	<u>YARDS</u>	<u>YDS/ATT.</u>	<u>YDS/GM</u>
• GEORGIA SOUTH.	1AA	859	5407	6.29	386.2
• SPRINGFIELD	III	583	3567	6.11	356.7
• WILLAMETTE	III	561	3500	6.23	350.0
• CARSON-NEWMAN	II	636	4503	7.0	346.4
• WOFFORD	IAA	752	4106	5.46	342.1
• CONCORDIA (MN)	III	493	3228	6.54	322.8
• SALSBURY STATE	III	595	3450	5.79	313.6
• AIR FORCE	IA	786	4001	5.09	307.7
• AUGUSTANA	III	535	2709	5.06	301.0
• <i>OLIVET COLLEGE</i>	<i>III</i>	<i>554</i>	<i>2682</i>	<i>4.84</i>	<i>298.0</i>

2003 NCAA RUSHING LEADERS

<u>COLLEGE</u>	<u>DIV.</u>	<u>ATT.</u>	<u>YARDS</u>	<u>YDS/GM</u>
• SPRINGFIELD (MA)	III	646	3943	394.4
• <i>OLIVET COLLEGE</i>	<i>III</i>	<i>616</i>	<i>3851</i>	<i>385.1</i>
• CARSON-NEWMAN	II	640	3889	353.5
• WILLAMETTE (OR)	III	513	3458	345.8
• GEORGIA SOUTH	IAA	664	3692	335.6
• RHODE ISLAND	IAA	648	3660	332.7
• BRIDGEWATER ST.	III	504	2961	329.0
• NICHOLS STATE	II	566	3251	325.1
• HEDERSON STATE	II	665	3531	321.0
• MAINE MARITIME	III	534	2872	319.1



OFFENSIVE GOALS

- **OUR OFFENSE HAS FIVE MAIN GOALS THAT MUST BE ACHIEVED EACH GAME TO ENSURE SUCCESS.**
- **SCORE. WE WANT TO SCORE EVERY TIME WE HAVE THE BALL.**
- **CONTROL THE FOOTBALL. PLAY POSSESSION FOOTBALL AND CONTROL THE FIELD POSITION AND CLOCK.**
- **PRESSURE THE DEFENSE WITH TWO BASIC THREATS – THE RUN AND THE PASS.**
- **ATTACK THE ENTIRE FIELD, BOTH HORIZONTALLY AND VERTICALLY, THUS SPREADING THE OPPONENT’S DEFENSE.**
- **AVOID MENTAL MISTAKES, MISSED ASSIGNMENTS, PENALTIES AND TURNOVERS.**

IF YOU ARE GOING TO RUN THIS OFFENSE:

- **YOU MUST BE 100% COMMITTED TO IT.**
- **YOU CANNOT COACH MEDIOCRITY.**
- **YOU MUST HAVE SIMPLICITY AND YOU MUST HAVE A TREMENDOUS AMOUNT OF REPETITION. DO A FEW THINGS WELL.**
- **YOU MUST MEASURE AND CRITIQUE YOUR PLAYERS EFFORTS.**
- **YOUR OFFENSIVE LINEMEN MUST BE ABLE TO APPLY THEIR BLOCKING RULES AGAINST ANY FRONT THEY ENCOUNTER AND BLOCK THEM FROM THE SNAP TO THE ECHO OF THE WHISTLE.**
- **DOWN FIELD BLOCKING MUST BE AGGRESSIVE AND PHYSICAL.**
- **YOUR QUARTERBACK IS THE HUB OF YOUR OFFENSE AND HIS MECHANICS MUST BE DRILLED TO PERFECTION.**
- **YOU MUST HAVE BACKFIELD FAKES TO THE EXTREME (20 YARDS DOWN FIELD). THIS WILL KEEP TEAMS FROM GANG TACKLING.**
- **OUT REPETITION THE DEFENSE.**
- **PUT TWO-GAP PRESSURE ON DEFENDERS BY ATTACKING FROM INSIDE OUT.**



IF YOU ARE GOING TO RUN THIS OFFENSE II:

- **RUN AS MANY SIMILAR BLOCKING SCHEMES AS CONCEPTUALLY POSSIBLE. DO A FEW THINGS WELL.**
- **TEACH KIDS TO APPLY RULES VS. MULTIPLE FRONTS.**
- **KEEP THINGS SIMPLE AND CONSISTENT.**
- **UTILIZE GREAT TEACHING.**
- **BLOCK FROM THE SNAP TO THE ECHO OF THE WHISTLE.**
- **KEEP TEAMS FROM GANG-TACKLING BY HIDING THE BALL AND CARRYING OUT GREAT FAKES FOR AT LEAST 20 YARDS.**
- **ALLOW YOUR BACKS TO ATTACK EACH HOLE.**
- **MAKE BIG PLAYS WHEN THROWING THE BALL.**
- **REMOVE DOUBT FROM YOUR KIDS MINDS BY GETTING THEM TO BE AGGRESSIVE, NASTY AND RELENTLESS.**

OFFENSIVE LINE ALIGNMENT

- **ALL LINEMEN WILL ASSUME A TWO-POINT STANCE WHEN REACHING THE LINE OF SCRIMMAGE. THE CENTER SHOULD BE READY TO SNAP THE BALL. WE WANT OUR LINEMEN OFF THE BALL AS FAR AS LEGALLY POSSIBLE. BOTH GUARDS SHOULD ALIGN THEIR FEET IN A POSITION WHERE THE TOPS OF THEIR HELMETS WILL INTERSECT THE BELT OF THE CENTER WHEN THEY ARE IN A THREE POINT STANCE. THE TACKLES AND ENDS WILL ALIGN THEIR DOWN HANDS EVEN WITH THE GUARD'S DOWN HAND RATHER THAN ALIGNING THEIR FEET. THIS WILL CREATE A STRAIGHT OFFENSIVE LINE THAT IS OFF THE BALL AS FAR AS LEGALLY POSSIBLE.**

OFFENSIVE LINE SPLITS

- **FROM TACKLE TO TACKLE THE LINE SPLITS WILL BE 6 INCHES. THEY MAY BE EXTENDED UP TO 3 FEET. THE NORMAL SPLIT FOR THE TIGHTS END IS 3 FEET. THIS MAY BE EXTENDED UP TO 5 FEET.**



IDENTIFYING THE DEFENSE

- **AFTER THE LINEMEN ARE ALIGNED AT THE LINE OF SCRIMMAGE, THE CENTER BEGINS TO IDENTIFY THE DEFENSIVE FRONT. HE WILL CALL OUT EITHER “ODD – EVEN – GUARDS COVERED – OR GAP 8” BASED UPON THE DEFENSIVE ALIGNMENT. AFTER THIS HE WILL POINT TO THE 1ST MAN OUTSIDE OF THE CENTER ON BOTH SIDES SO THE GUARDS WILL KNOW WHO THEIR BASE RULE IS. THE GUARDS WILL POINT TO AND IDENTIFY THE 1ST AND 2ND DEFENDERS OUTSIDE THE CENTER FOR THE TACKLES. THE TACKLES WILL THEN POINT TO AND IDENTIFY THE 2ND AND 3RD DEFENDERS OUTSIDE THE CENTER FOR THE TIGHT ENDS. ADJUSTMENTS AND CO-OPS COULD BE CALLED AT THIS TIME OR ANY TIME BEFORE THE BALL IS SNAPPED.**

6 COMMANDMENTS OF OFFENSIVE LINE PLAY:

- **NON-STOP BLOCKING FROM THE SNAP TO THE ECHO OF THE WHISTLE.**
- **GREAT FUNDAMENTALS.**
- **FIRST LEVEL (LOS) BLOCK EVERY FRONT UNDER THE SUN.**
- **SECOND LEVEL (DOWN FIELD) PHYSICAL BLOCKING WITH GREAT EFFORT.**
- **BLOCK AGGRESSIVELY ON PASS PLAYS.**
- **ACCEPT REPETITION WITH ENTHUSIASM. WE MUST LEARN EVERY DAY!**

TERMINOLOGY:

- **ARC:** DONE BY A BACKSIDE TACKLE. STEPS TO THE NEAR HIP OF THE MAN THE CENTER IS BLOCKING TO FILL FOR A PULLING GUARD. IF NO DEFENDER SHOWS, HUNT.
- **CO-OP:** TWO OFFENSIVE LINEMEN COOPERATIVELY BLOCK A DEFENSIVE STACK BY STEPPING WITH ADJACENT FEET AT THE CROTCH OF THE DOWN DEFENDER WITH THEIR EYES TO THE LINEBACKER. EACH LINEMEN IS RESPONSIBLE FOR THE DEFENDER THAT COMES TO THEIR INSIDE GAP.
- **DOWN:** STEP WITH A FLAT DOWN STEP AND BLOCK THE FIRST MAN INSIDE.
- **GAP:** BLOCK THE FIRST MAN ON THE LINE OF SCRIMMAGE TO THE INSIDE GAP.

TERMINOLOGY CONTINUED:

- **GUT:** LINEMAN DROP STEPS AND PULLS AROUND THE ADJACENT LINEMAN TO THE NEXT GAP. TURN UP FIELD AND BLOCK THE FIRST DEFENDER OFF THE LINE OF SCRIMMAGE (USUALLY A LINEBACKER.) SIMILAR FOOTWORK TO SHORT TRAP.
- **HOOK:** ATTACK THE OUTSIDE NUMBER OF A DEFENDER WITH YOUR HEAD AND SEAL HIM INSIDE.
- **INFLUENCE:** WHEN PATH IS COVERED, TAKE A DROP STEP WITH INSIDE FOOT, ALLOWING THE ADJACENT OFFENSIVE LINEMAN TO YOUR OUTSIDE CROSS YOUR FACE. THEN YOU MUST ATTACK THE NEXT UGLY SHIRT TO YOUR OUTSIDE.
- **REACH:** BLOCK THE DEFENDER ALIGNED IN THE OUTSIDE GAP. STEP WITH OUTSIDE FOOT AT THE OUTSIDE NUMBER OF THE DEFENDER AND HOOK HIM IN.

TERMINOLOGY CONTINUED:

- **SINGLE:** THIS IS A ONE ON ONE BLOCK FOR AN OFFENSIVE LINEMAN ON A DEFENSIVE LINEMAN. THIS CALL IS MADE WHEN AN OFFENSIVE LINEMAN BELIEVES HE CAN HANDLE A DEFENDER ALONE WITHOUT A DOUBLE TEAM. IT WILL FREE UP THE OTHER LINEMAN TO GO ON TO ANOTHER DEFENDER.
- **SWITCH:** EXCHANGING BLOCKING RESPONSIBILITIES WITH THE OFFENSIVE LINEMAN ADJACENT TO YOU. USUALLY IF YOUR PATH TO THE FIRST LINEBACKER INSIDE IS COVERED BY A MAN IN YOUR INSIDE GAP.
- **TAILGATE:** STEP FIRST WITH INSIDE FOOT TO GAP. IF NO DEFENDER SHOWS, TAKE A DROP STEP WITH OUTSIDE FOOT AND OPEN OUTSIDE, LOOKING FOR A DEFENDER PURSUING BACKSIDE. IF NONE, HUNT.



TERMINOLOGY CONTINUED:

- **11 X 1 RULE:** THERE ARE ELEVEN OF THEM AND ONE OF YOU. YOU BETTER HIT SOMEBODY!!!
- **10 STEP RULE:** YOU MUST SUSTAIN YOUR BLOCKS FOR TEN STEPS. BLOCKING IS A TEN STEP PROCESS!
- **6 SECOND RULE:** THE AVERAGE FOOTBALL PLAY LASTS FOR 6 SECONDS. YOU MUST BLOCK FROM THE SNAP TO THE ECHO OF THE WHISTLE.
- **OFF AND SOFT:** A LINEBACKER WHO IS OFF THE BALL AND NOT THREATENING TO STUNT.
- **HARD ON:** A LINEBACKER WHO IS UP AND THREATENING WITH A STUNT AT THE LINE OF SCRIMMAGE.

TERMINOLOGY CONTINUED:

- **“GUTS”:** SWITCH ASSIGNMENT CALL FOR GUARDS & TACKLES.
- **“TEXAS”:** SWITCH ASSIGNMENT CALL FOR TACKLES & ENDS.
- **“TRADE”:** SWITCH ASSIGNMENT CALL FOR ENDS & HALF BACKS.
- **“POUND”:** A CALL FROM THE CENTER TO THE BACKSIDE TACKLE LETTING HIM KNOW THAT HE IS GOING TO PUCH A 3 TECHNIQUE TO THE BACKSIDE SO THE TACKLE CAN ARC ON HIM. THEN THE CENTER WILL CUT-OFF A BACKSIDE LINEBACKER.
- **“LAKE”:** DROP BACK PASS PROTECTION WHERE A RB WILL BLOCK THE END MAN ON THE LEFT SIDE OF THE DEFENSIVE LINE. LINEMEN WILL BLOCK BACK TO THE RIGHT.
- **“RIVER”:** DROP BACK PASS PROTECTION WHERE A RB WILL BLOCK THE END MAN ON THE RIGHT SIDE OF THE DEFENSIVE LINE. LINEMEN WILL BLOCK BACK TO THE LEFT.

BACKFIELD ALIGNMENT

- **THE WING-T QB WILL LIGN UP UNDER THE CENTER WITH HIS FEET NO MORE THAN SHOULDER WIDTH APART. HIS KNEES WILL BE SLIGHTLY FLEXED AND HIS BACK STRAIGHT. THIS WILL ALLOW HIM TO MAKE A GOOD REVERSE PIVOT WITHOUT TANGLING HIS FEET UP.**
- **THE FULLBACK WILL LINE UP DIRECTLY BEHIND THE BALL WITH HIS HEELS AT FOUR AND ONE HALF YARDS FROM THE FRONT TIP OF THE FOOTBALL.**
- **THE HALFBACKS LINE UP IN A STRAIGHT LINE WITH THE FULLBACK BASED ON A SIX-FOOT WINGSPAN. ALL THREE BACKS ARE POSITIONED CLOSE ENOUGH TO THE FORMATION TO BE USED AS BLOCKERS, BALL CARRIERS, AND DECOYS FOR MISDIRECTION.**

NUMBERING BACKS & ENDS

9 END

C

8 END

1 BACK

3 BACK

4 BACK

2 BACK



CADENCE

- **OUR NORMAL SNAP COUNT IS “DOWN, READY-SET, HUT ONE, HUT TWO, HUT THREE, GO!, HIT!” THE BALL WILL BE SNAPPED ON A PRE-DETERMINED COUNT CALLED AFTER “READY-SET”. THE QB’S MUST PRACTICE THIS IN A GROUP “CHOIR PRACTICE”. WE WANT THE SNAP COUNT TO BE A “SING SONG”, RYTHMIC COUNT.**

CALLING A PLAY

- **THE PLAYS WILL BE CALLED WITH A THREE DIGIT NUMBER. THERE MAY BE A WORD THAT FOLLOWS THAT NUMBER TO IDENTIFY THE PLAY.**
- **THE FIRST DIGIT WILL BE THE FORMATION USED.**
- **THE SECOND DIGIT WILL BE FOR THE BALL CARRIER OR ACTION BEING USED.**
- **THE THIRD DIGIT WILL BE FOR THE HOLE BEING ATTACKED.**
- **FOR EXAMPLE: 238 SWEEP IS WING RIGHT WITH THE 3 BACK CARRYING THE BALL AT THE 8 HOLE ON A SWEEP ACTION.**



“0” FORMATION

FULL HOUSE-T

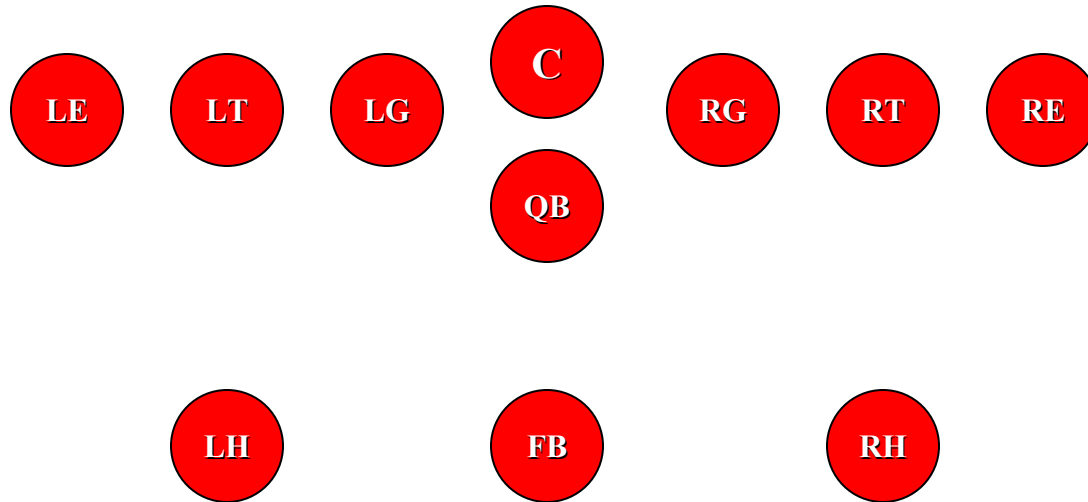



“100” FORMATION

DOUBLE WING

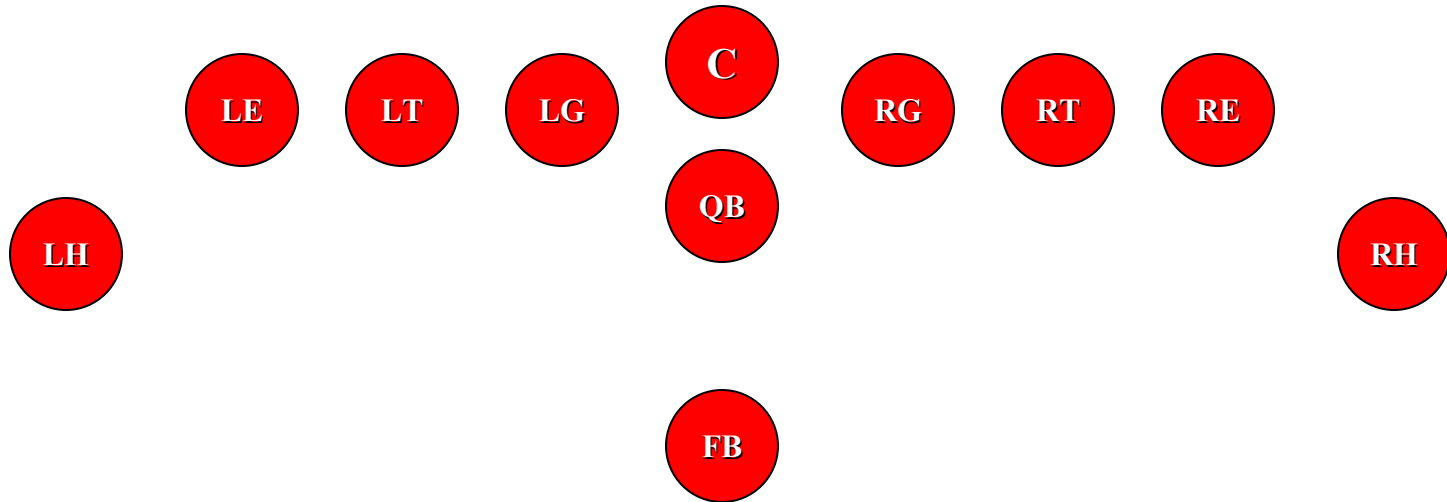



“200” FORMATION

WING RIGHT

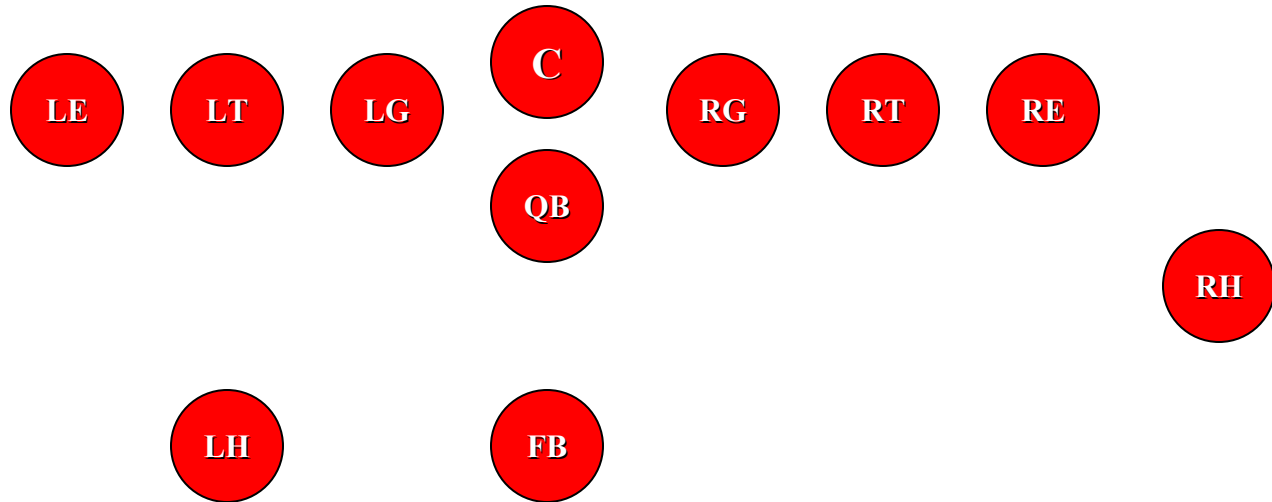



“300” FORMATION

WING LEFT

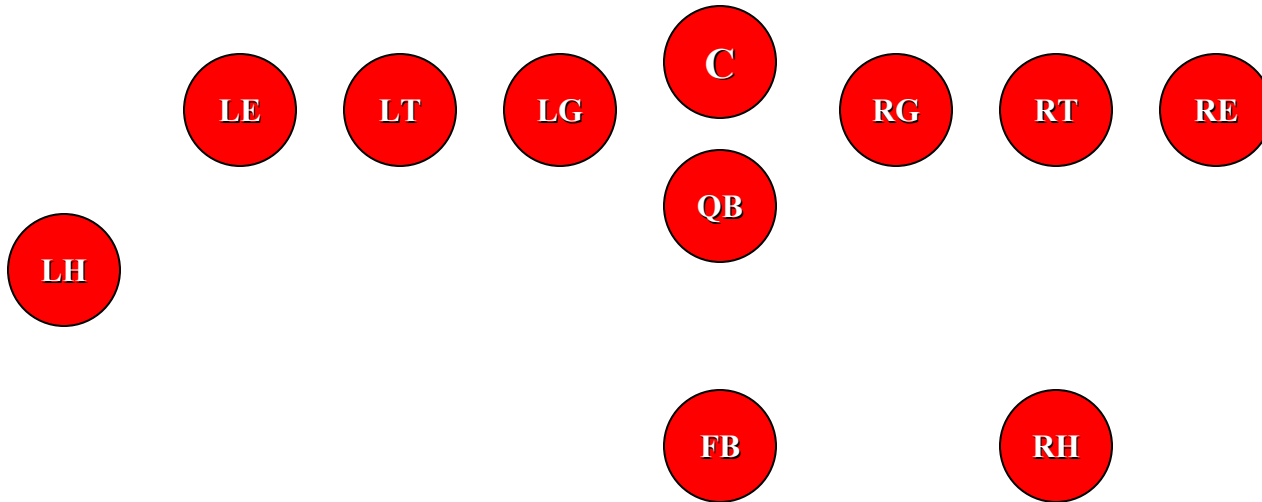

“400” FORMATION

POWER PRO RIGHT

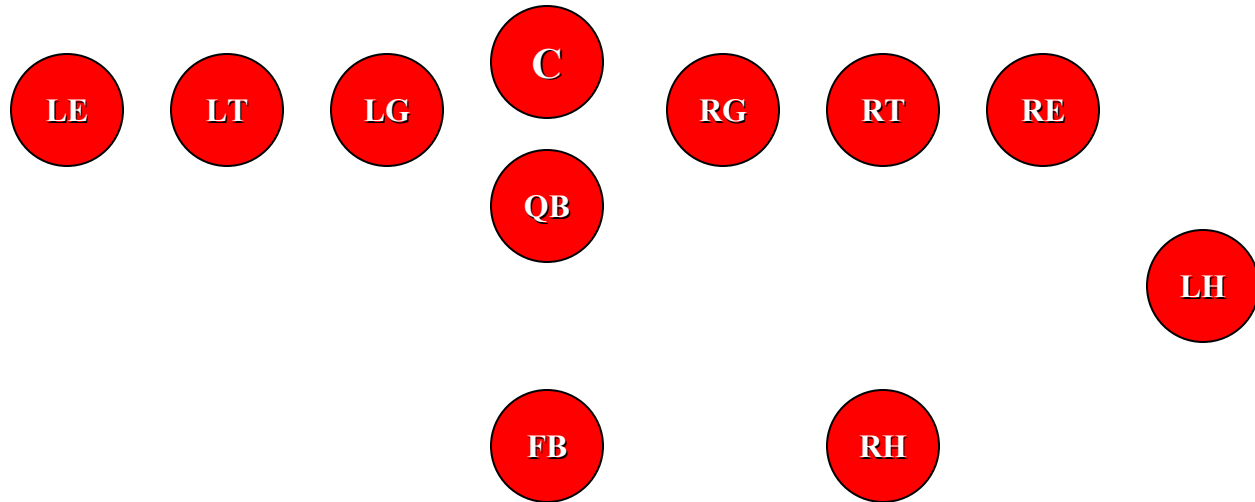

“500” FORMATION

POWER PRO LEFT

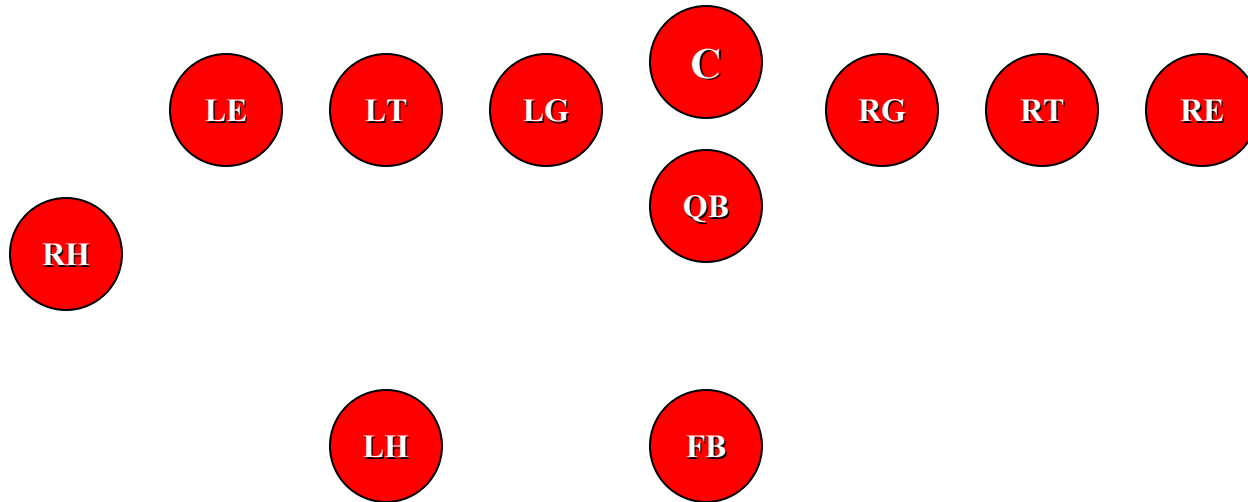

“600” FORMATION

SPREAD RIGHT

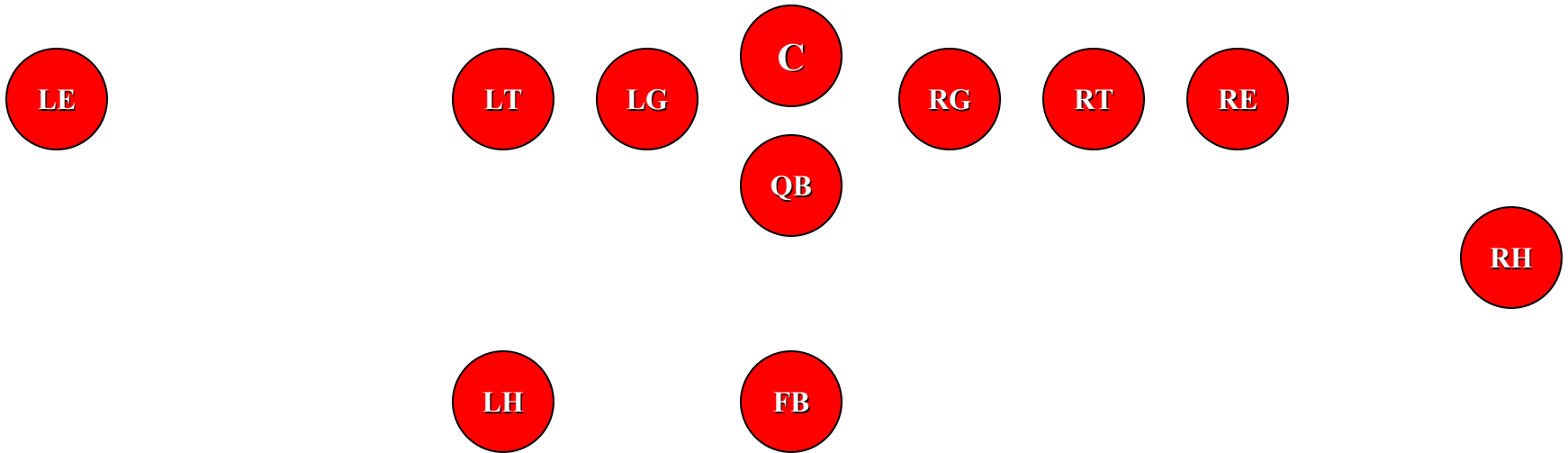

“700” FORMATION

SPREAD LEFT

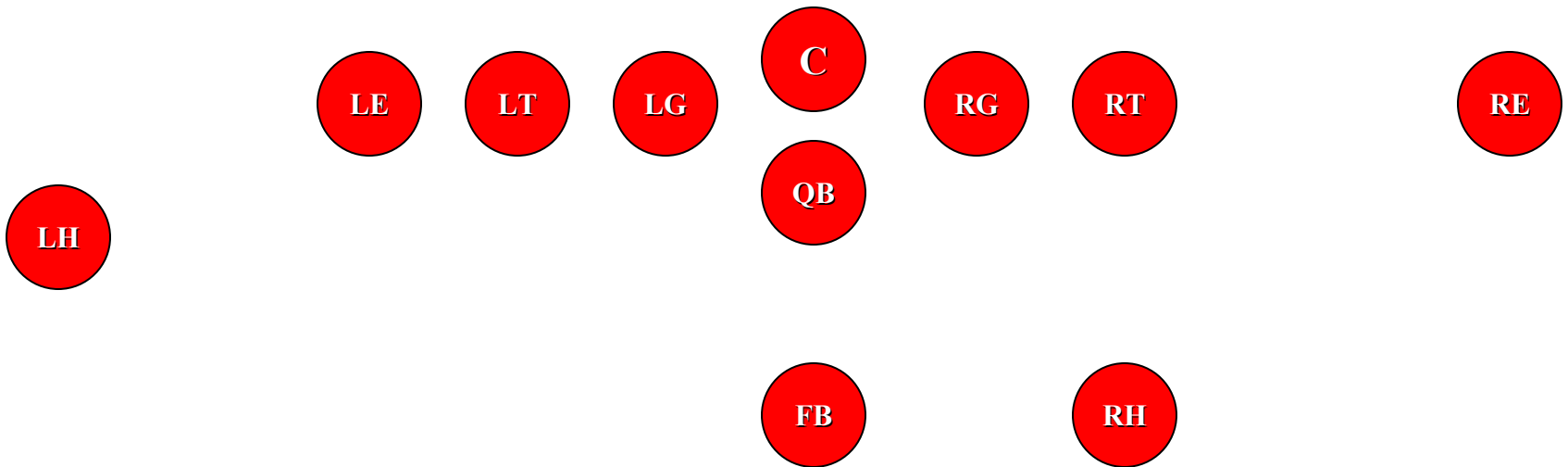

“800” FORMATION

POWER SPREAD RIGHT

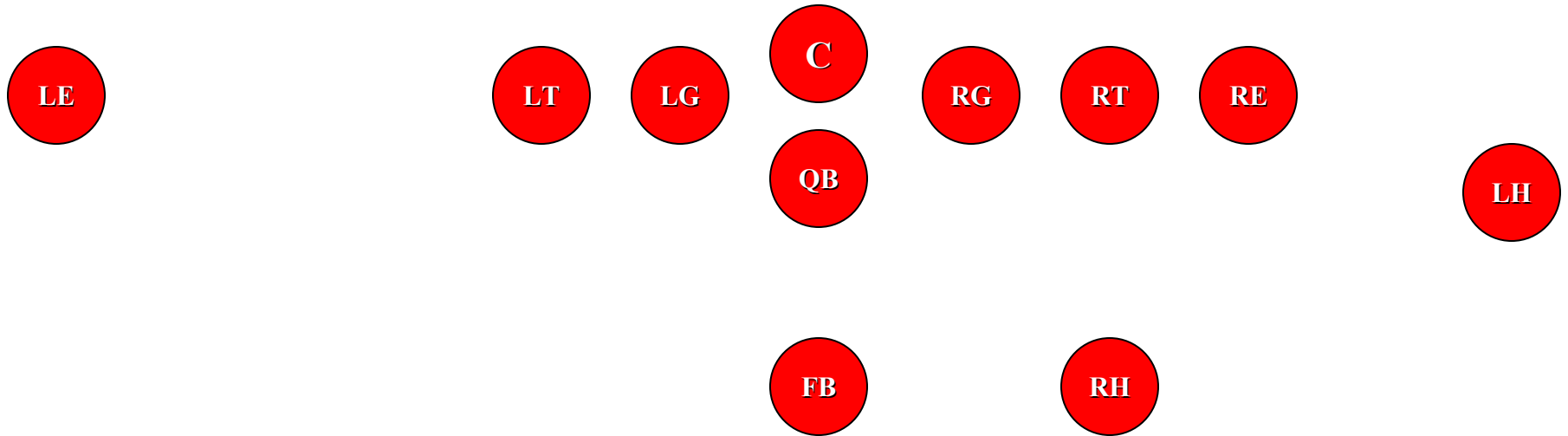

“900” FORMATION

POWER SPREAD LEFT

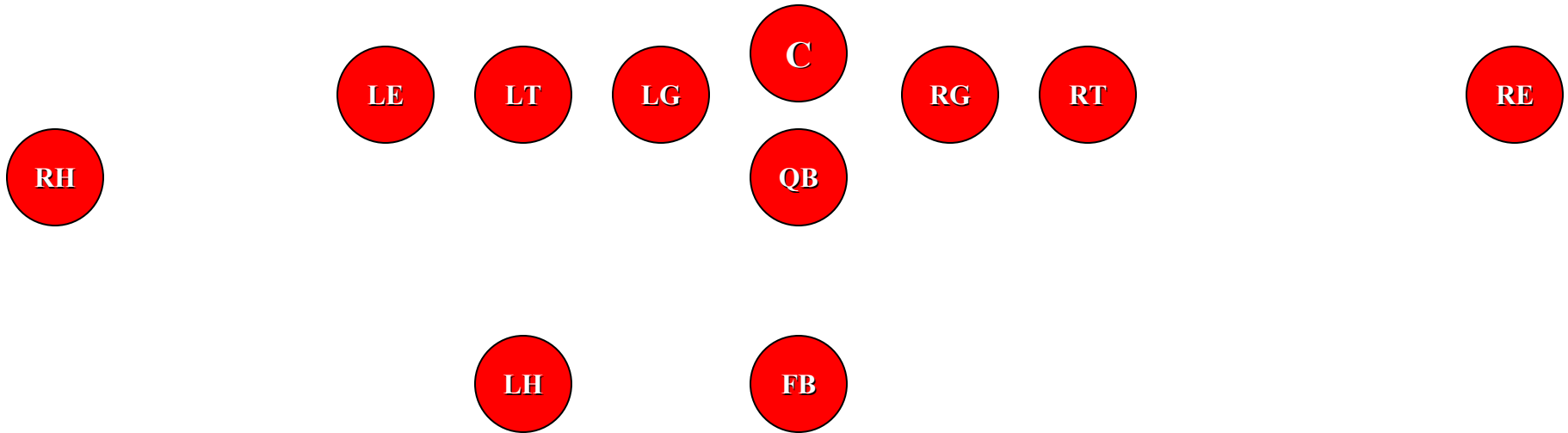



NUMBERING THE HOLES

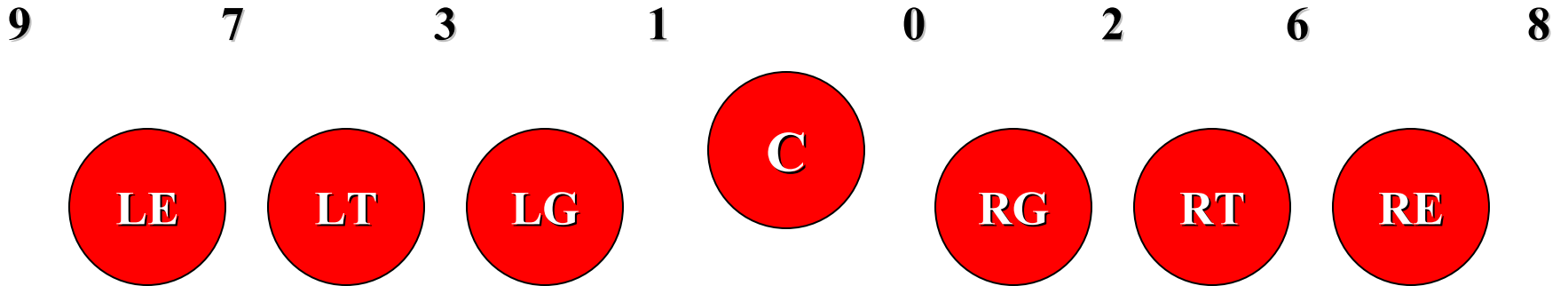

THE GAPS

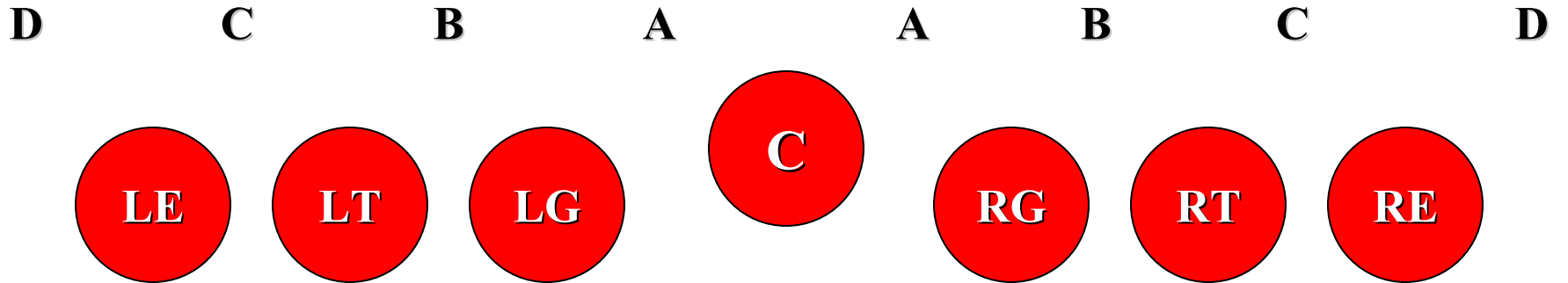

NUMBERING DEFENSIVE LINEMEN TECHNIQUES

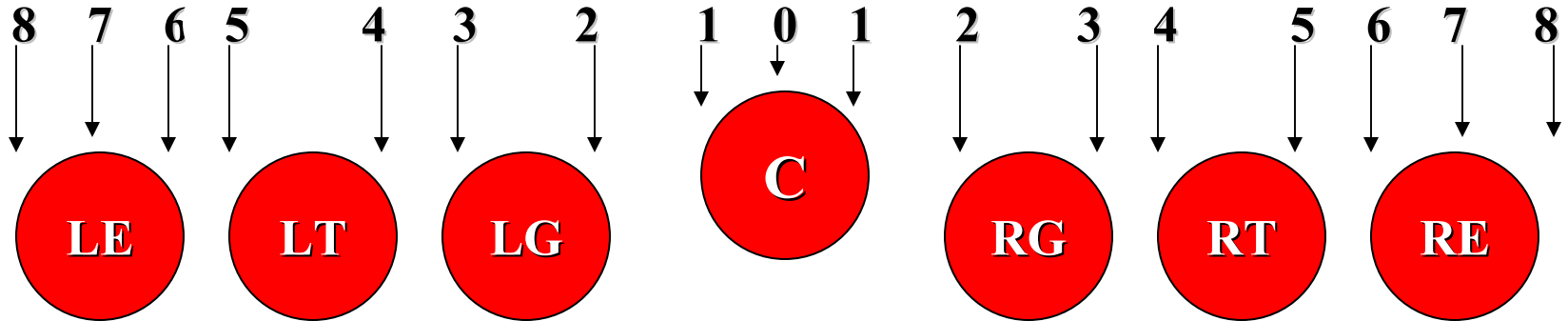

NUMBERING DEFENDERS FROM THE CENTER OUT

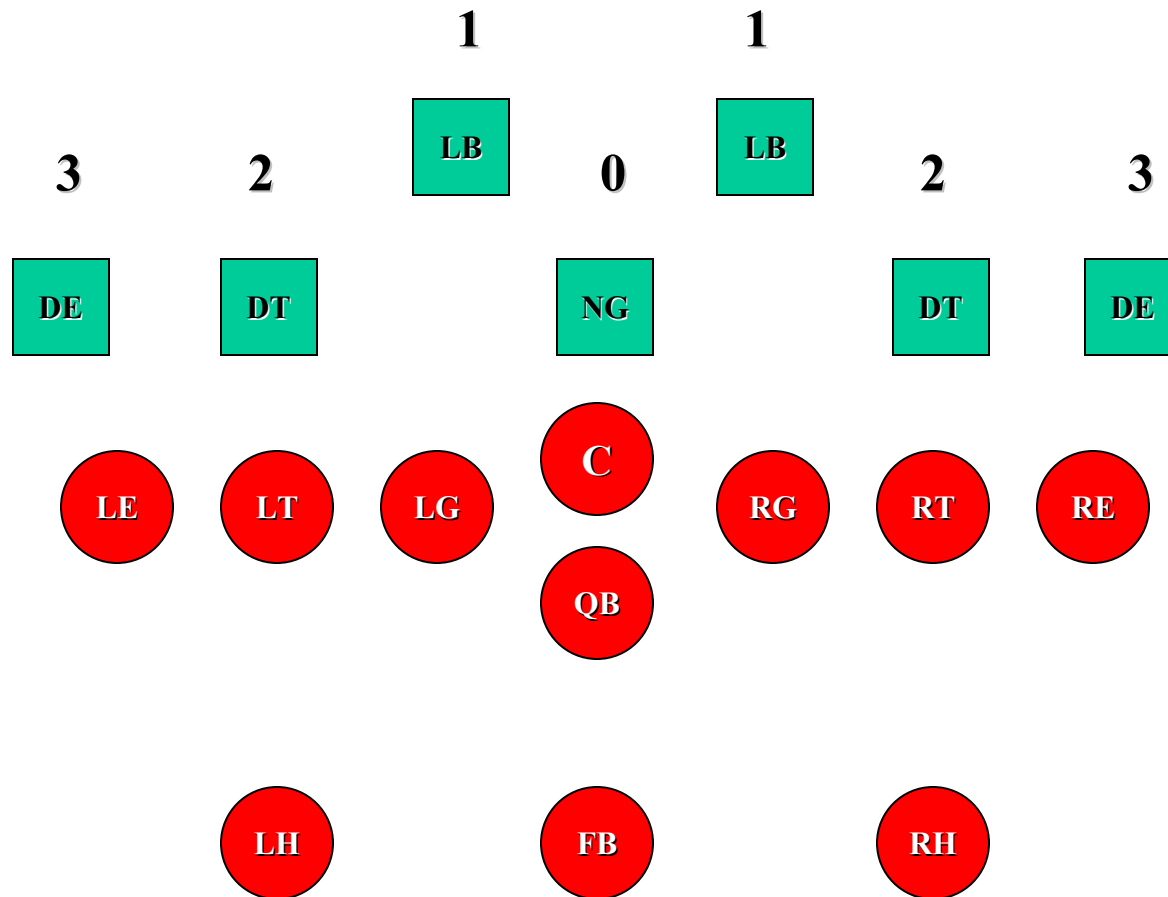

NUMBERING STACK

DEFENDERS

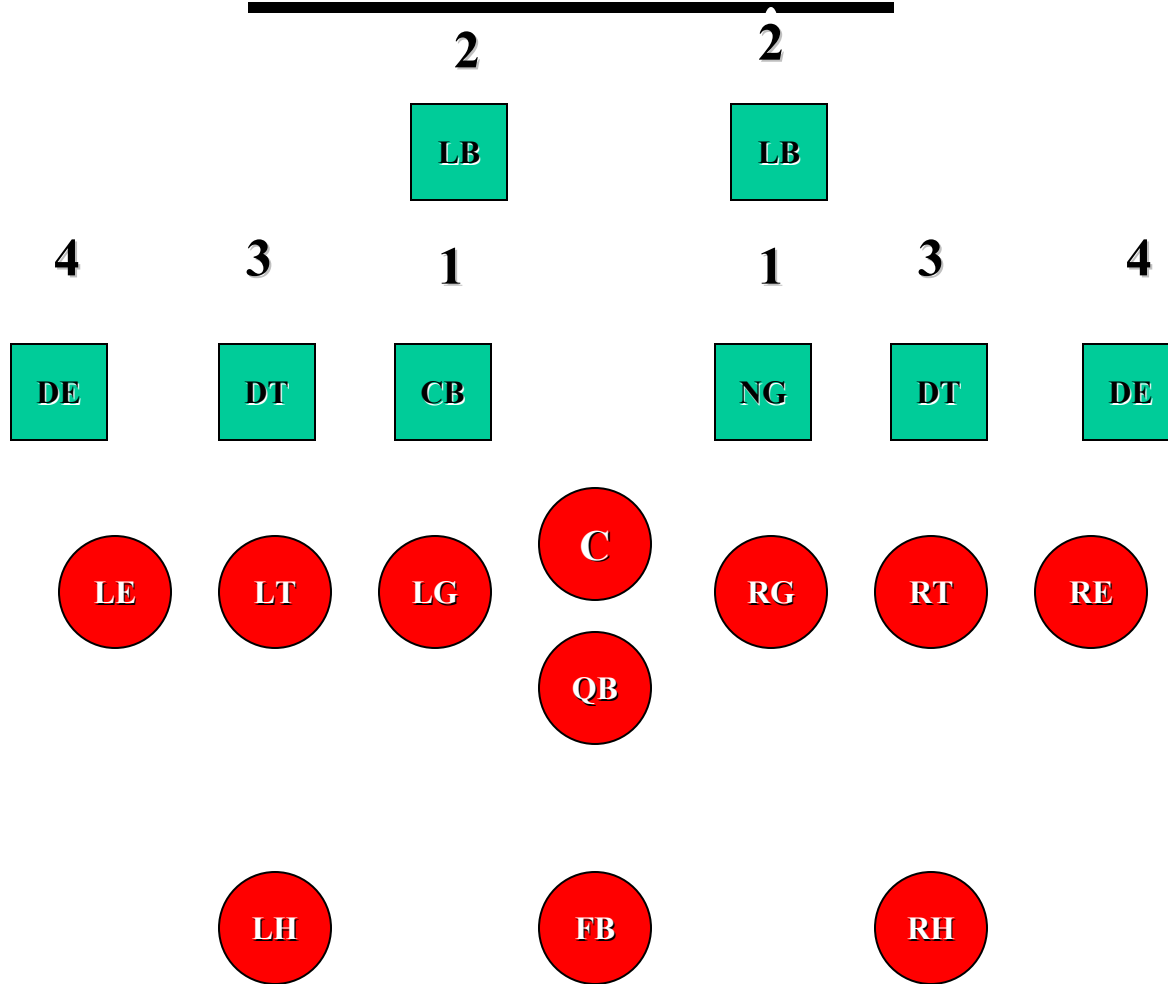



BASE BLOCKING RULES:

- **C: BLOCKS ZERO (MAN ON).**
- **G: BLOCK 1ST MAN OUTSIDE CENTER.**
- **T: BLOCK 2ND MAN OUTSIDE CENTER.**
- **TE: BLOCKS 3RD MAN OUTSIDE CENTER**

STACK RULES:

- **0-1 STACK: CENTER & GUARD CO-OP.**
- **1-2 STACK: GUARD & TACKLE CO-OP.**
- **2-3 STACK: TACKLE & END CO-OP.**
- **3-4 STACK: END & BACK CO-OP.**

“0” VS. 5-2 DEFENSE

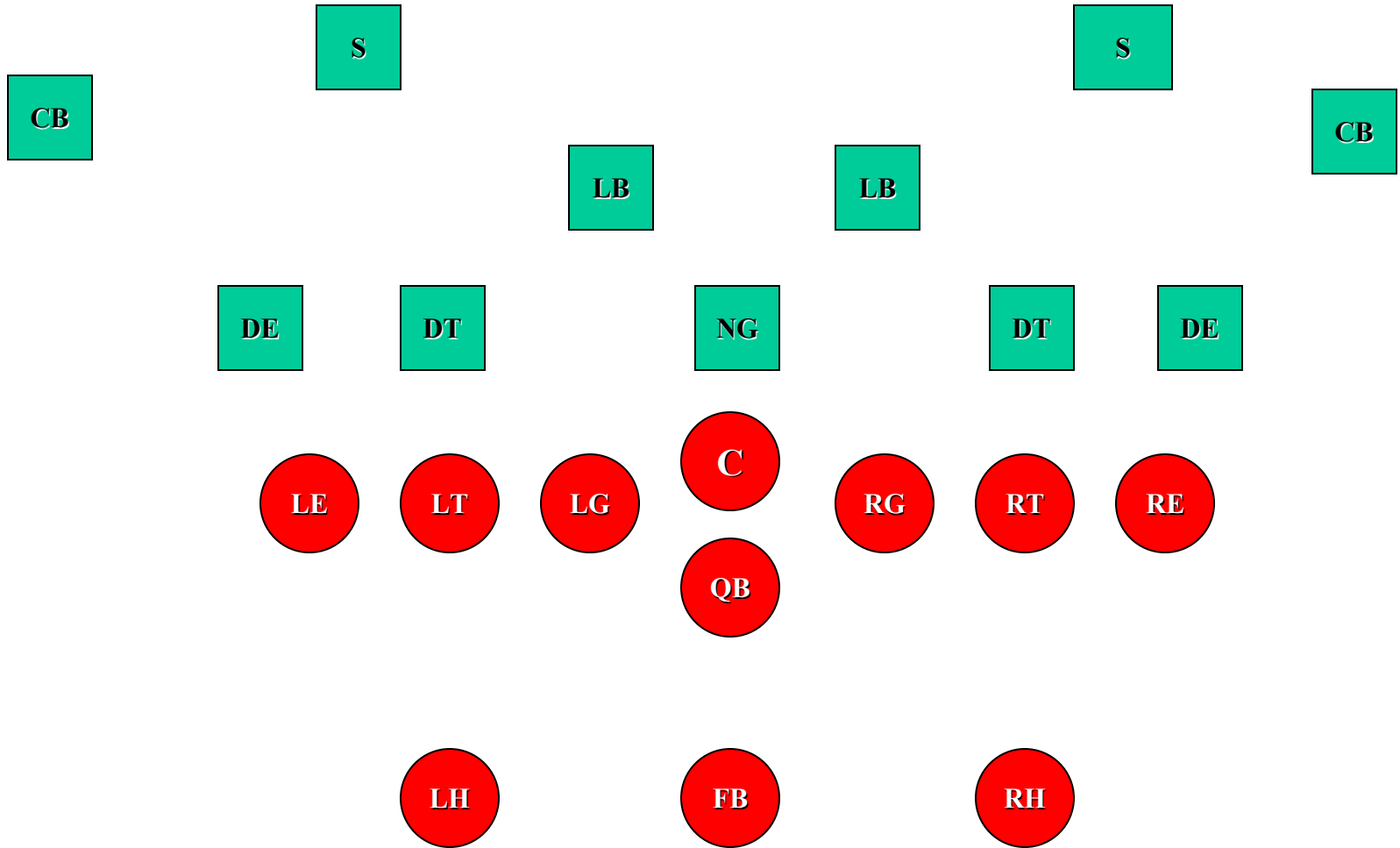

“0” VS 5-3 DEFENSE

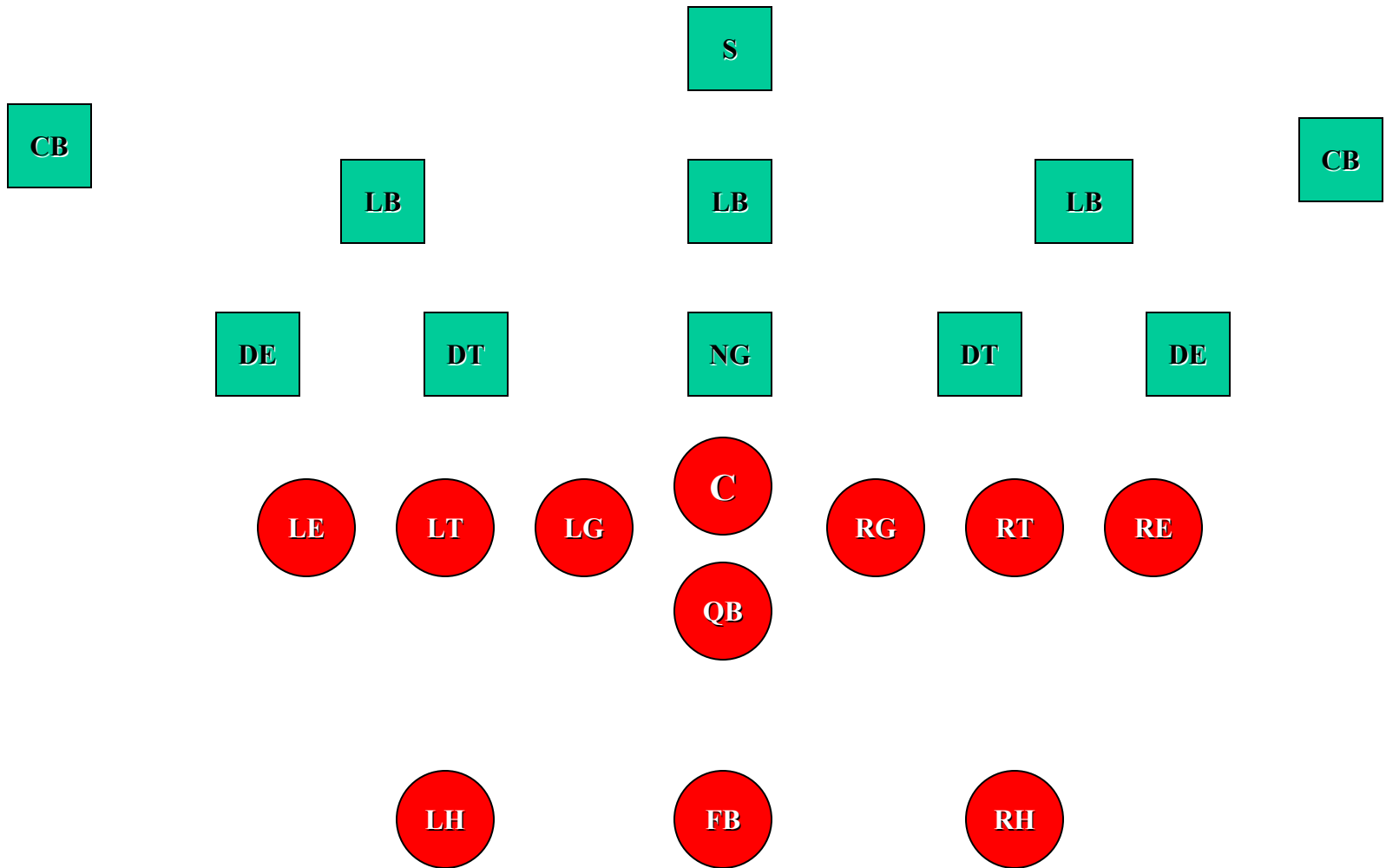

“0” VS 7-1 DEFENSE

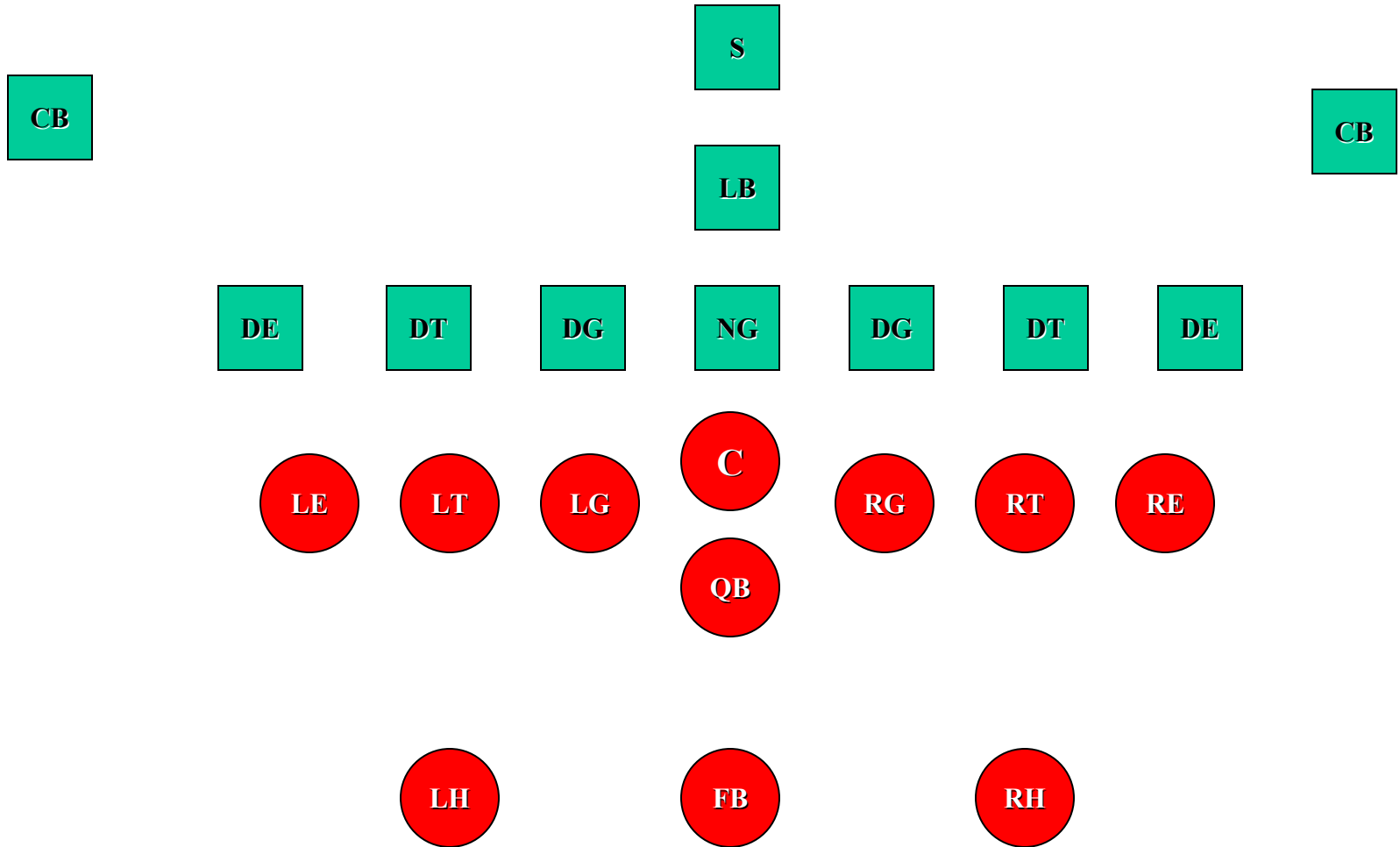

“0” VS. 6-1 DEFENSE

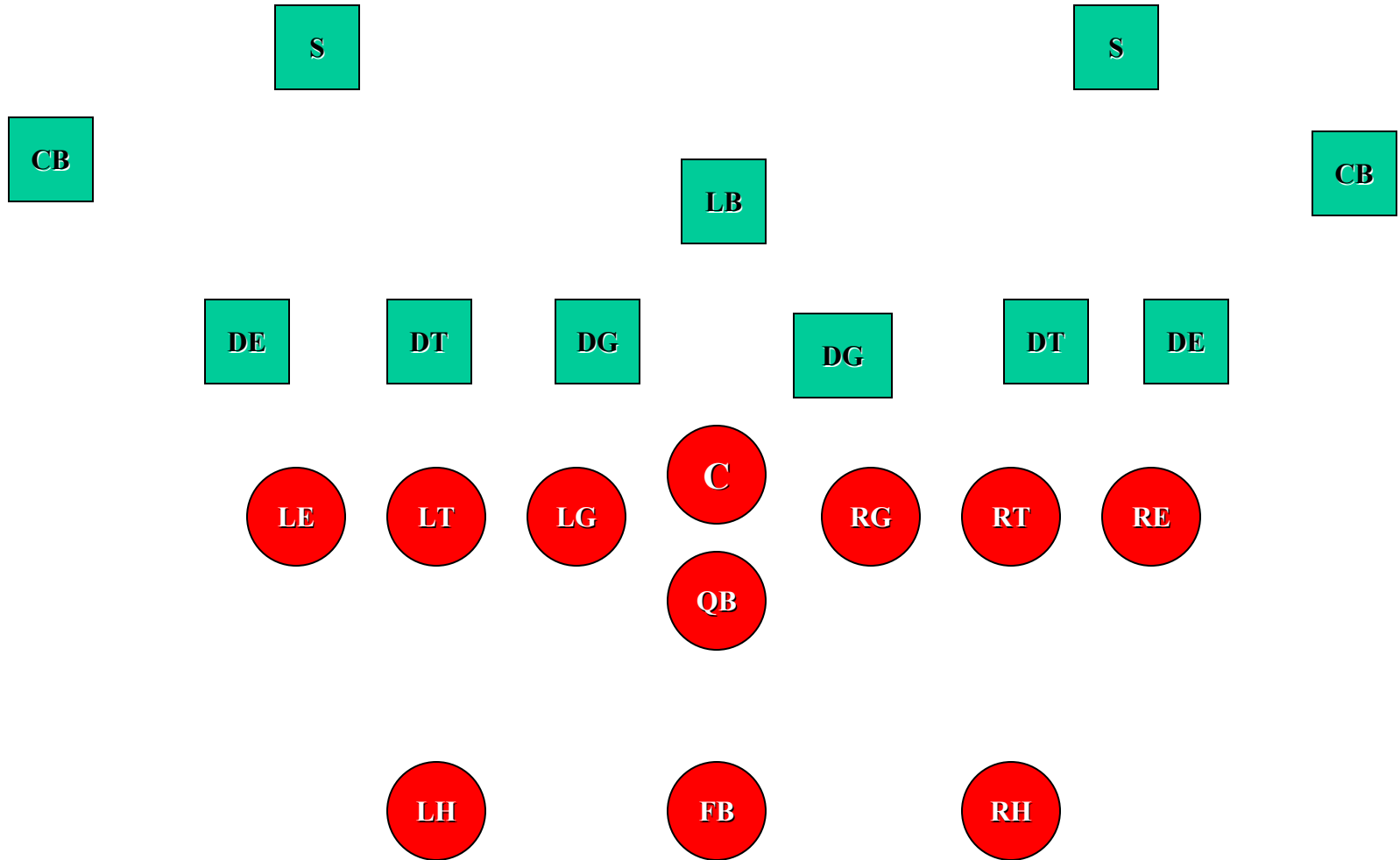

“0” VS. 6-2 DEFENSE

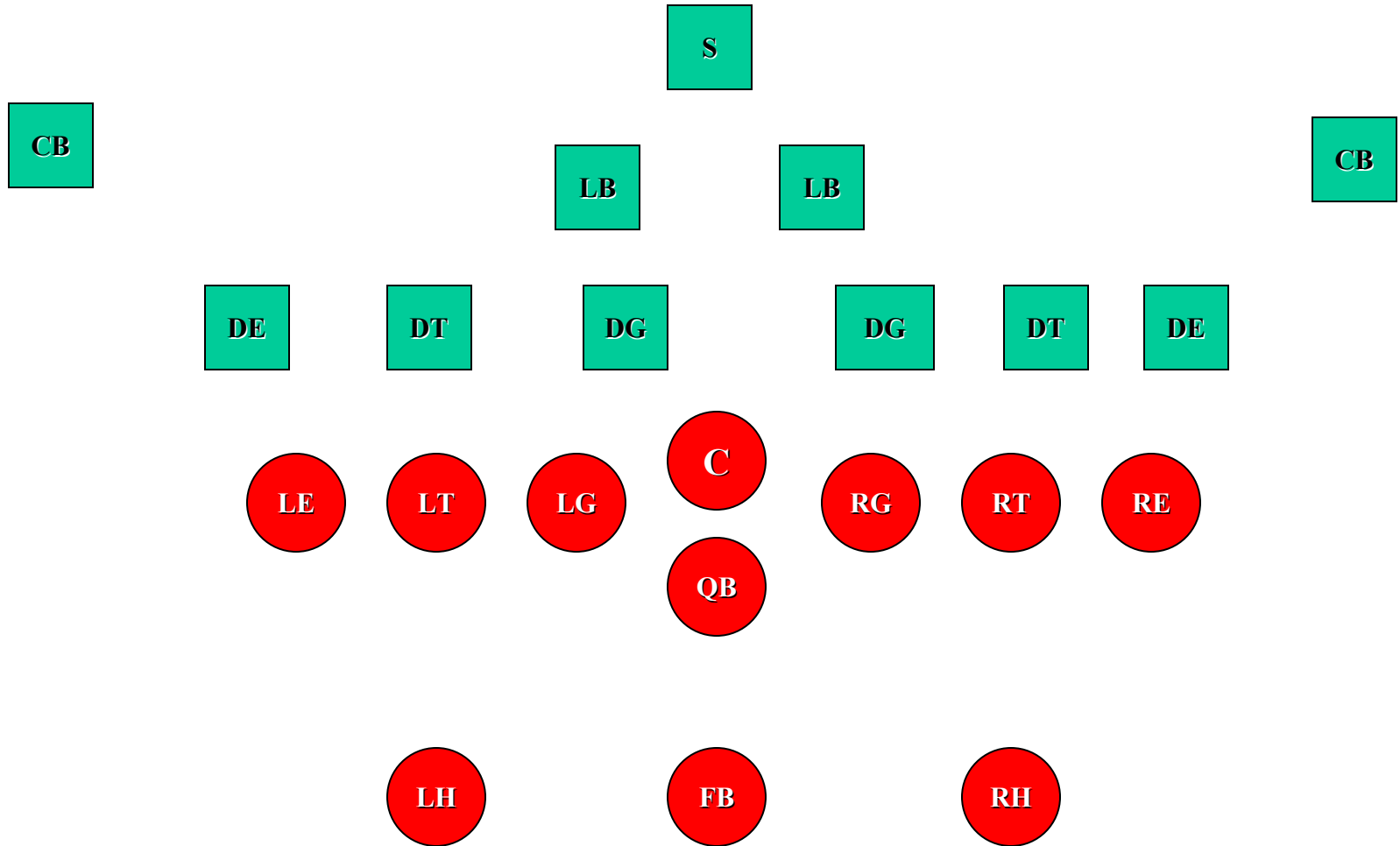

“0” VS. 6-5 DEFENSE

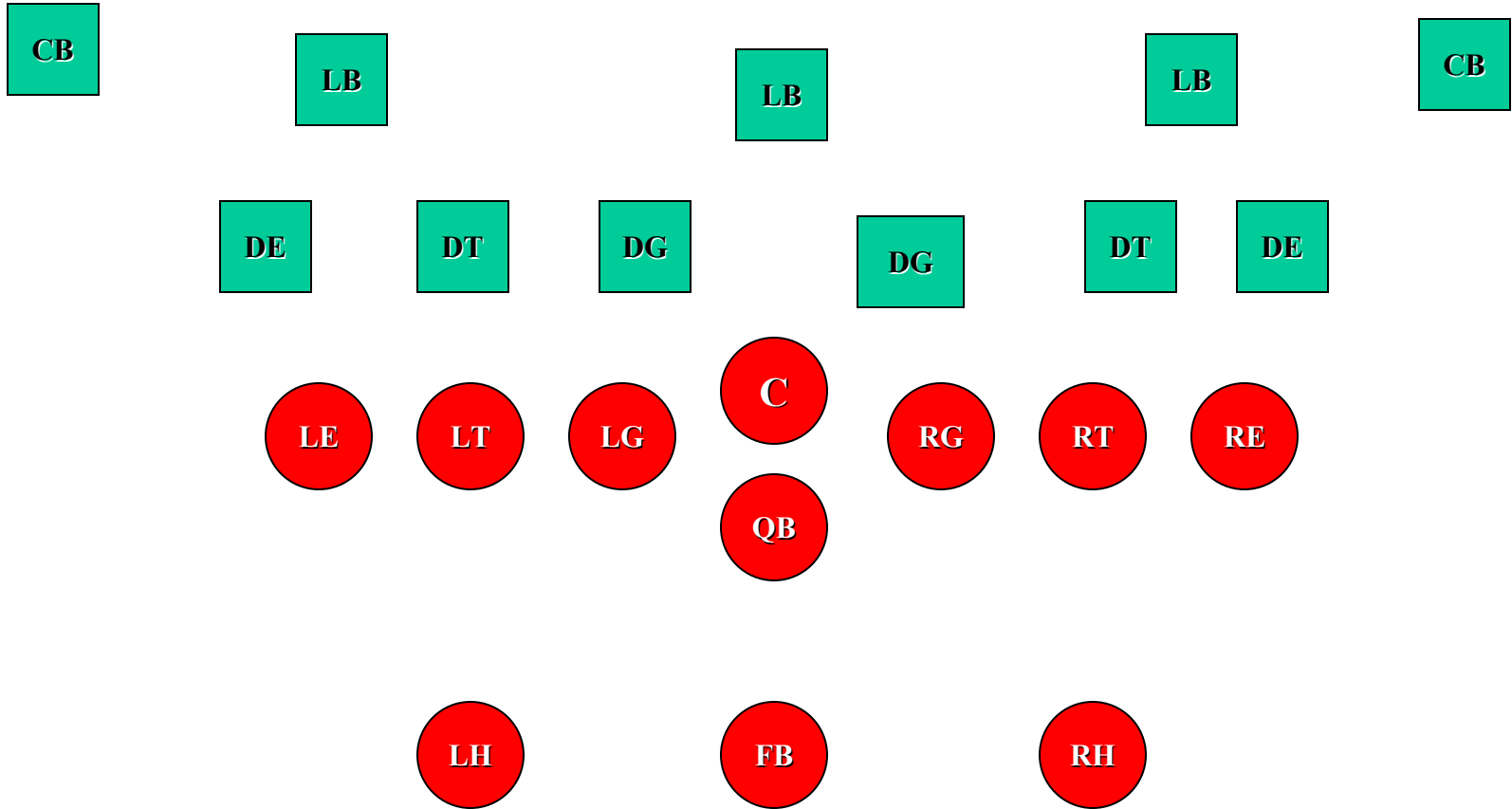

“0” VS. 4-3 DEFENSE

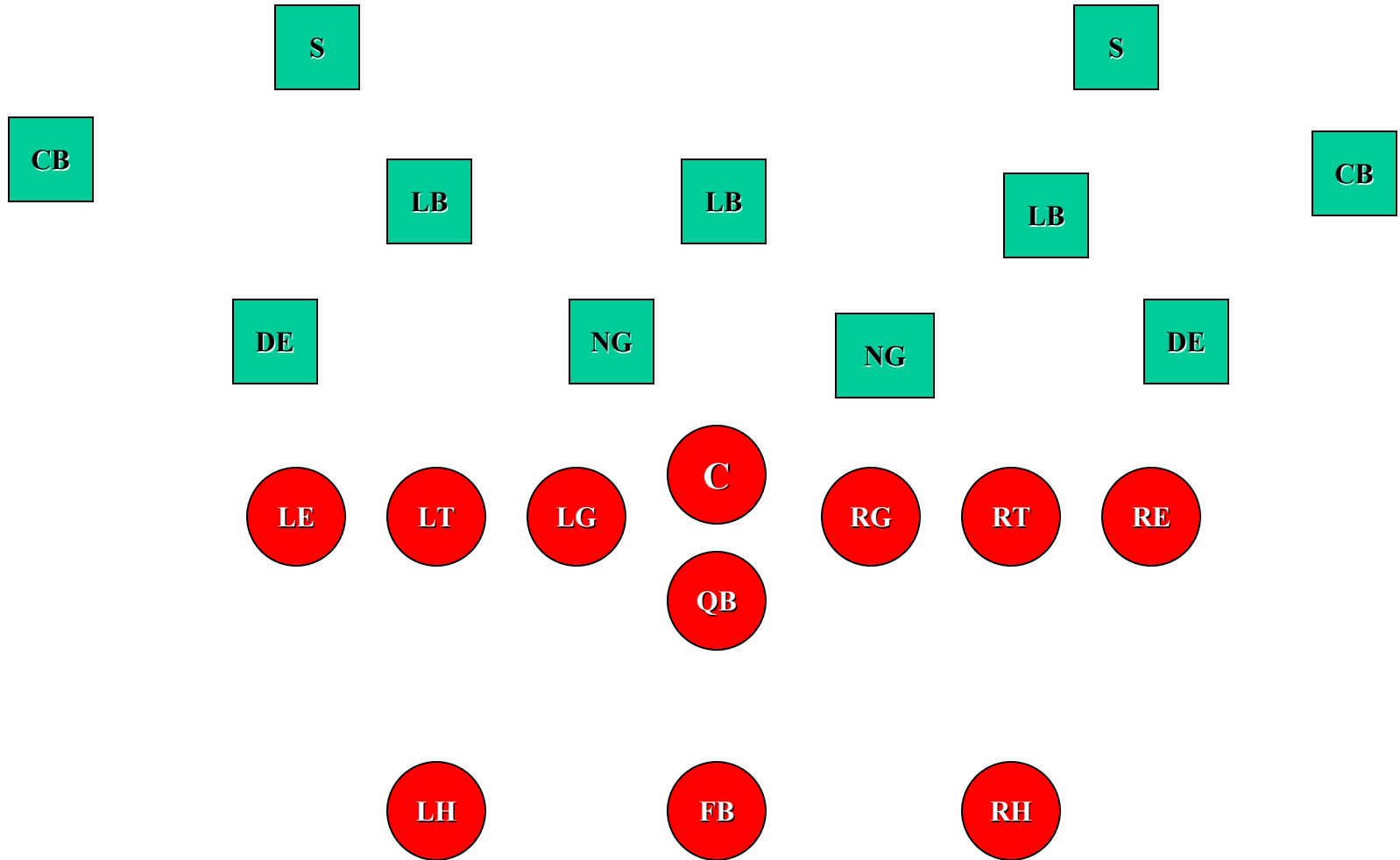

“0” VS. 4-4 DEFENSE

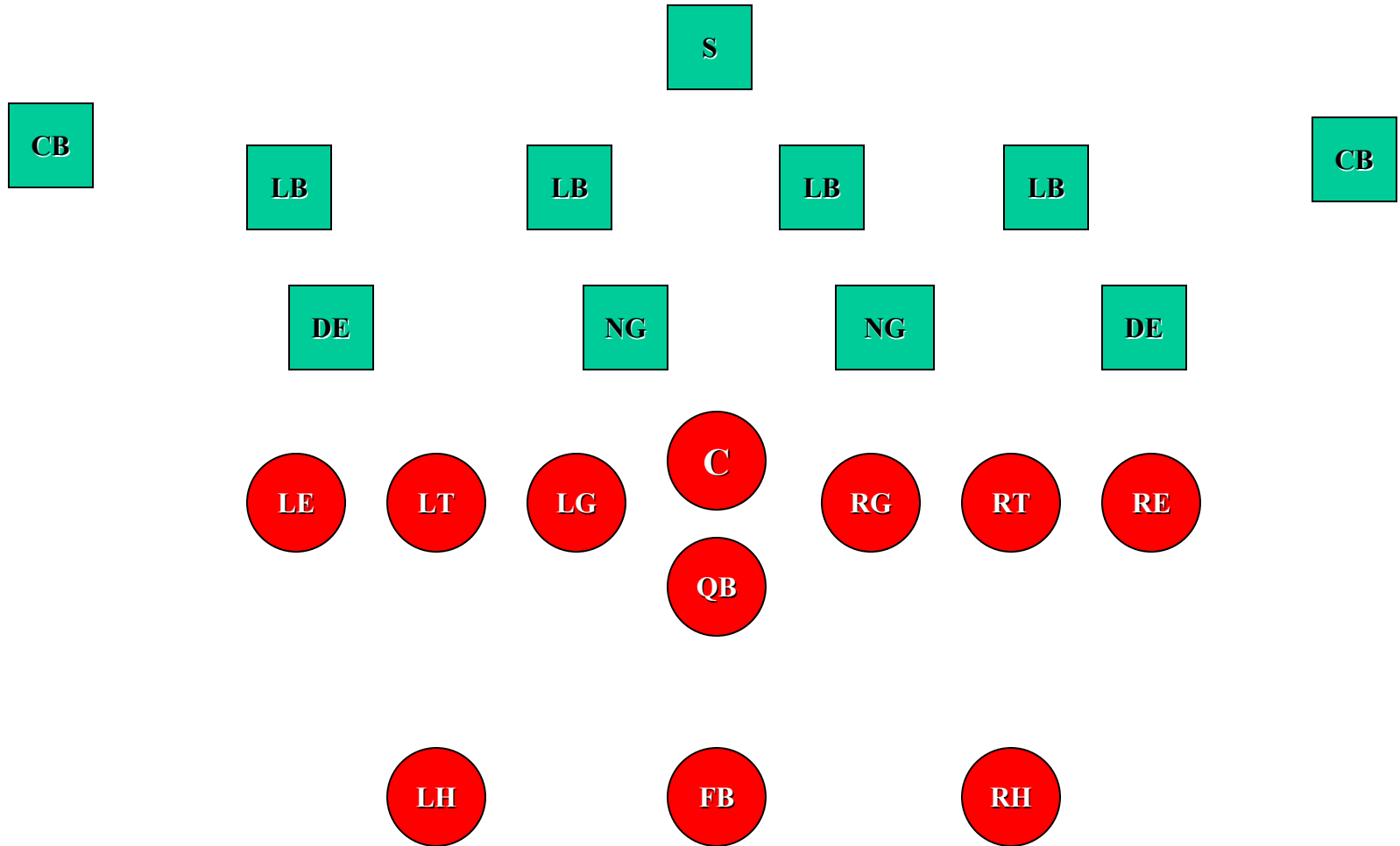

THE WING-T RUN PLAYS

- RUN PLAYS
- 40-41 TRAP
- 40-41 STAR
- 42-43 TRAP
- 42-43 ISO
- 36-27 OFF-TACKLE
- 36-27 POWER
- 36-27 KEEP OUT
- 36-27 REVERSE
- 36-27 REVERSE SOLID
- 38-29 SWEEP
- 38-29 POWER SWEEP
- 38-29 HALF REVERSE

40 - 41 TRAP RULES

TE:

FSE: BLOCK THE DEFENDER IN THE MIDDLE THIRD OR HALF OF THE FIELD.

BSE: BLOCK THE DEFENDER IN THE MIDDLE THIRD OR HALF OF THE FIELD.

T:

FST: BUILD A WALL WITH THE FSG AND LOOK FOR THE 1ST LB INSIDE.

BST: ARC TO THE NEAR HIP OF THE MAN THE CENTER BLOCKS AND SEAL THE A-B GAP.

G:

FSG: VS. ODD- DOUBLE THE NG WITH THE CENTER. VS. EVEN – BLOCK THE 1ST LB INSIDE.

BSG: PULL AND TRAP 1ST UGLY SHIRT PAST THE FSG's DOWN BLOCK.

C:

VS. ODD – DOUBLE THE NG W/FSG. VS. EVEN – MOST DANGEROUS SHIRT BACKSIDE.

VS. GUARDS COVERED – BLOCK THE MAN OVER THE PULLING GUARD.

QB:

PIVOT ON PLAYSIDE FOOT. PUSH BALL BACK TO FB W/ONE HAND. FAKE KEEP OUT PLAYSIDE.

RUN OUTSIDE THE WIDEST DEFENDER. SELL FAKE 20 YARDS.

FB:

STEP FORWARD WITH PS FOOT. RUN BETWEEN THE DOWN BLOCK AND THE TRAPPING GUARD.

STAY IN THE FUNEL AND KEEP THE BALL WRAPPED UNTIL YOU KNOW YOU CAN SCORE!

HB:

FSH: RUN THROUGH THE C-GAP AND BLOCK THE DEFENDER IN THE OUTSIDE THIRD OR HALF OF THE FIELD. DO NOT ALLOW DE TO CROSS YOUR FACE!

BSH: CROSS-OVER, POCKET AND RUN OVER THE QB's HANDS. RUN JUST OUTSIDE THE D-END. SELL FAKE FOR 20 YARDS.



40 TRAP VS 5-2 DEFENSE

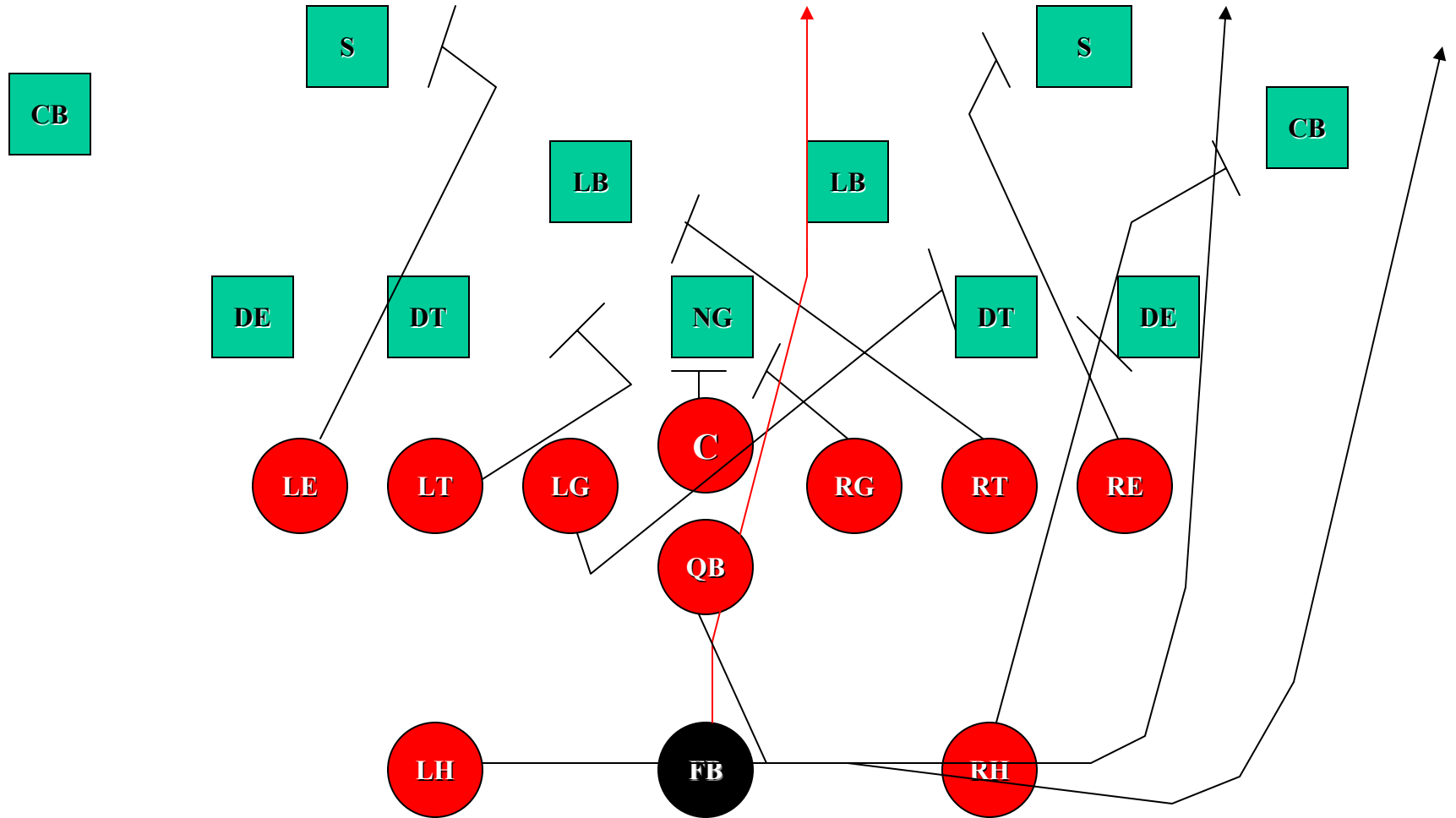

40 TRAP VS. 7-1 DEFENSE

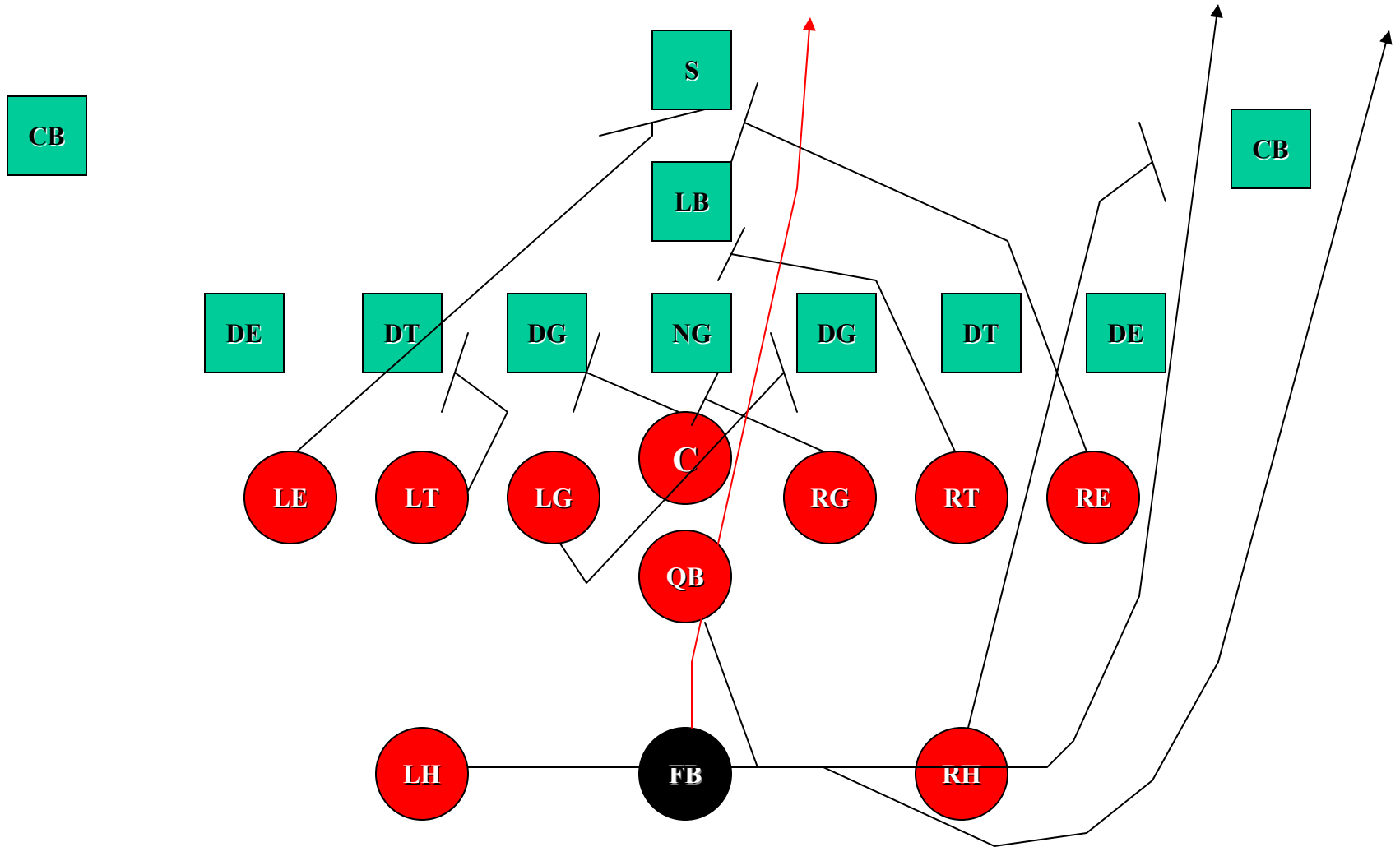

40 TRAP VS. 6-1 DEFENSE

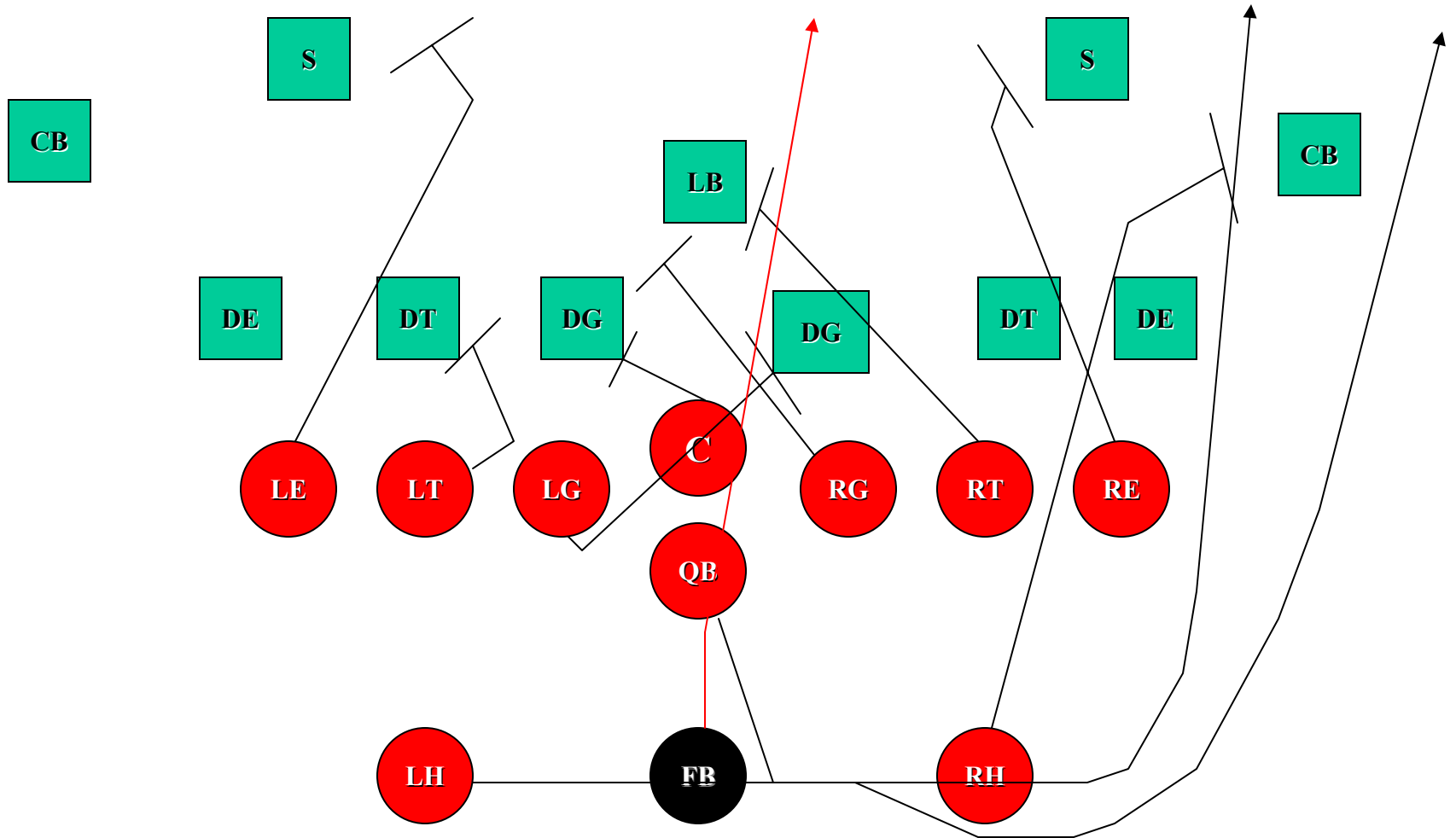

40 TRAP VS. 6-2 DEFENSE

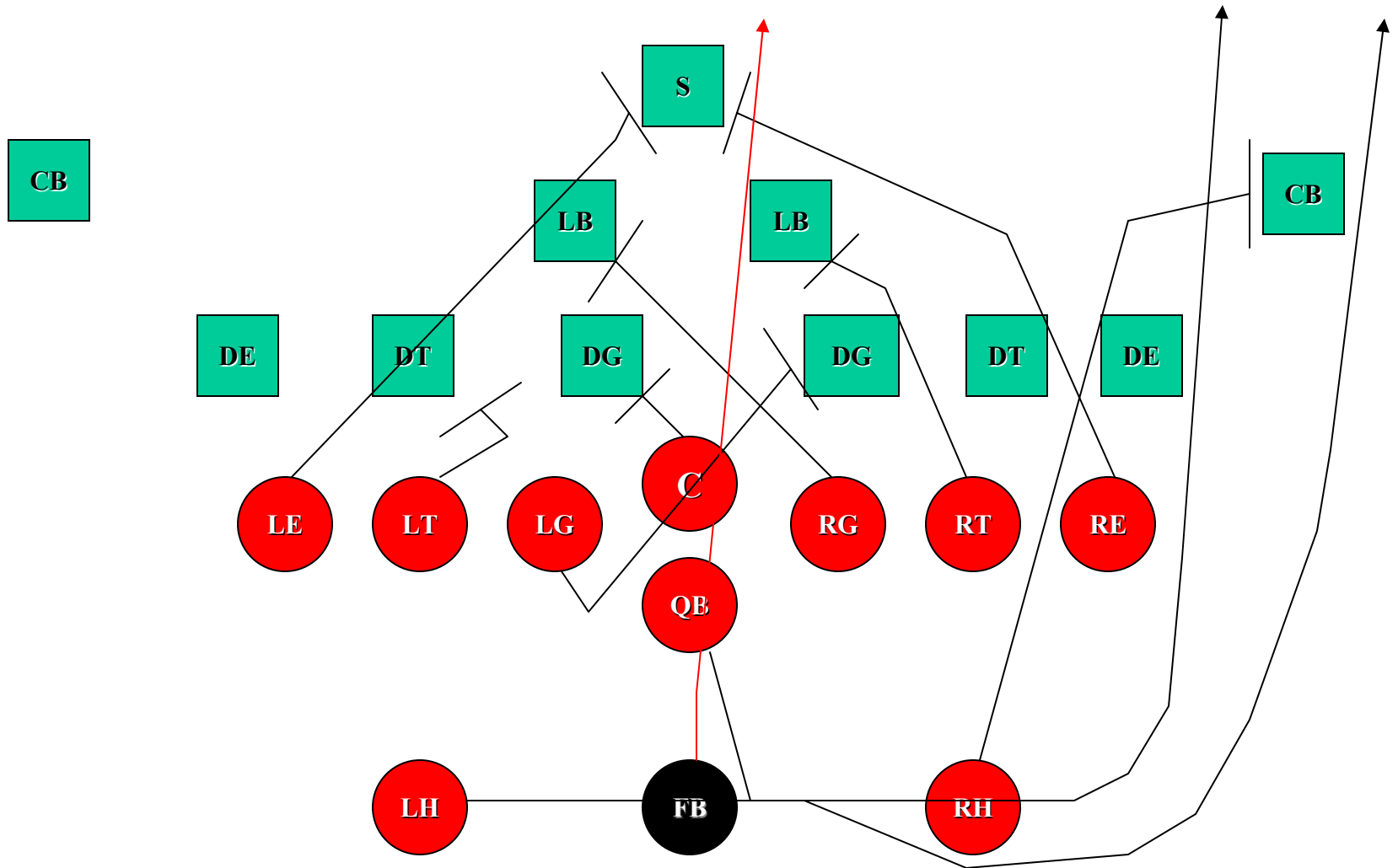

40 TRAP VS. 4-3 DEFENSE

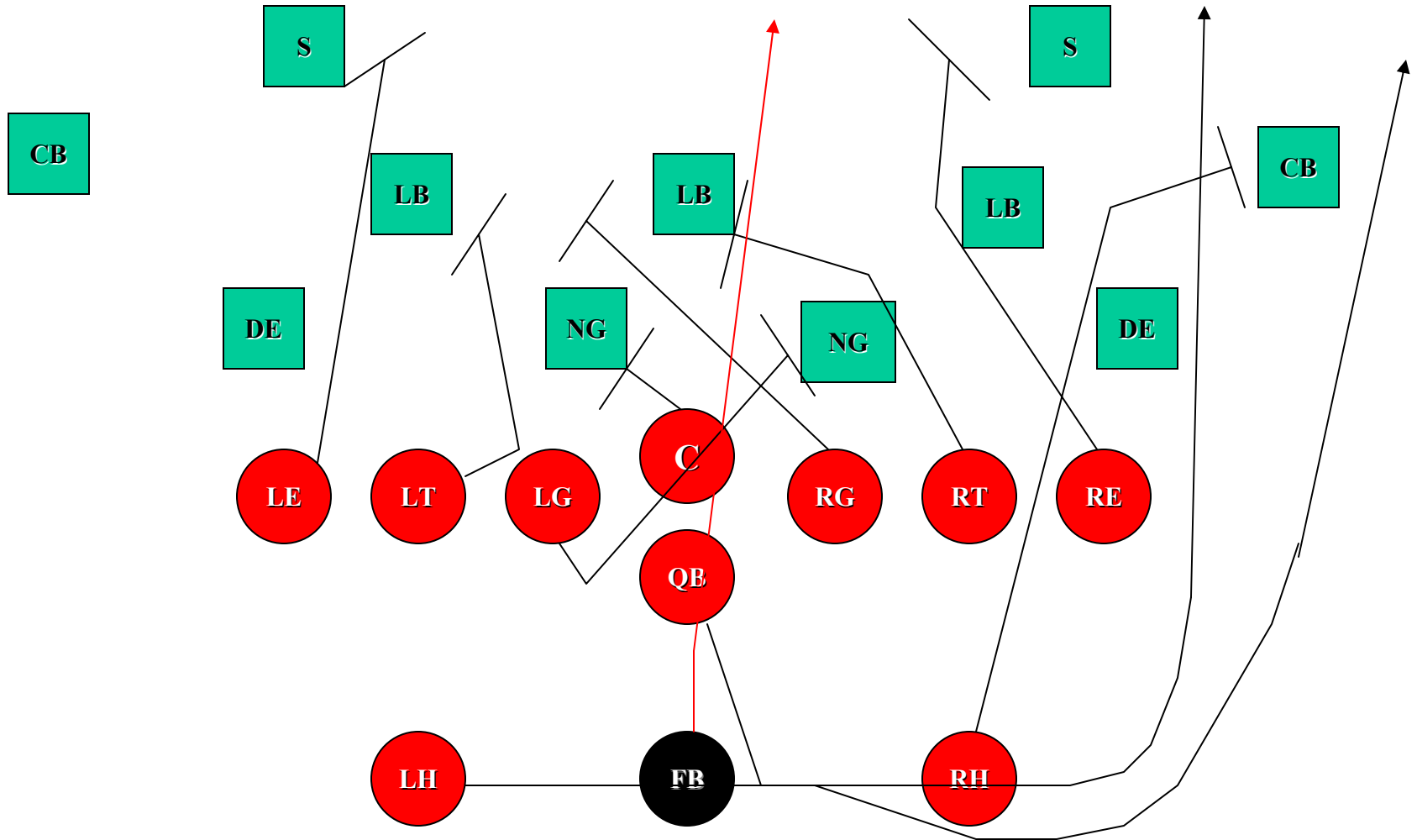

40 TRAP VS. 4-4 DEFENSE

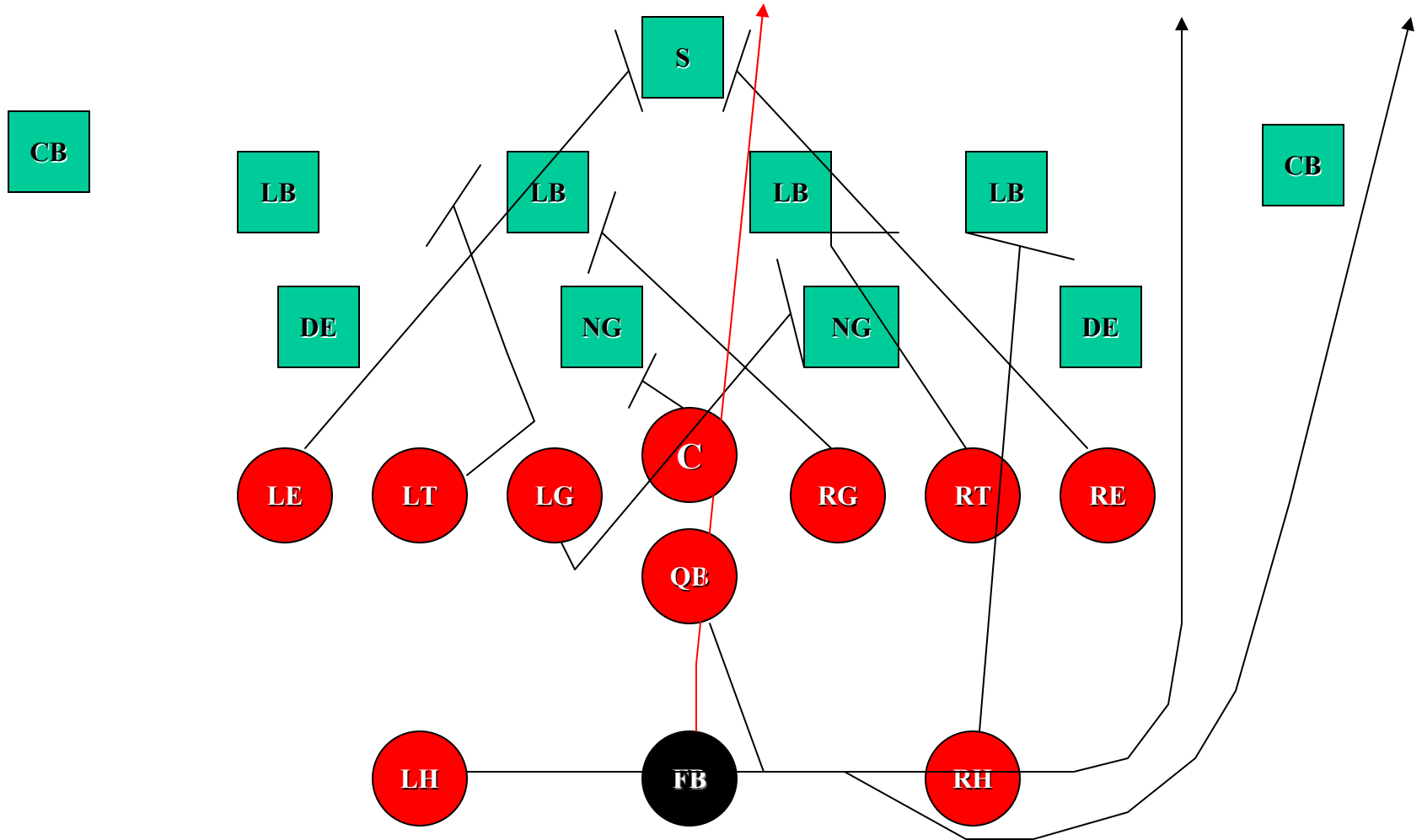

40 – 41 STAR RULES

TE:

FSE: BLOCK THE 1ST LB FROM THE CENTER OUT.

BSE: BLOCK THE DEFENDER IN THE MIDDLE THIRD OR HALF OF THE FIELD.

T:

FST: BUILD A WALL WITH THE CENTER AND LOOK FOR THE 1ST LB INSIDE.

BST: ARC TO THE NEAR HIP OF THE MAN THE CENTER BLOCKS AND SEAL THE A-B GAP.

G:

FSG: INFLUENCE PULL AND BLOCK THE FORCE. VS. G's COVERED OR A 1 TECHNIQUE PS BLOCK NORMAL TRAP RULE

BSG: PULL AND TRAP 1ST UGLY SHIRT PAST THE CENTER.

C:

VS. ODD – SINGLE THE NOSE. VS. EVEN – MOST DANGEROUS SHIRT BACKSIDE.

VS. GUARDS COVERED OR A 1 TECHNIQUE PLAYSIDE, BLOCK NORMAL TRAP RULE.

QB:

PIVOT ON PLAYSIDE FOOT. PUSH BALL BACK TO FB W/ONE HAND. FAKE TO BOTH HB's AND FAKE KEEP OUT PLAYSIDE.

RUN OUTSIDE THE WIDEST DEFENDER. SELL FAKE FOR 20 YARDS.

FB:

STEP FORWARD WITH PS FOOT. RUN BETWEEN THE FST'S BLOCK AND THE TRAPPING GUARD.

STAY IN THE FUNEL AND KEEP THE BALL WRAPPED UNTIL YOU KNOW YOU CAN SCORE!

HB:

FSH: DROP STEP AND FAKE REVERSE BACKSIDE. ROCK THE CRADLE OUTSIDE D-END. SELL FAKE FOR 20 YARDS.

BSH: CROSS-OVER, POCKET AND RUN OVER THE QB's HANDS. RUN JUST OUTSIDE THE D-END SELL FAKE FOR 20 YARDS.

40 STAR VS. 5-2 DEFENSE

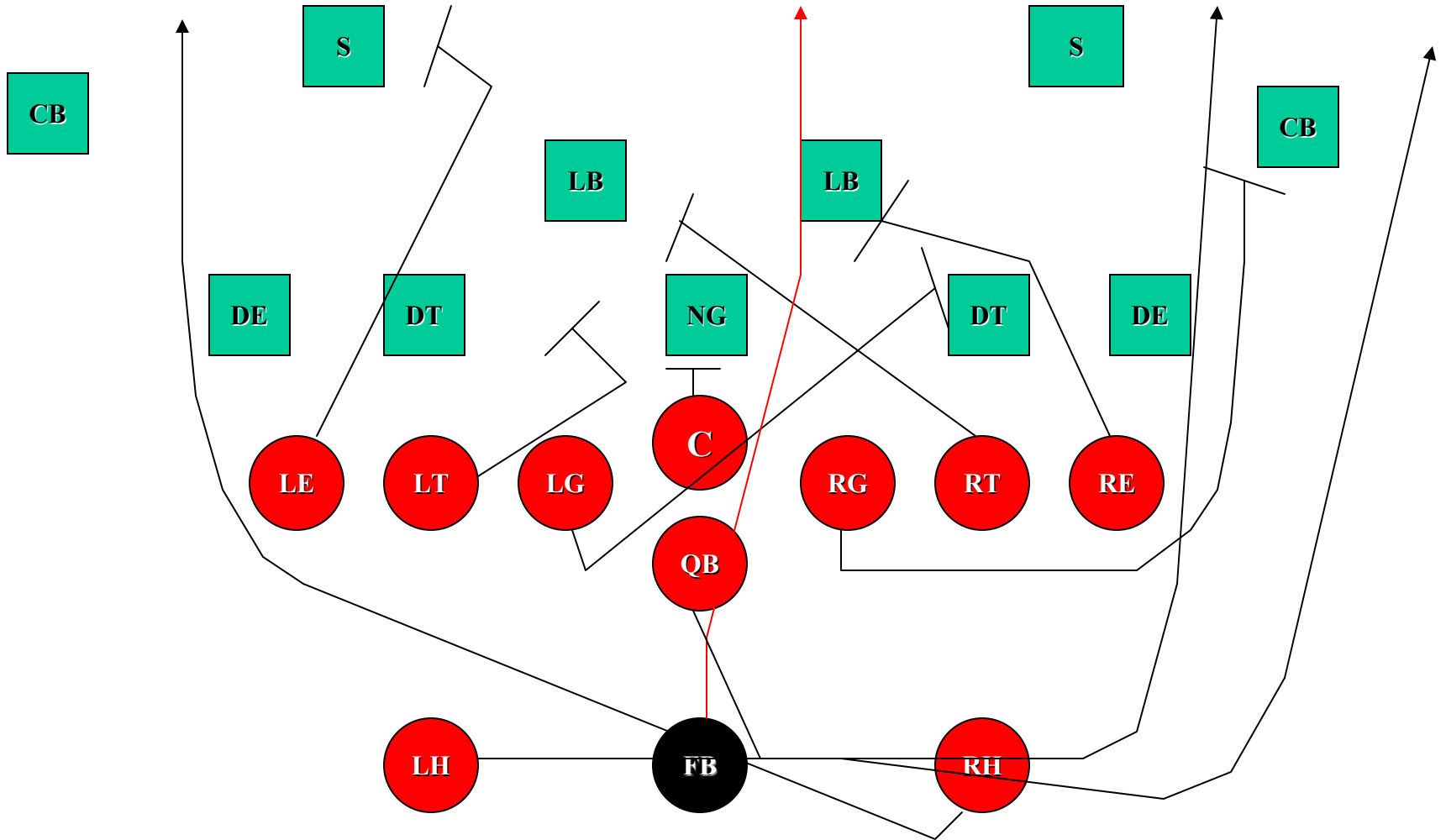

40 STAR VS. 5-3 DEFENSE

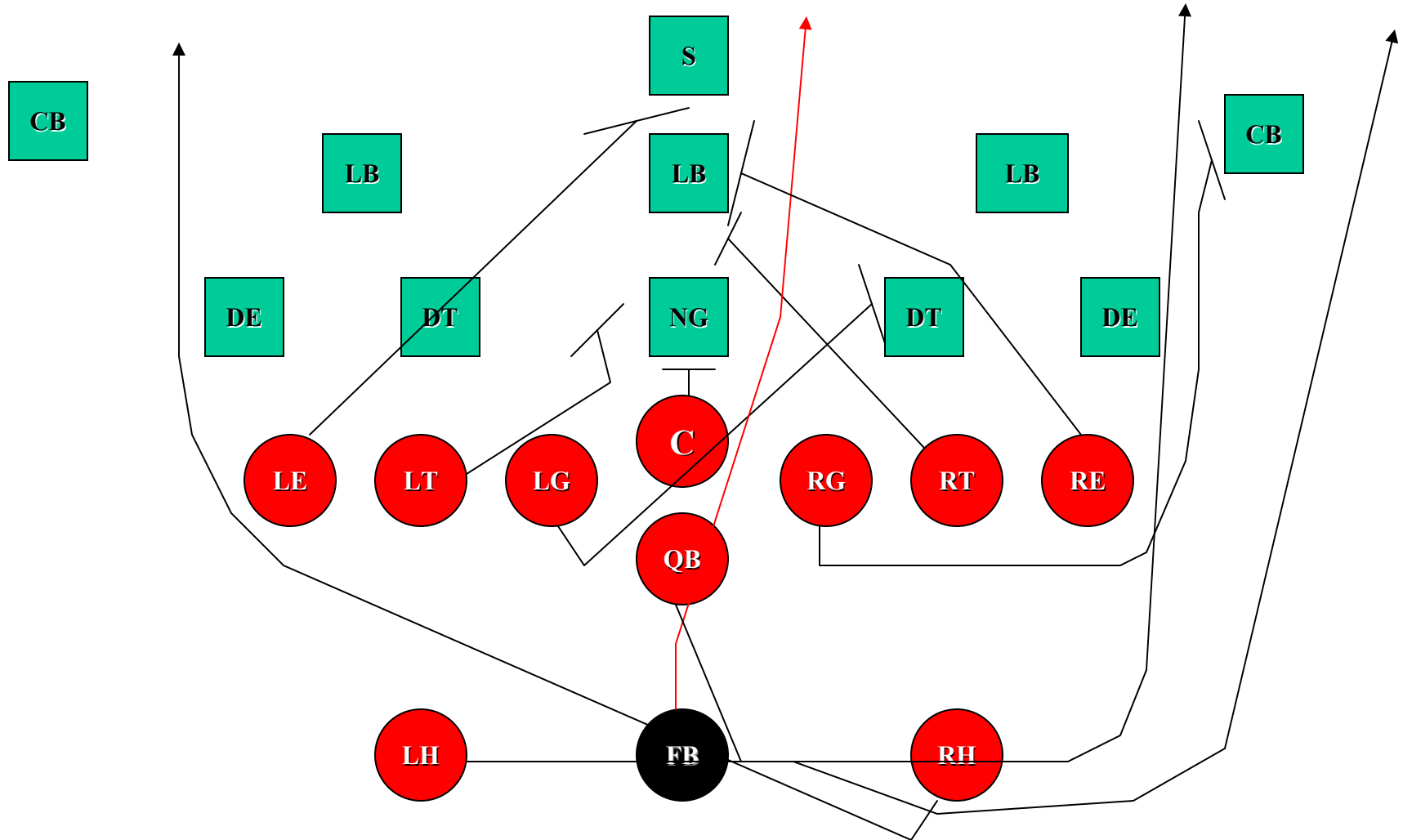

40 STAR VS. 7-1 DEFENSE

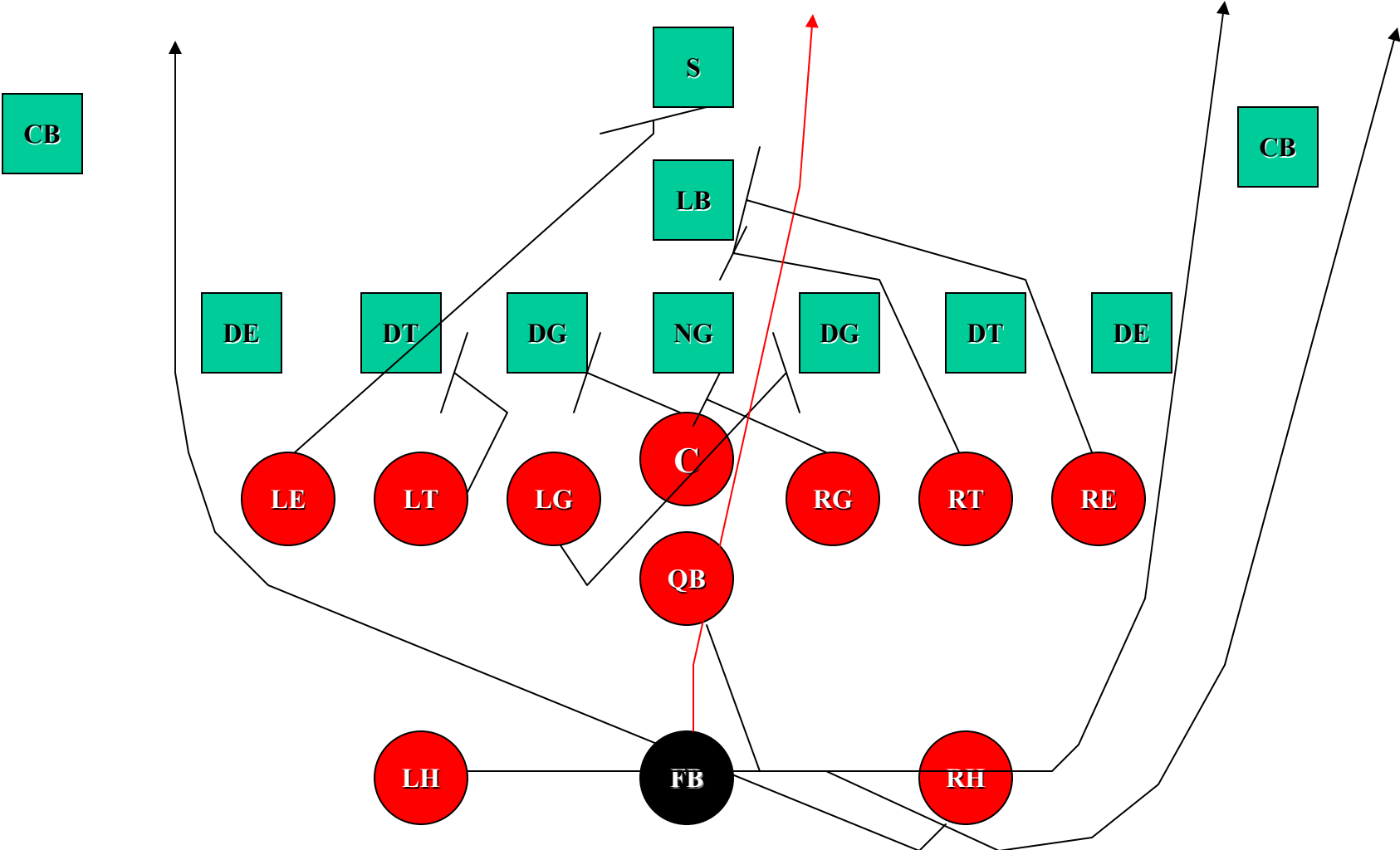

40 STAR VS. 6-1 DEFENSE

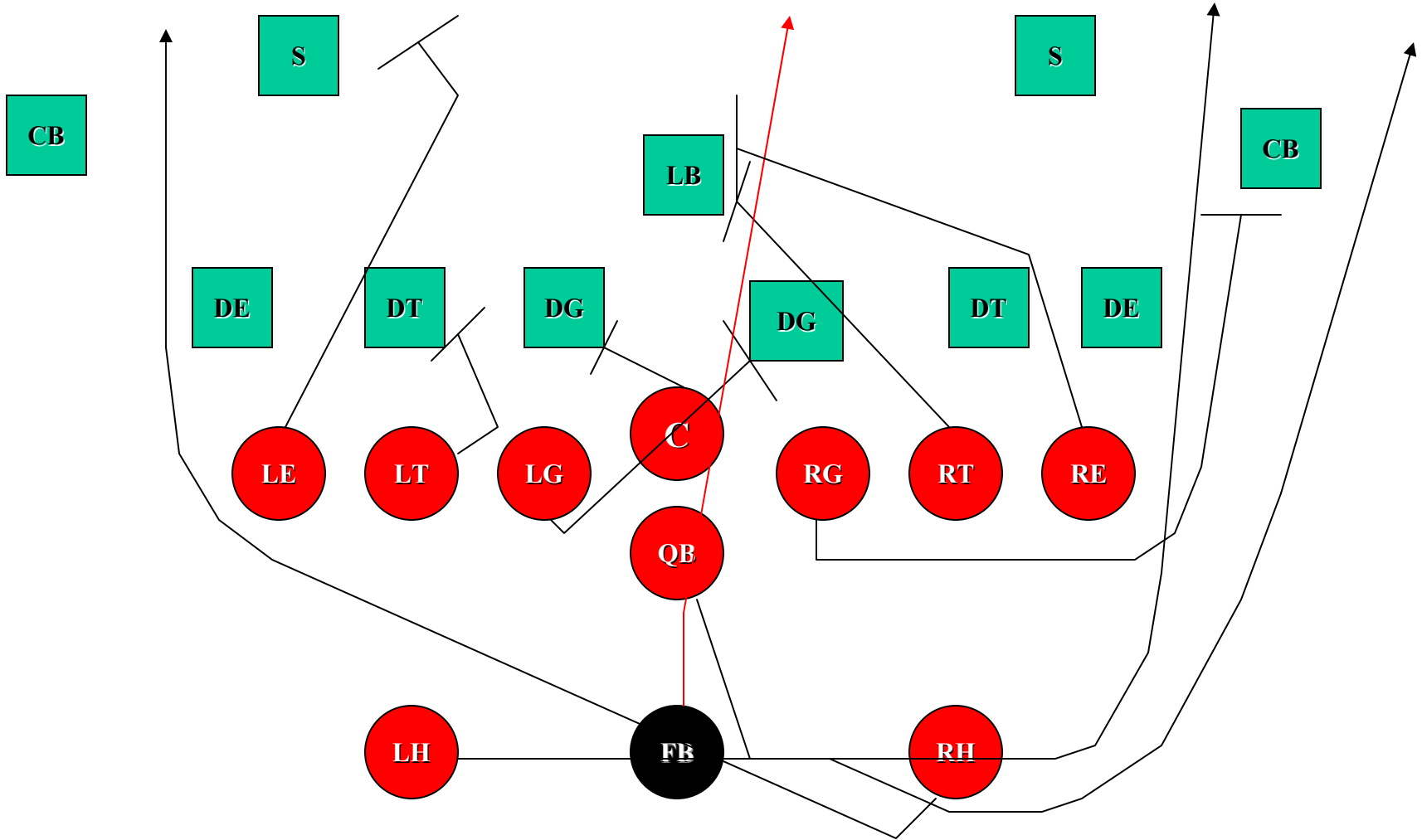

40 STAR VS. 6-2 DEFENSE

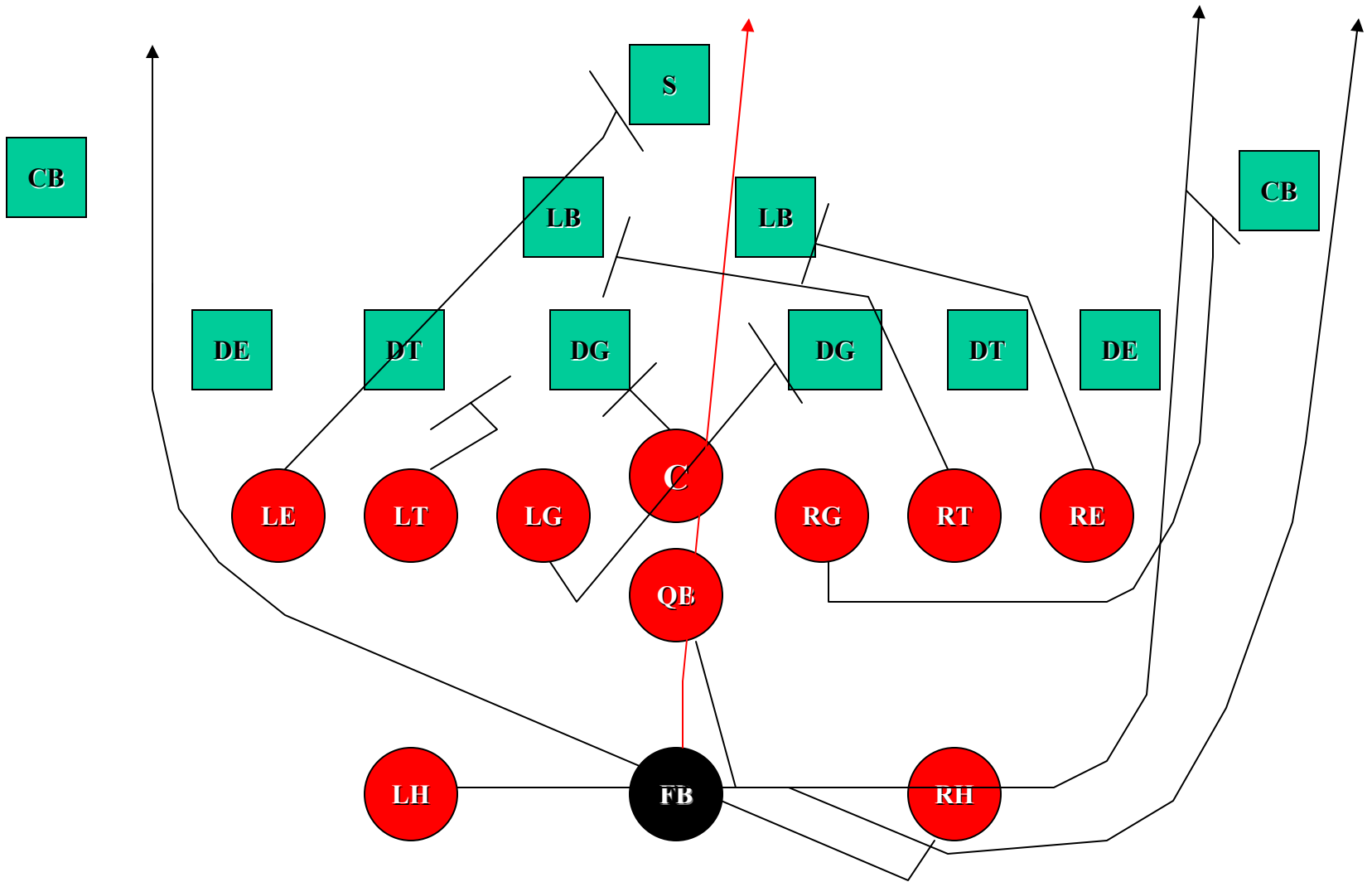

40 STAR VS. 6-5 DEFENSE

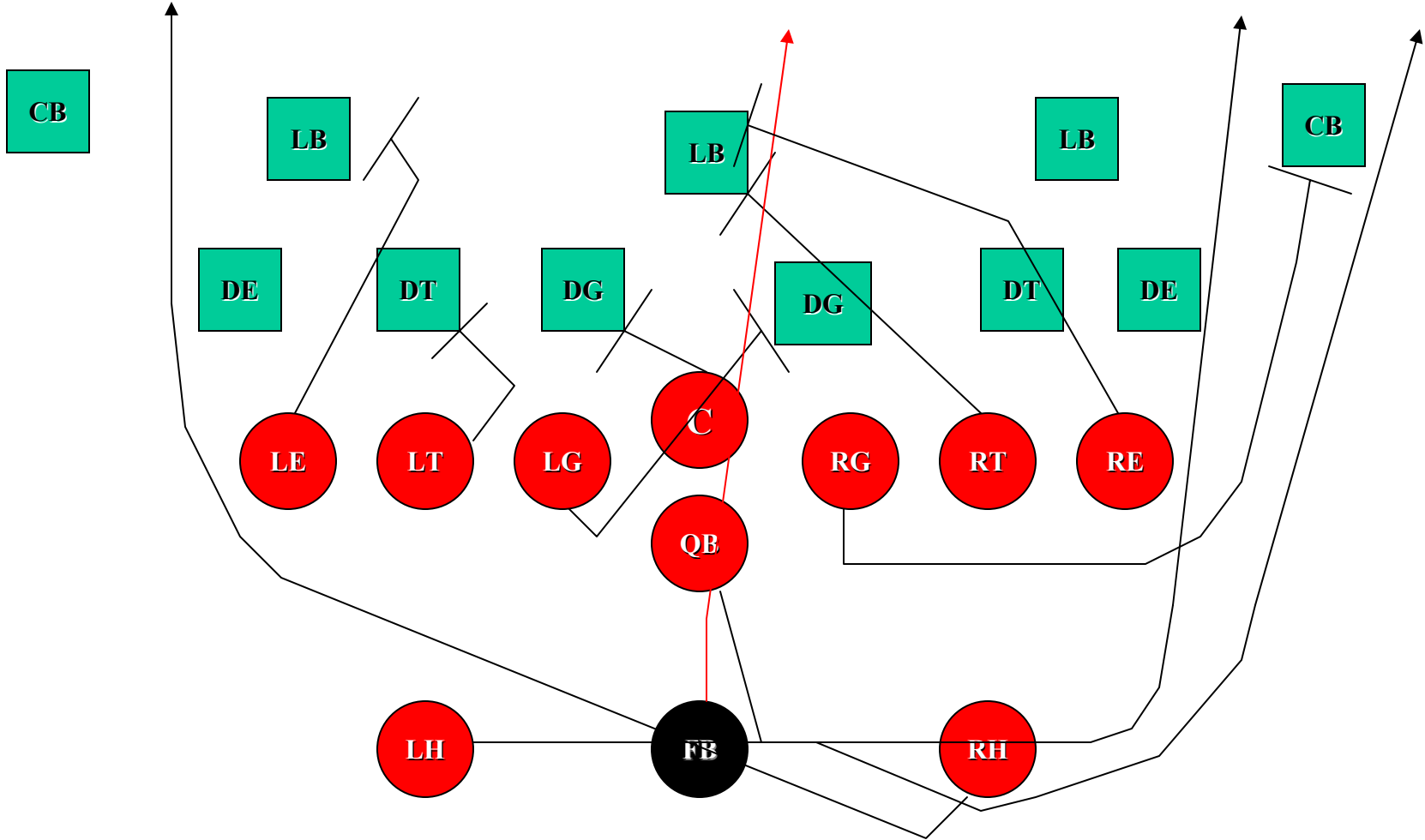

40 STAR VS. 4-3 DEFENSE

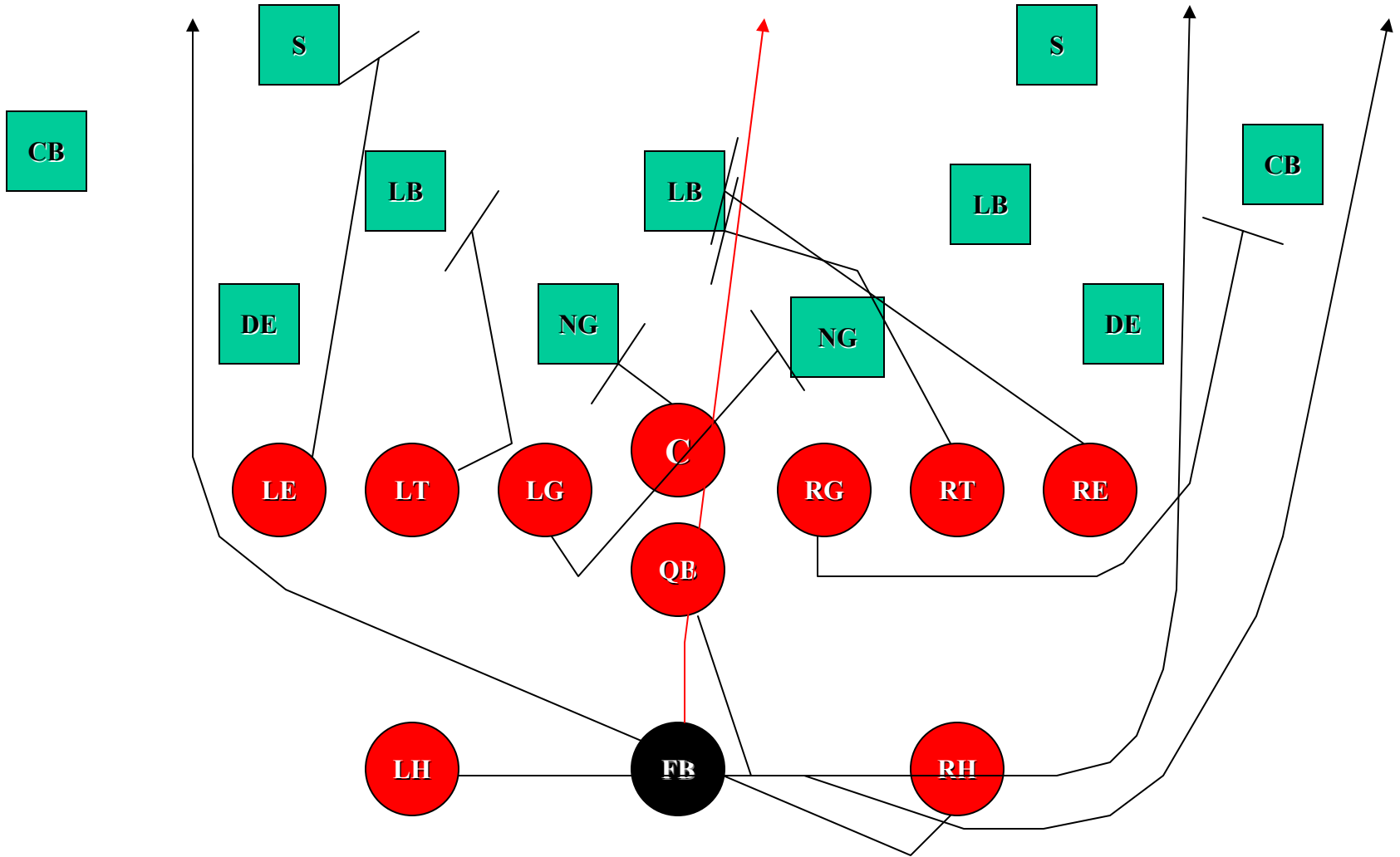

40 – 41 ADJUSTMENTS



40 - 41 BASE RULES

TE:

FSE: BLOCK THE DEFENDER IN THE MIDDLE THIRD OR HALF OF THE FIELD.

BSE: BLOCK THE DEFENDER IN THE MIDDLE THIRD OR HALF OF THE FIELD.

T:

FST: BLOCK THE SECOND MAN OUTSIDE CENTER OR FOLD WITH THE FSG AND LOOK FOR LB. GUARD GOES FIRST!

BST: BLOCK SOLID ON THE 2ND MAN OUTSIDE CENTER OR FOLD WITH THE BSG AND LOOK FOR LB. GUARD GOES FIRST!

G:

FSG: BLOCK THE 1ST MAN OUTSIDE CENTER OR FOLD WITH THE FST AND BLOCK MAN OVER HIM.

BSG: BLOCK SOLID ON THE 1ST MAN OUTSIDE CENTER OR FOLD WITH THE BST AND BLOCK MAN OVER HIM.

C:

VS. ODD – BLOCK THE NG ANY WAY YOU CAN. **VS. EVEN** – BLOCK THE BACKSIDE LB.

VS. GUARDS COVERED – BLOCK THE MAN OVER YOU. THE FB IS READING YOUR BLOCK!

QB:

PIVOT ON PLAYSIDE FOOT. PUSH BALL BACK TO FB W/ONE HAND. FAKE KEEP OUT PLAYSIDE.

RUN OUTSIDE THE WIDEST DEFENDER. SELL FAKE FOR 20 YARDS.

FB:

STEP FORWARD WITH PS FOOT. READ THE BLOCK OF THE CENTER AND RUN TOWARD HIS HAT.

STAY IN THE FUNEL AND KEEP THE BALL WRAPPED UNTIL YOU KNOW YOU CAN SCORE!

HB:

FSH: RUN THROUGH C-GAP AND BLOCK DEFENDER IN OUTSIDE THIRD OR HALF OF THE FIELD. DO NOT LET DE CROSS YOUR FACE!

BSH: CROSS-OVER, POCKET AND RUN OVER THE QB's HANDS. RUN JUST OUTSIDE THE D-END. SELL FAKE FOR 20 YARDS.

40 BASE VS. 5-2 DEFENSE

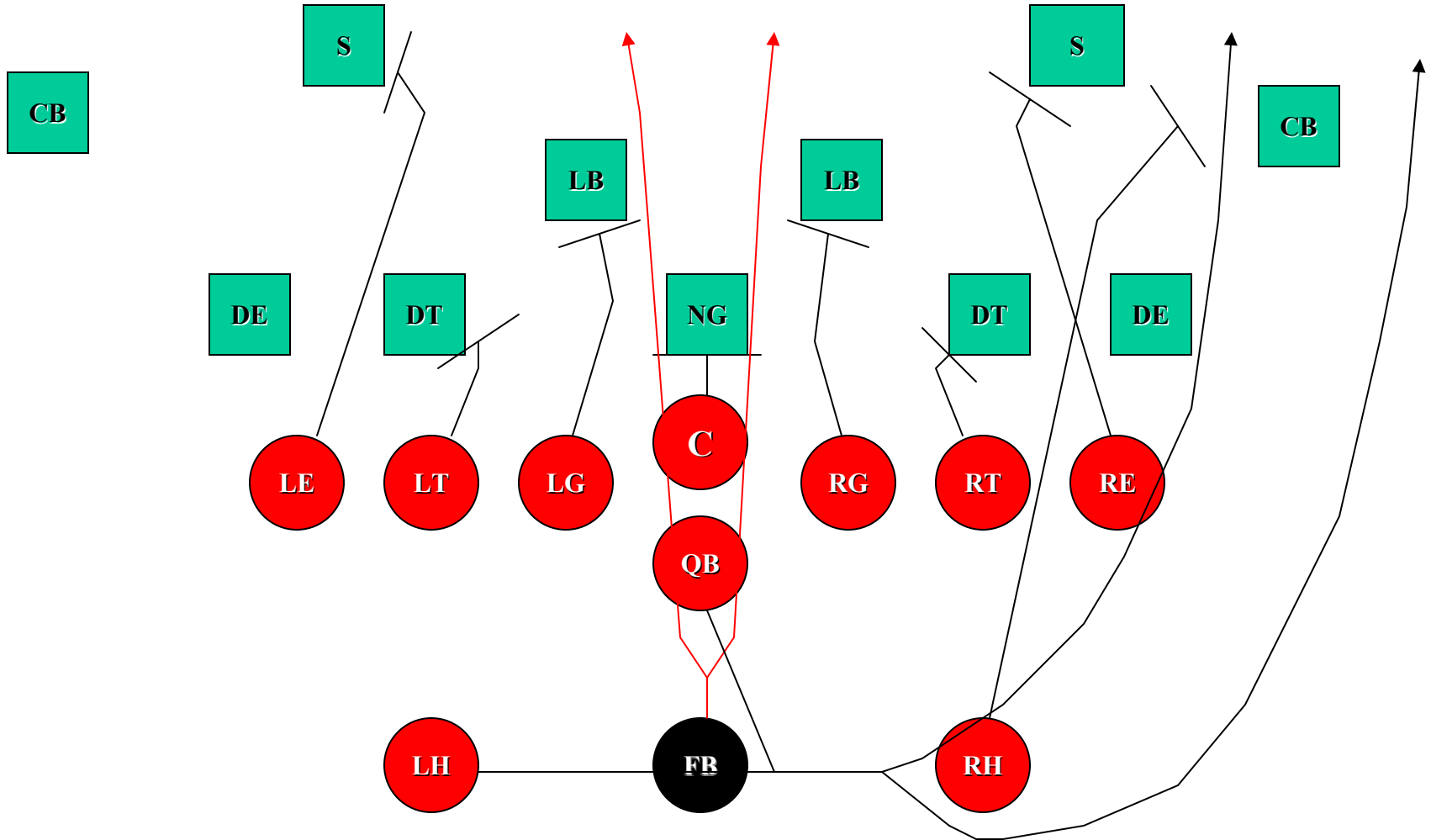

40 BASE VS 5-3 DEFENSE

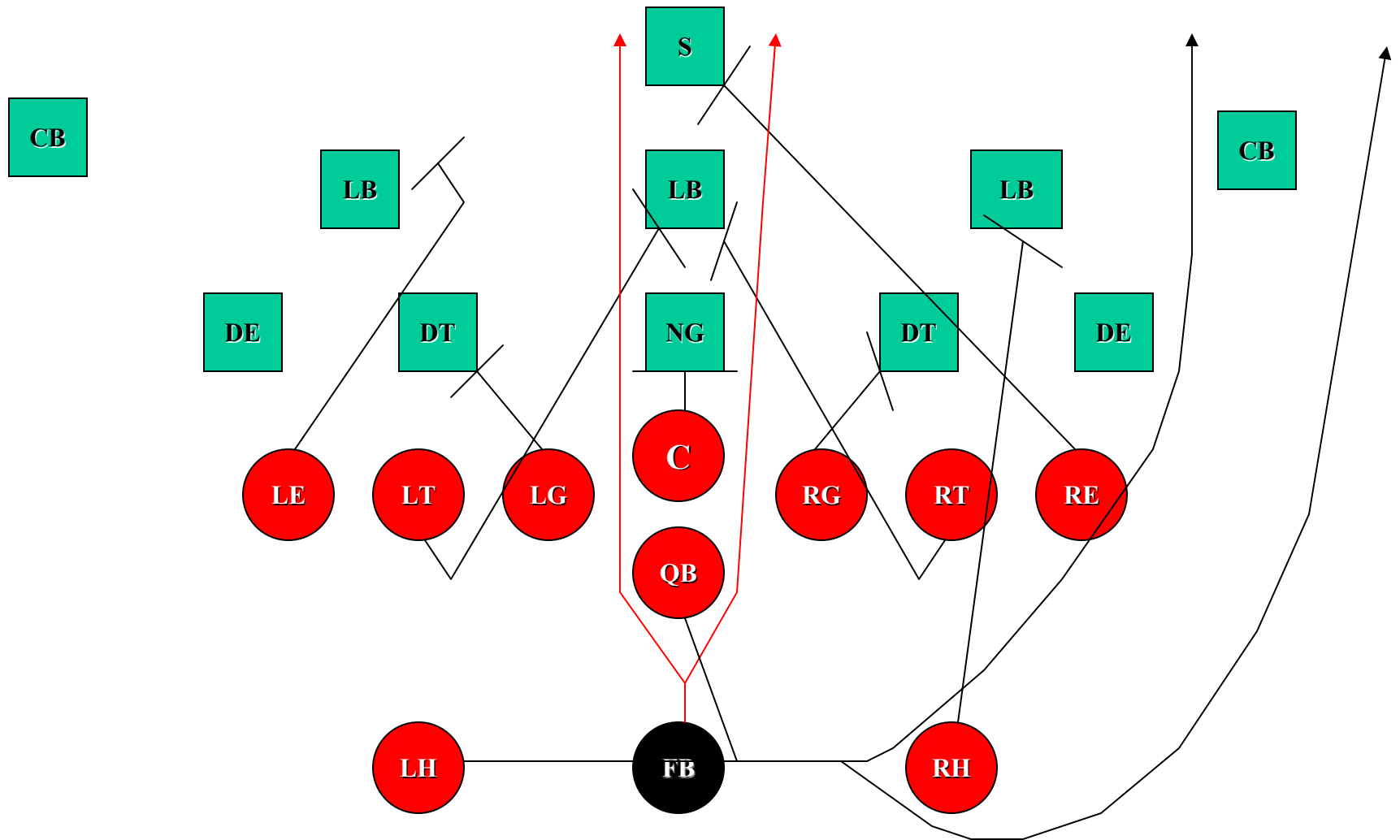



40 - 41 GUT RULES

TE:

FSE: BLOCK THE DEFENDER IN THE MIDDLE THIRD OR HALF OF THE FIELD.

BSE: BLOCK THE DEFENDER IN THE MIDDLE THIRD OR HALF OF THE FIELD.

T:

FST: BLOCK DOWN ON THE 1ST LB INSIDE. DO NOT LET A D-LINEMAN CROSS YOUR FACE!

BST: ARC TO THE NEAR HIP OF THE MAN THE CENTER BLOCKS AND SEAL THE A-B GAP.

G:

FSG: BLOCK THE DOWN LINEMAN OVER YOU.

BSG: DROP STEP AND PULL AROUND THE CENTER'S BLOCK. LOOK FOR THE 1ST UGLY SHIRT. PROBABLY A LB.

C:

BLOCK THE MOST DANGEROUS SHIRT BACKSIDE.

VS. ODD OR GUARDS COVERED
- CALL REGULAR OR BASE.

QB:

PIVOT ON PLAYSIDE FOOT. PUSH BALL BACK TO FB W/ONE HAND. FAKE KEEP OUT PLAYSIDE.

RUN OUTSIDE THE WIDEST DEFENDER. SELL FAKE 20 YARDS.

FB:

STEP FORWARD WITH PS FOOT. READ THE GUT BLOCK OF THE PULLING GUARD ON THE LB.

STAY IN THE FUNEL AND KEEP THE BALL WRAPPED UNTIL YOU KNOW YOU CAN SCORE!

HB:

FSH: RUN THROUGH THE C-GAP AND BLOCK THE DEFENDER IN THE OUTSIDE THIRD OR HALF OF THE FIELD. DO NOT ALLOW DE TO CROSS YOUR FACE!

BSH: CROSS-OVER, POCKET AND RUN OVER THE QB'S HANDS. RUN JUST OUTSIDE THE D-END. SELL FAKE FOR 20 YARDS.

40 GUT VS. 6-2 DEFENSE

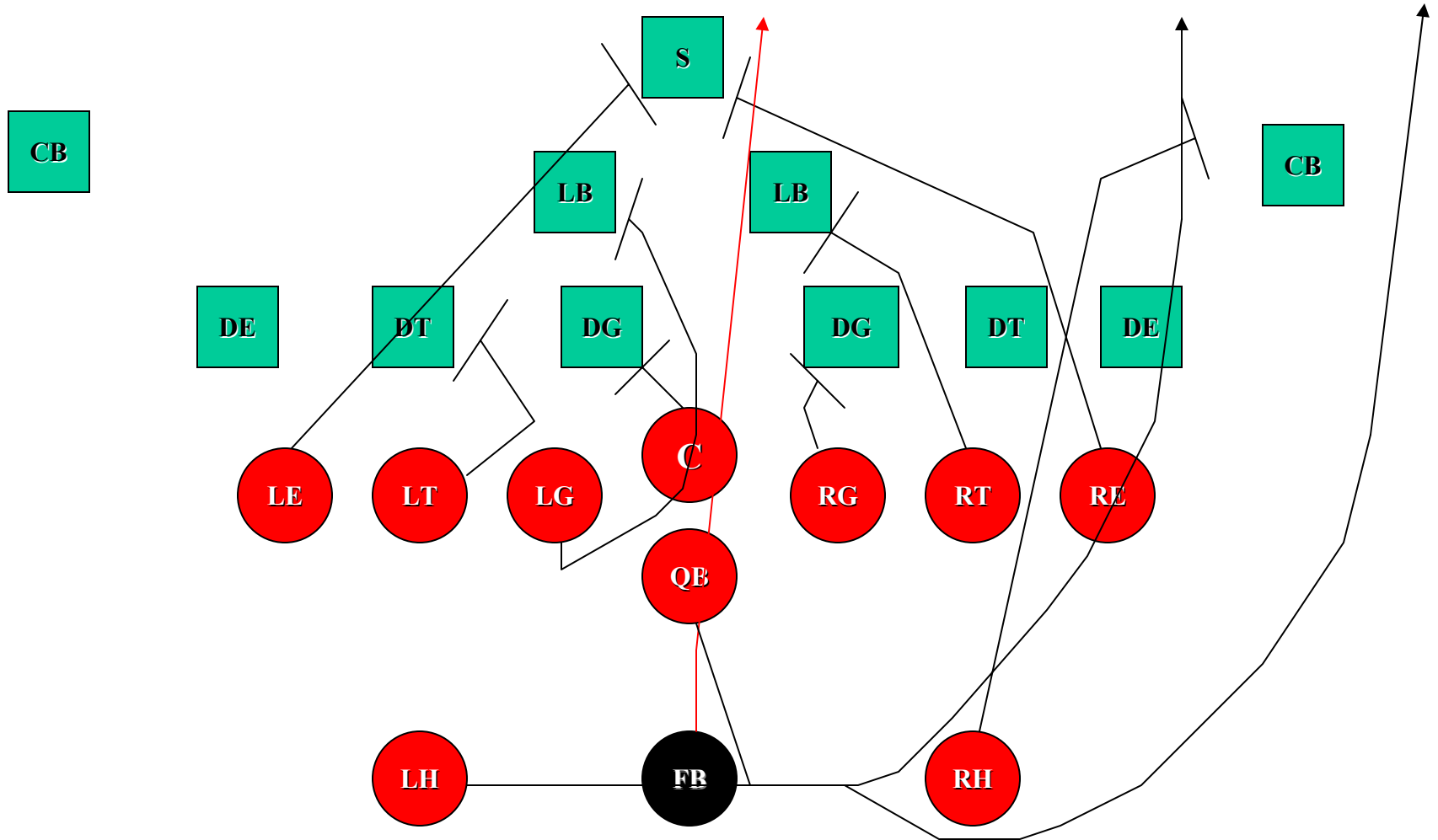

40 GUT VS. 6-5 DEFENSE

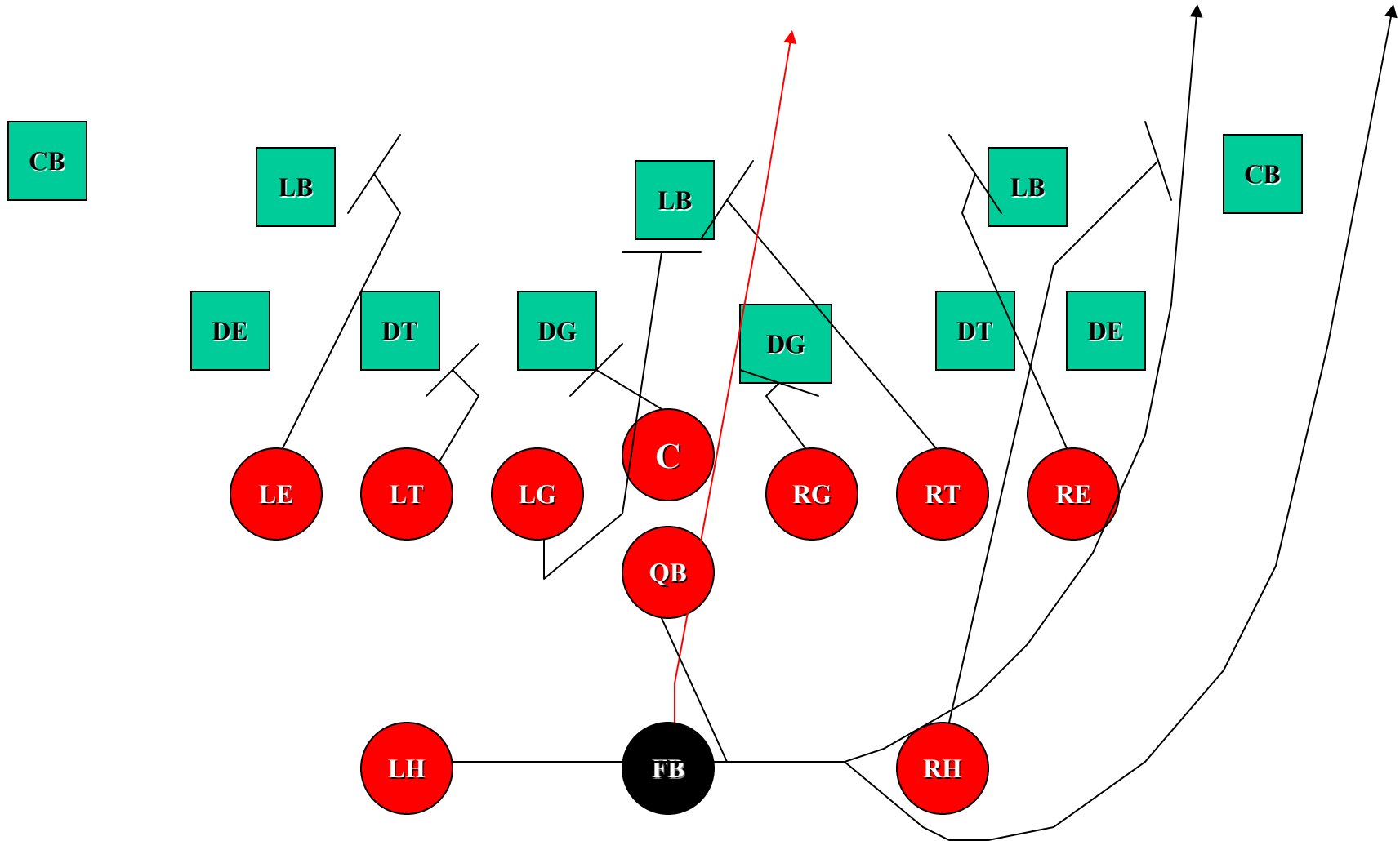

40 - 41 INFLUENCE RULES

TE:

FSE: BLOCK THE 1ST LB FROM THE CENTER OUT.

BSE: BLOCK THE DEFENDER IN THE MIDDLE THIRD OR HALF OF THE FIELD.

T:

FST: BUILD A WALL WITH THE CENTER AND LOOK FOR THE 1ST LB INSIDE.

BST: ARC TO THE NEAR HIP OF THE MAN THE CENTER BLOCKS AND SEAL THE A-B GAP.

G:

FSG: INFLUENCE PULL AND BLOCK THE FORCE. VS. G'S COVERED OR A 1 TECHNIQUE BLOCK NORMAL TRAP RULE.

BSG: PULL AND TRAP 1ST UGLY SHIRT PAST THE CENTER.

C:

VS. ODD – SINGLE THE NOSE. VS. EVEN – MOST DANGEROUS SHIRT BACKSIDE.

VS. GUARDS COVERED OR A 1 TECHNIQUE PLAYSIDE, BLOCK NORMAL TRAP RULE.

QB:

PIVOT ON PLAYSIDE FOOT. PUSH BALL BACK TO FB W/ONE HAND. FAKE KEEP OUT PLAYSIDE.

RUN OUTSIDE THE WIDEST DEFENDER. SELL FAKE 20 YARDS.

FB:

STEP FORWARD WITH PS FOOT. RUN BETWEEN THE DOWN BLOCK AND THE TRAPPING GUARD.

STAY IN THE FUNEL AND KEEP THE BALL WRAPPED UNTIL YOU KNOW YOU CAN SCORE!

HB:

FSH: RUN THROUGH THE C-GAP AND BLOCK THE DEFENDER IN THE MIDDLE THIRD OR HALF OF THE FIELD. DO NOT ALLOW DE TO CROSS YOUR FACE!

BSH: CROSS-OVER, POCKET AND RUN OVER THE QB'S HANDS. RUN JUST OUTSIDE THE D-END. SELL FAKE FOR 20 YARDS.

40 INFLUENCE VS. 5-2

DEFENSE

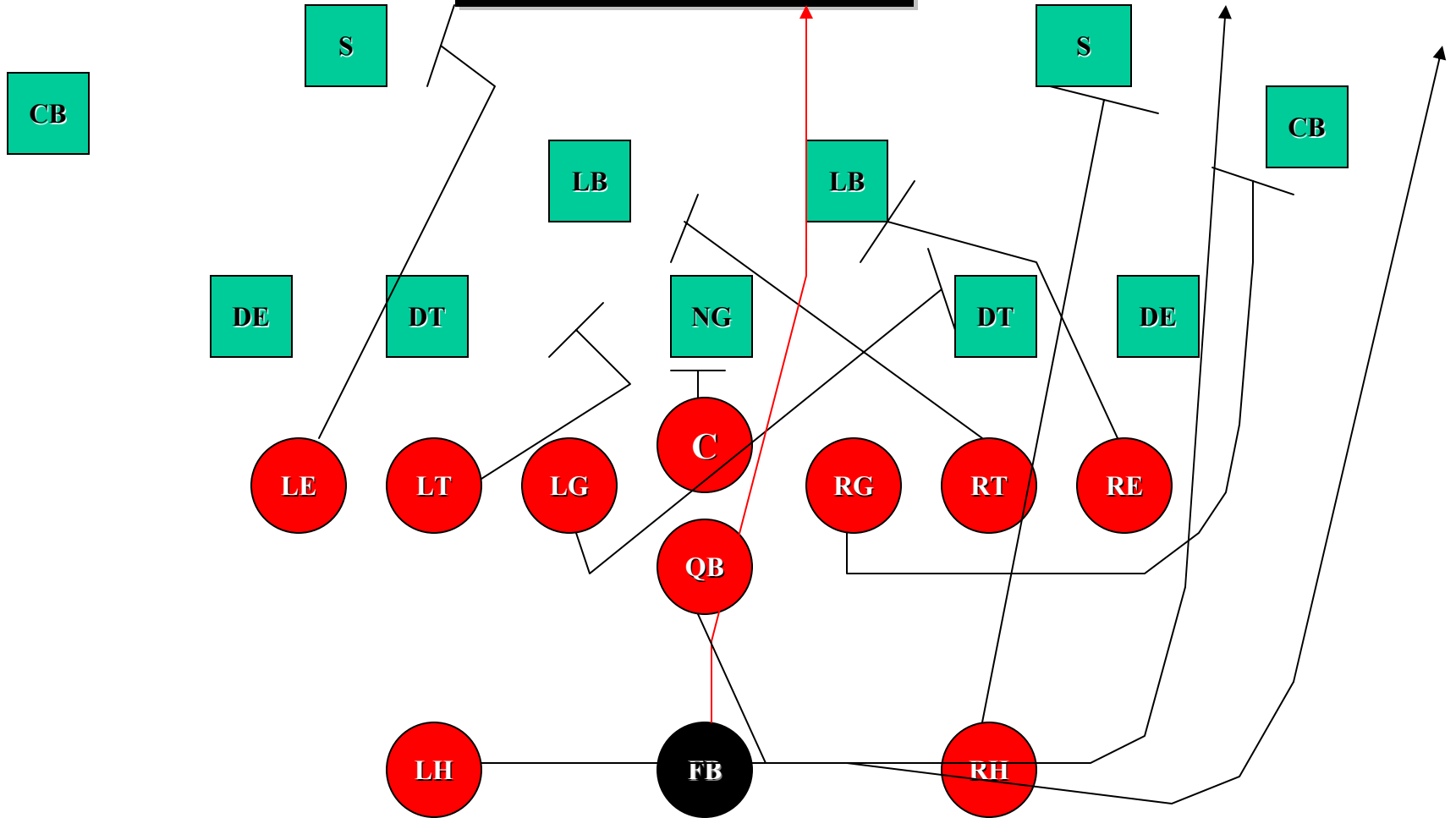

40 INFLUENCE VS. 4-4 DEFENSE

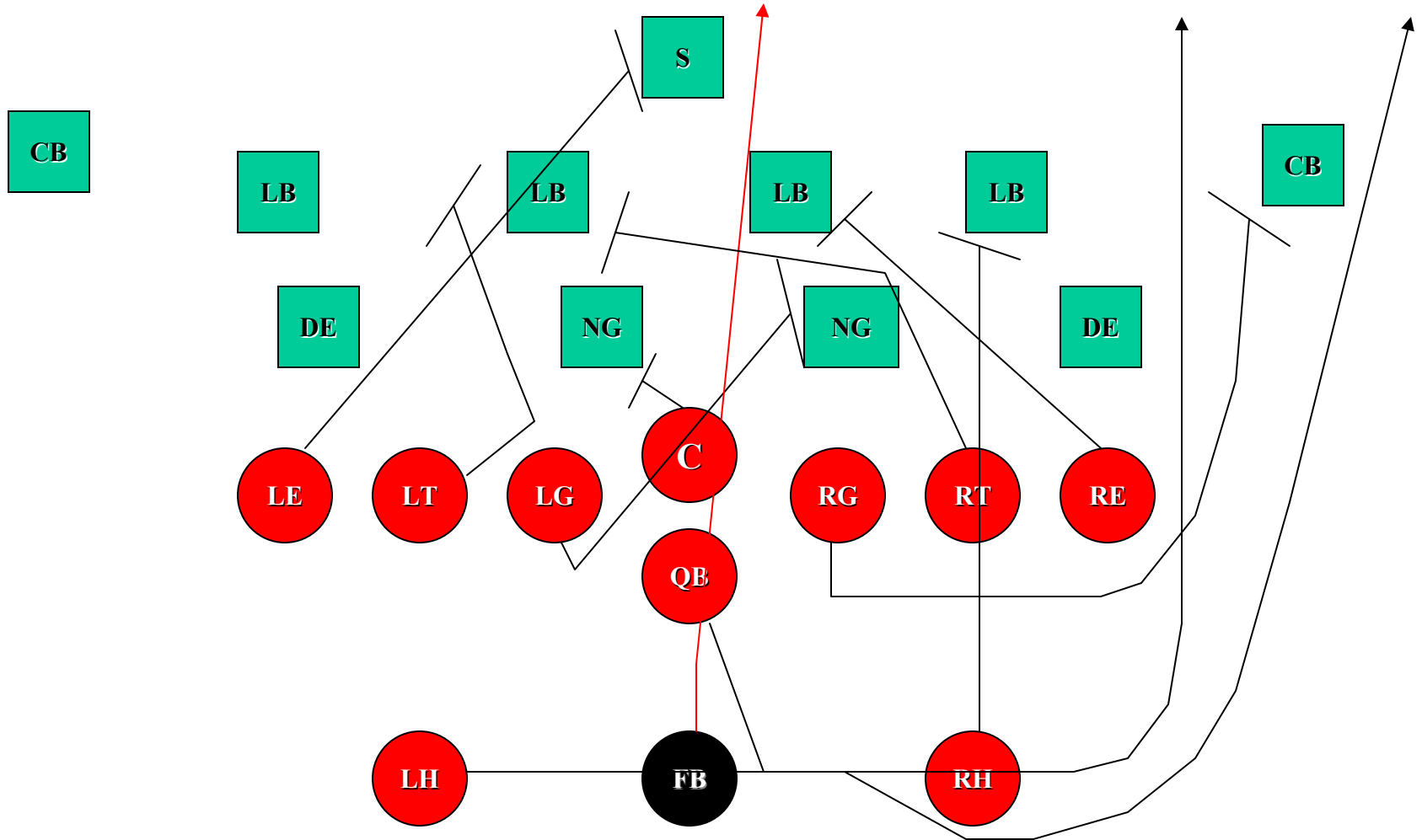

42 - 43 TRAP RULES

TE:

FSE: BLOCK THE 1ST LB FROM THE CENTER OUT.

BSE: BLOCK THE DEFENDER IN THE MIDDLE THIRD OR HALF OF THE FIELD.

T:

FST: BLOCK DOWN ON 1ST DL INSIDE. IF INSIDE FSG LOOK FOR 1ST LB INSIDE.

BST: ARC TO THE NEAR HIP OF THE MAN THE CENTER BLOCKS AND SEAL THE A-B GAP.

G:

FSG: DOUBLE A 3 TECH. W/FST, SINGLE A 2 TECH. DOUBLE NOSE W/CENTER VS. ODD FRONT.

BSG: PULL AND TRAP 1ST UGLY SHIRT PAST THE FST'S DOWN BLOCK.

C:

VS. ODD – DOUBLE THE NOSE W/FSG. **VS. EVEN** – MOST DANGEROUS SHIRT BACKSIDE.

VS. GUARDS COVERED – BLOCK THE MAN OVER THE PULLING GUARD.

QB:

PIVOT ON PLAYSIDE FOOT. PUSH BALL BACK TO FB W/ONE HAND. FAKE TO BSH AND THEN FAKE BOOT BACKSIDE.

RUN OUTSIDE THE WIDEST DEFENDER. SELL FAKE FOR 20 YARDS.

FB:

STEP FORWARD WITH PS FOOT. RUN BETWEEN THE FST'S BLOCK AND THE TRAPPING GUARD.

STAY IN THE FUNEL AND KEEP THE BALL WRAPPED UNTIL YOU KNOW YOU CAN SCORE!

HB:

FSH: J-BLOCK THE DEFENSIVE END ON THE INSIDE NUMBER AND KEEP HIM WHERE HE'S AT OR PUSH HIM OUTSIDE.

BSH: CROSS-OVER, POCKET AND RUN OVER THE QB'S HANDS. RUN JUST OUTSIDE THE D-END. SELL FAKE FOR 20 YARDS.





42 TRAP VS. 5-3 DEFENSE

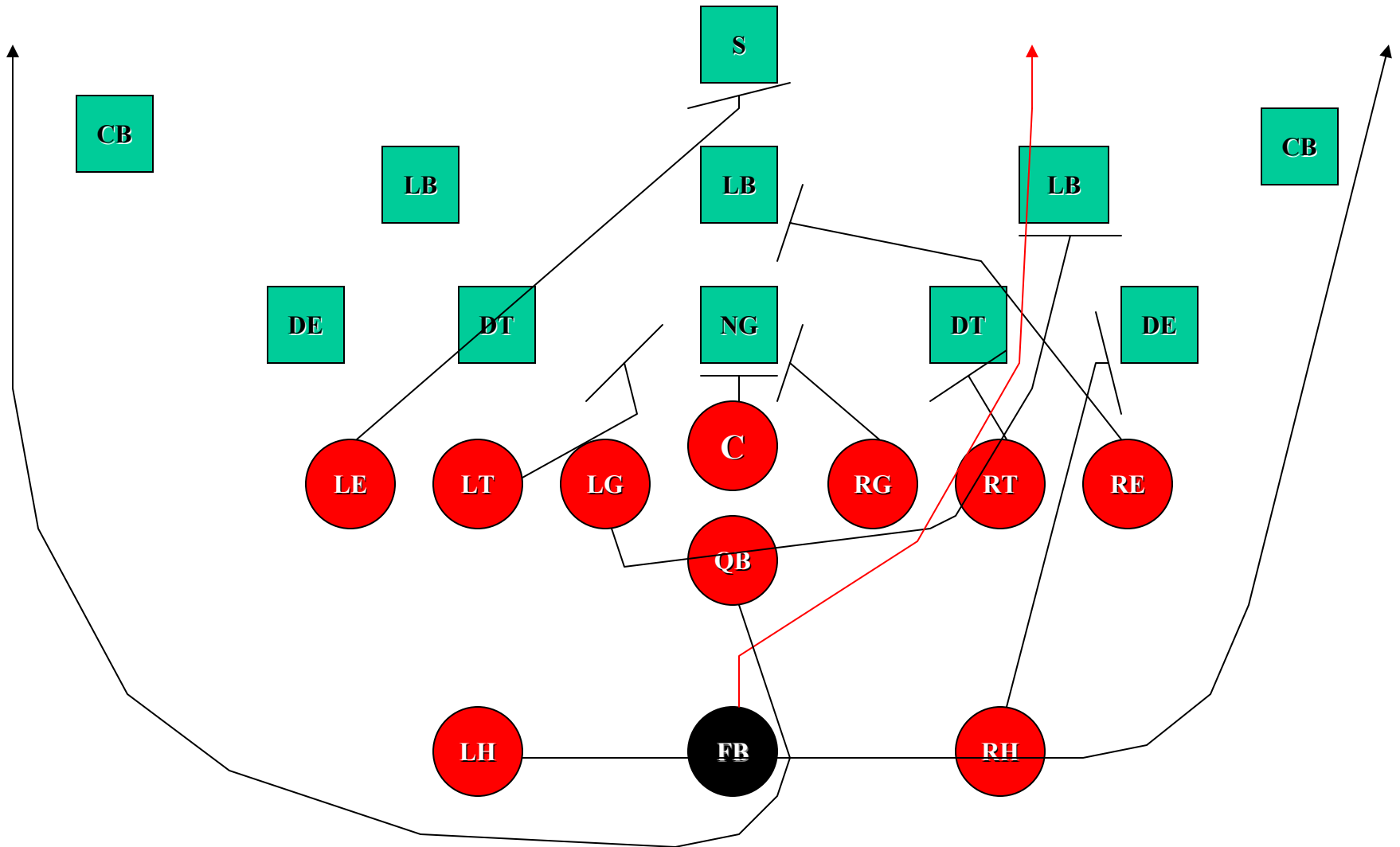

42 TRAP VS. 7-1 DEFENSE

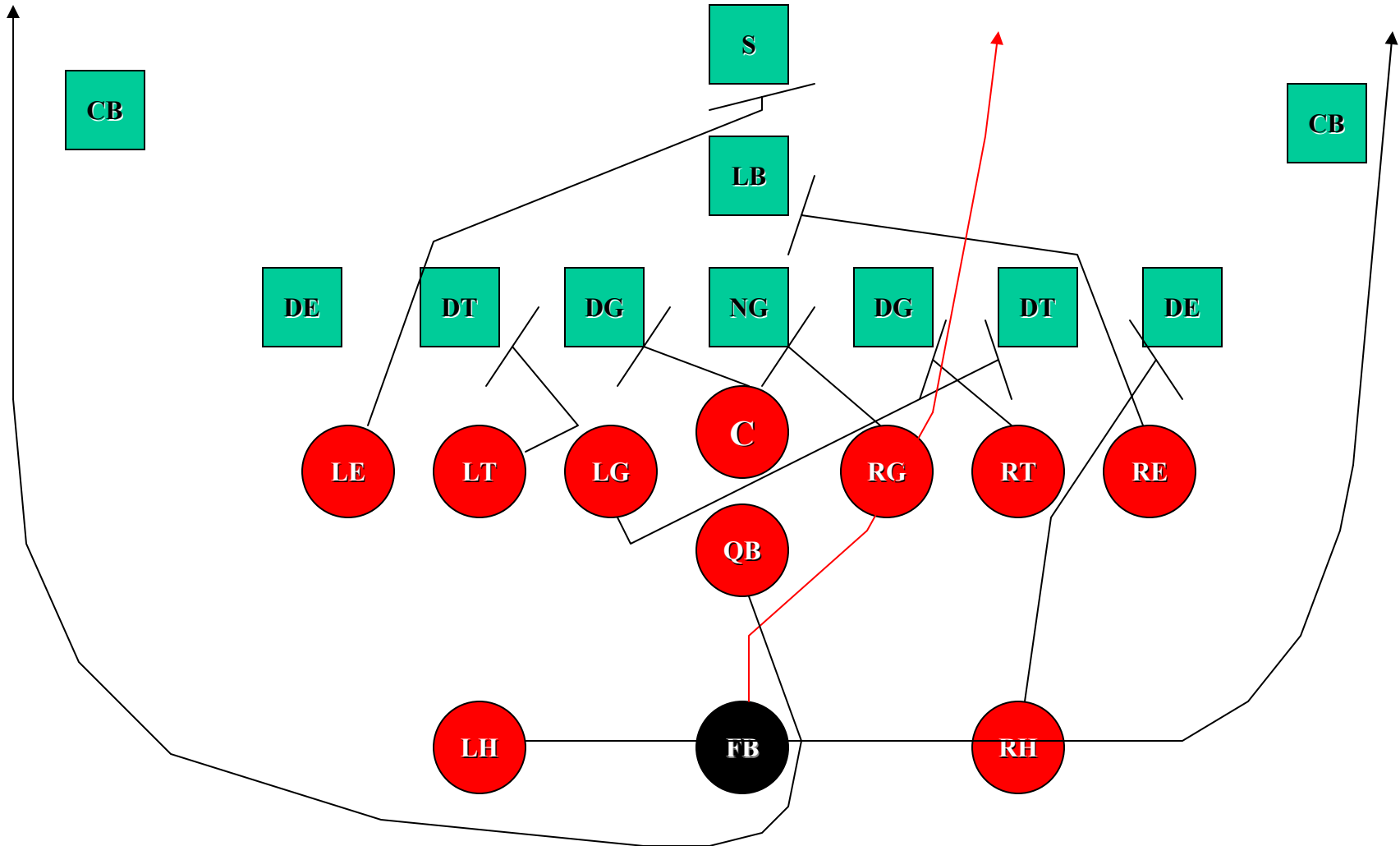

42 TRAP VS. 6-1 DEFENSE

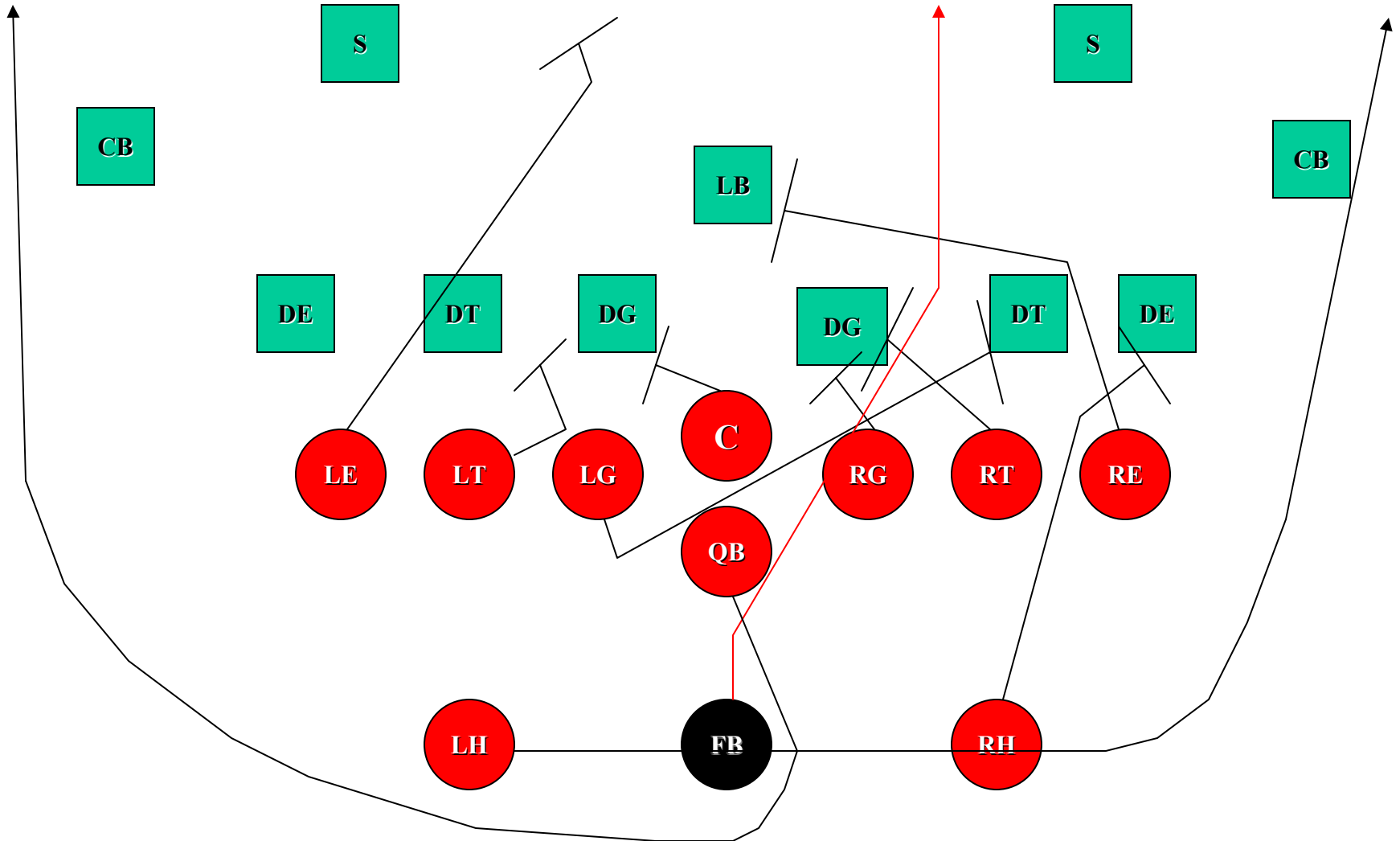

42 TRAP VS. 6-2 DEFENSE

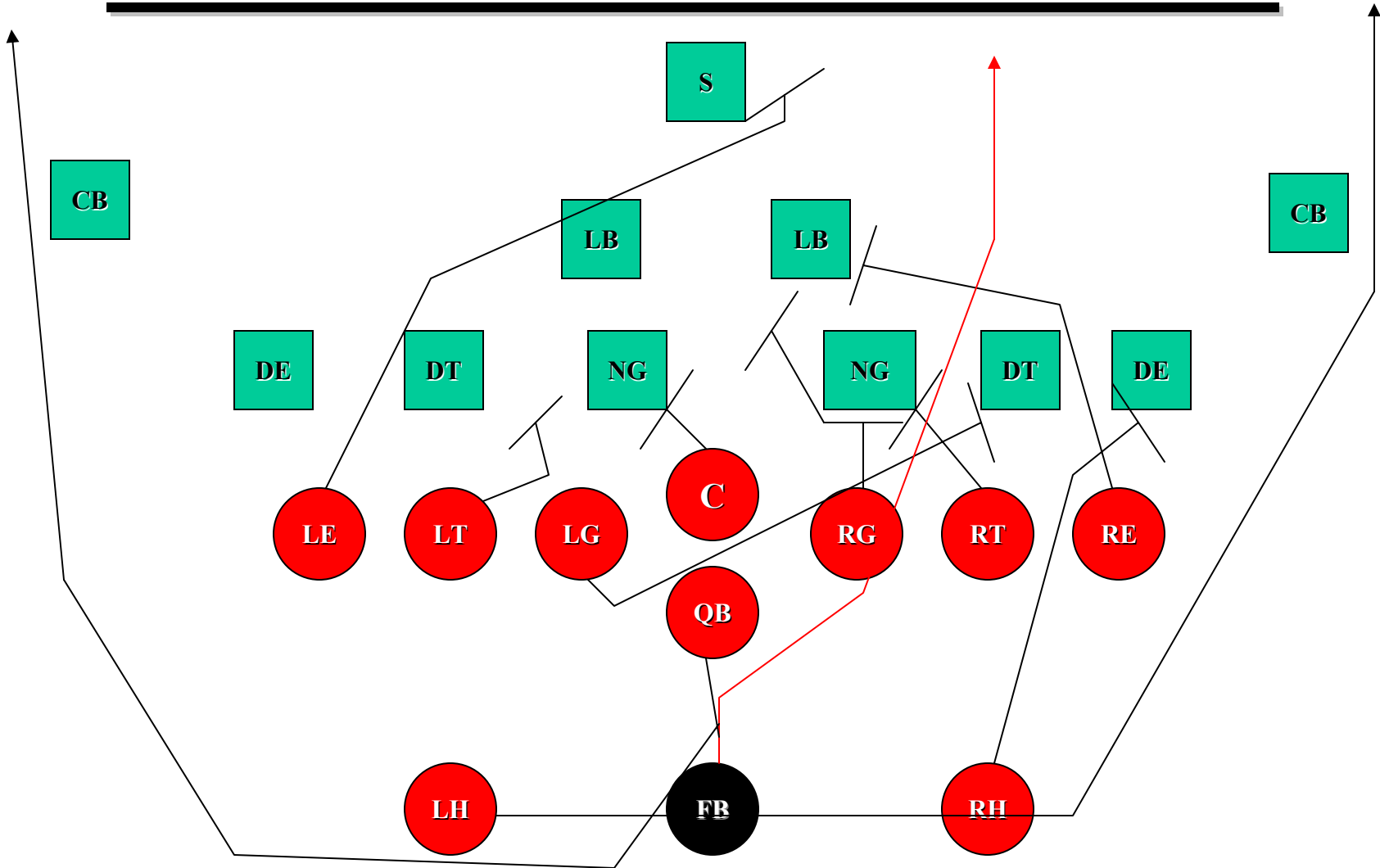

42 TRAP VS. 6-5 DEFENSE

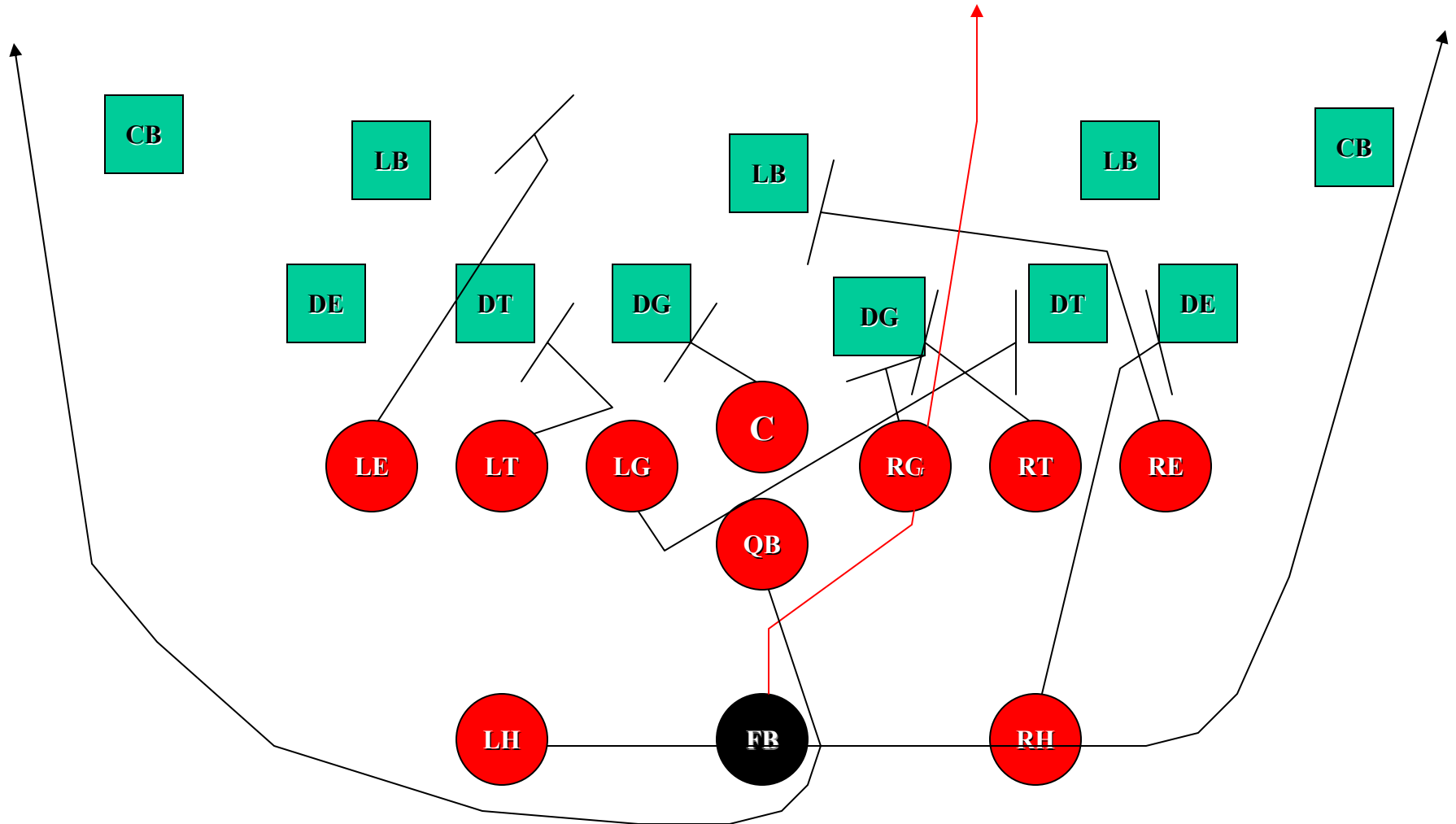

42 TRAP VS. 4-4 DEFENSE

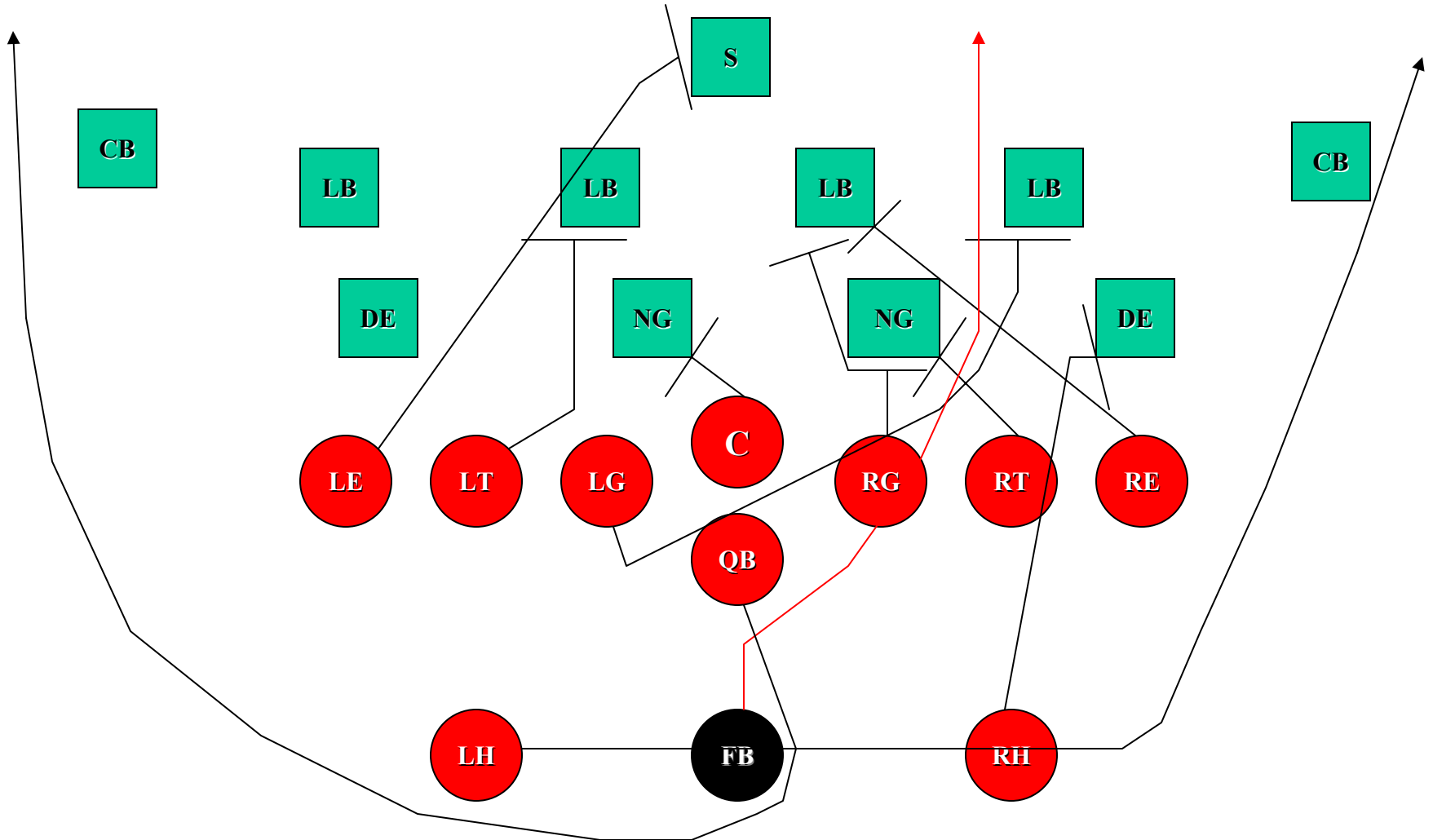

42 - 43 ICE RULES

TE:

FSE: BASE BLOCK THE D-END.
BLOCK 1ST MAN INSIDE VS. GAP
CALL.

BSE: BLOCK THE DEFENDER IN
THE MIDDLE THIRD OR HALF OF
THE FIELD.

T:

FST: BASE BLOCK VS. SPLIT
CALL. BLOCK DOWN ON 1ST MAN
INSIDE VS. GAP CALL.

BST: REACH PLAYSIDE AND
PROTECT INSIDE GAP.

G:

FSG: BASE BLOCK VS. SPLIT
CALL. BLOCK DOWN ON 1ST MAN
INSIDE VS. GAP CALL.

BSG: REACH PLAYSIDE AND
PROTECT INSIDE GAP.

C:

VS. ODD – BASE BLOCK A NG.

VS. EVEN – BLOCK THE MOST
DAGEROUS LB BACKSIDE.

QB:

PIVOT ON PLAYSIDE FOOT.
PUSH BALL BACK TO FB W/ONE
HAND. FAKE TO BSH AND THEN
FAKE BOOT BACKSIDE.

RUN OUTSIDE THE WIDEST
DEFENDER. SELL FAKE FOR 20
YARDS.

FB:

STEP FORWARD WITH PS FOOT.
RUN BETWEEN THE FSG & FST
BLOCK. READ FSH BLOCK ON LB.

STAY IN THE FUNEL AND KEEP
THE BALL WRAPPED UNTIL YOU
KNOW YOU CAN SCORE!

HB:

FSH: ISOLATE THE 1ST LB FROM
CENTER OUT VS. SPLIT CALL.
BLOCK 1ST UGLY SHIRT OUTSIDE
FSE VS. GAP CALL.

BSH: CROSS-OVER, POCKET
AND RUN OVER THE QB's HANDS.
RUN JUST OUTSIDE THE D-END.
SELL FAKE FOR 20 YARDS.



42 ICE VS 5-2 DEFENSE

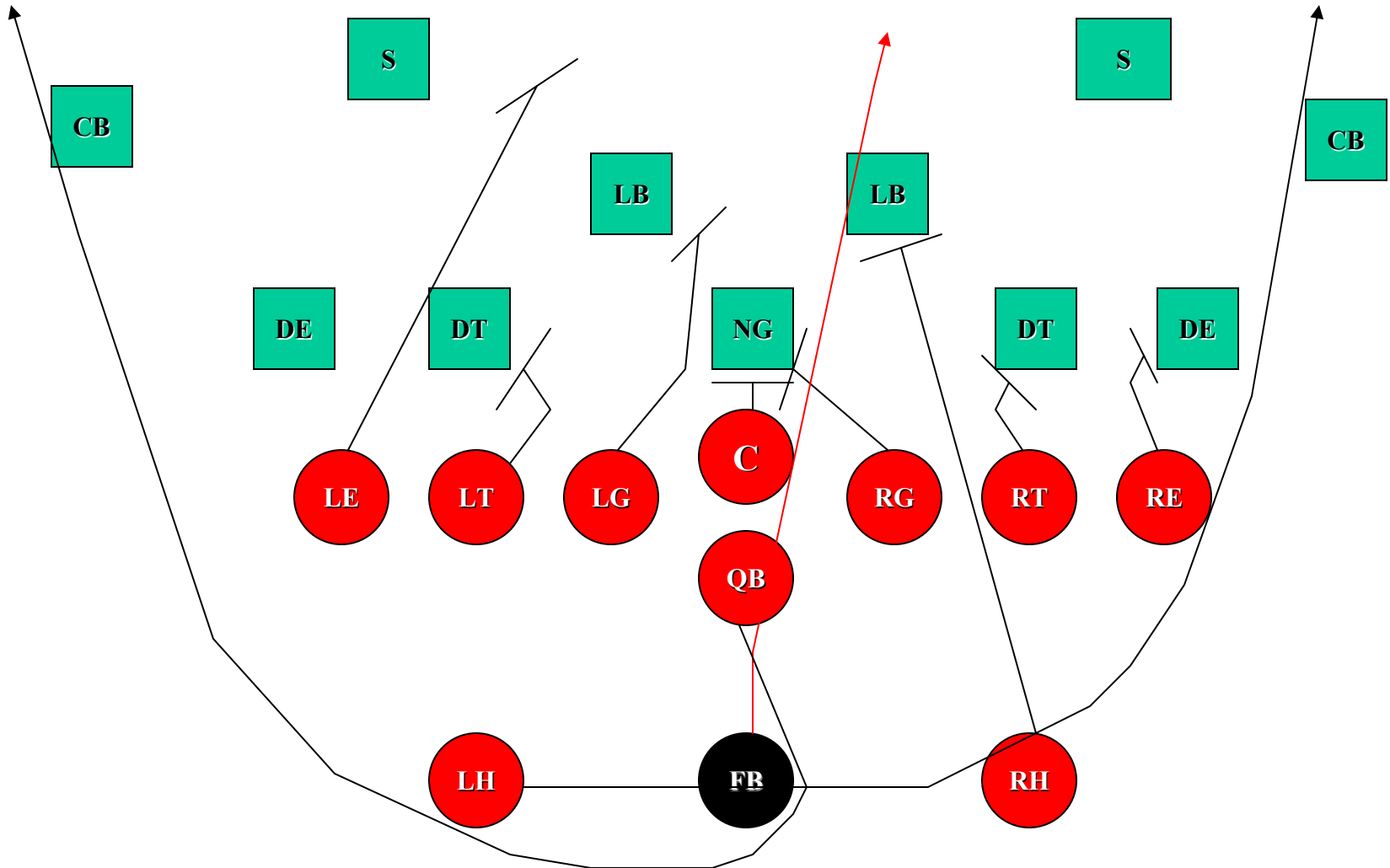

42 ICE VS. 5-3 DEFENSE

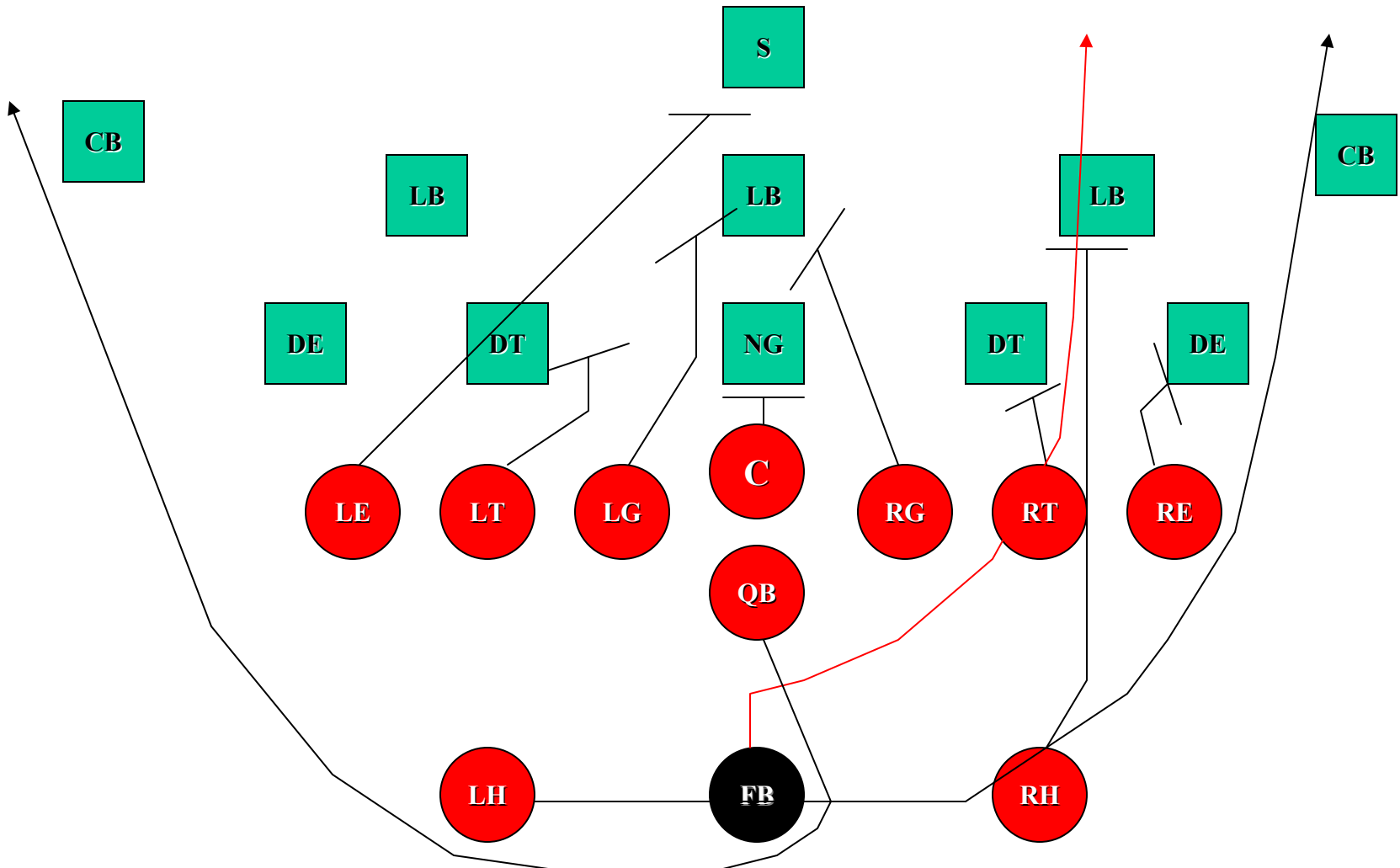

42 ICE VS. 7-1 DEFENSE

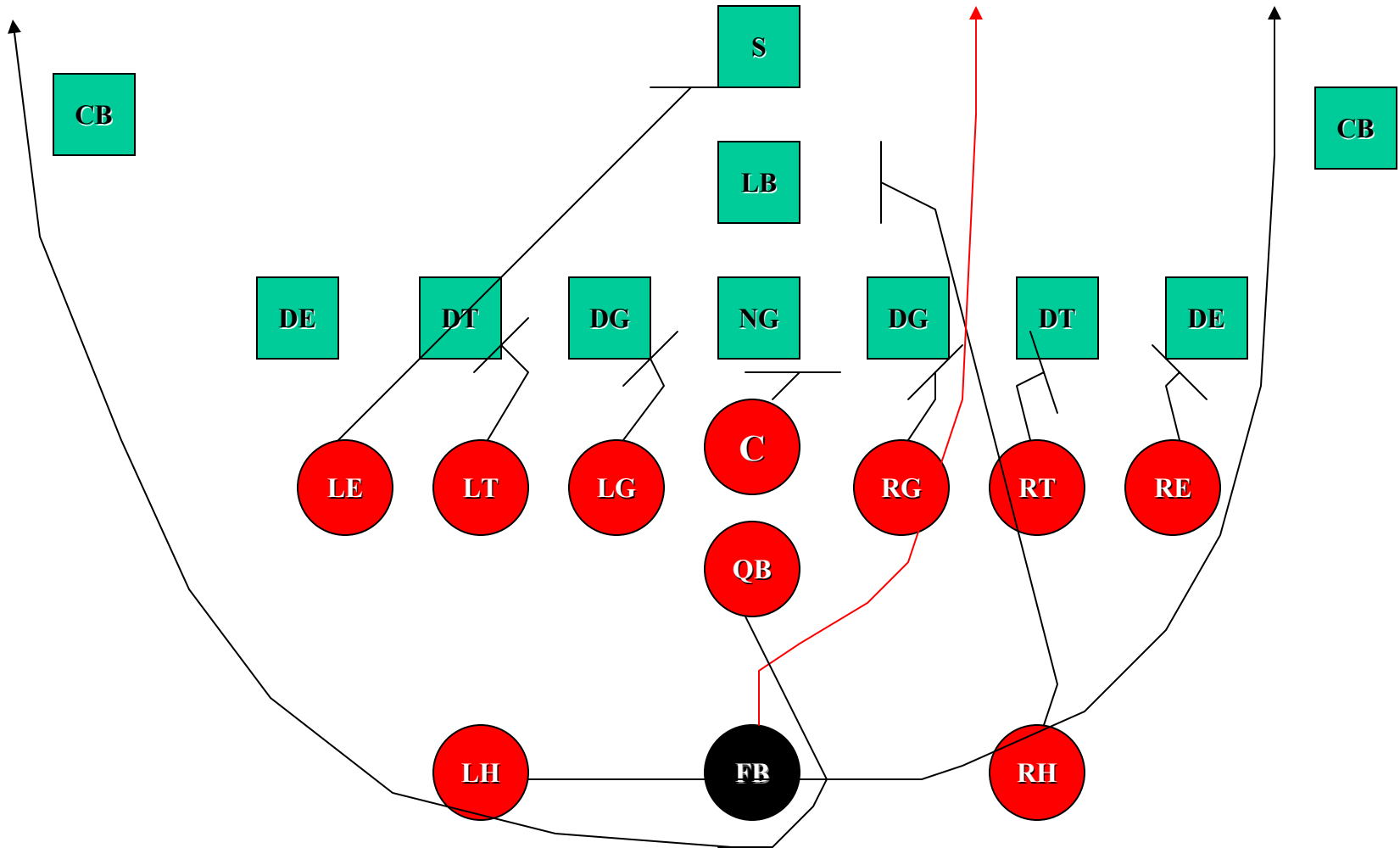

42 ICE VS. 6-1 DEFENSE

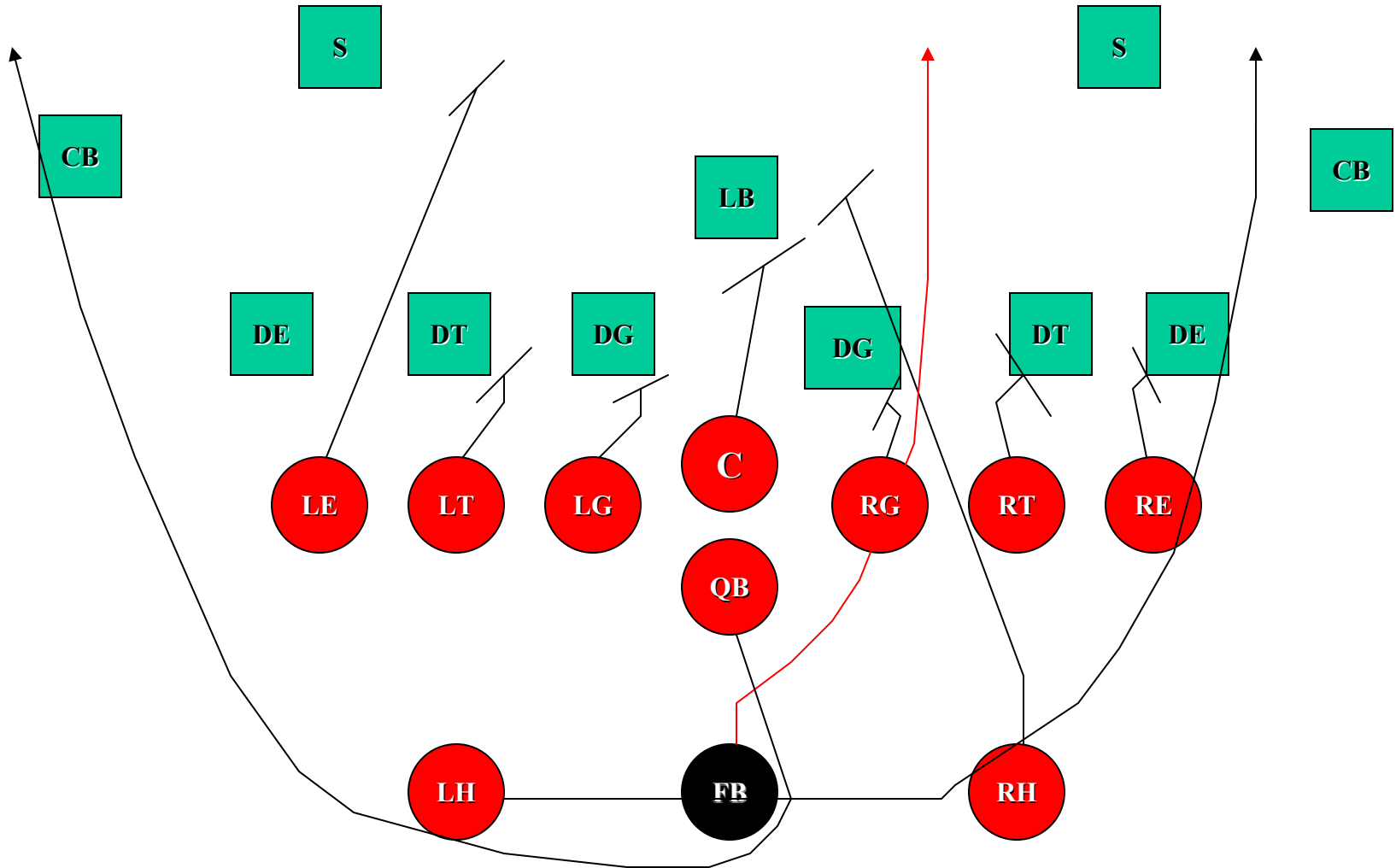

42 ICE VS. 6-2 DEFENSE

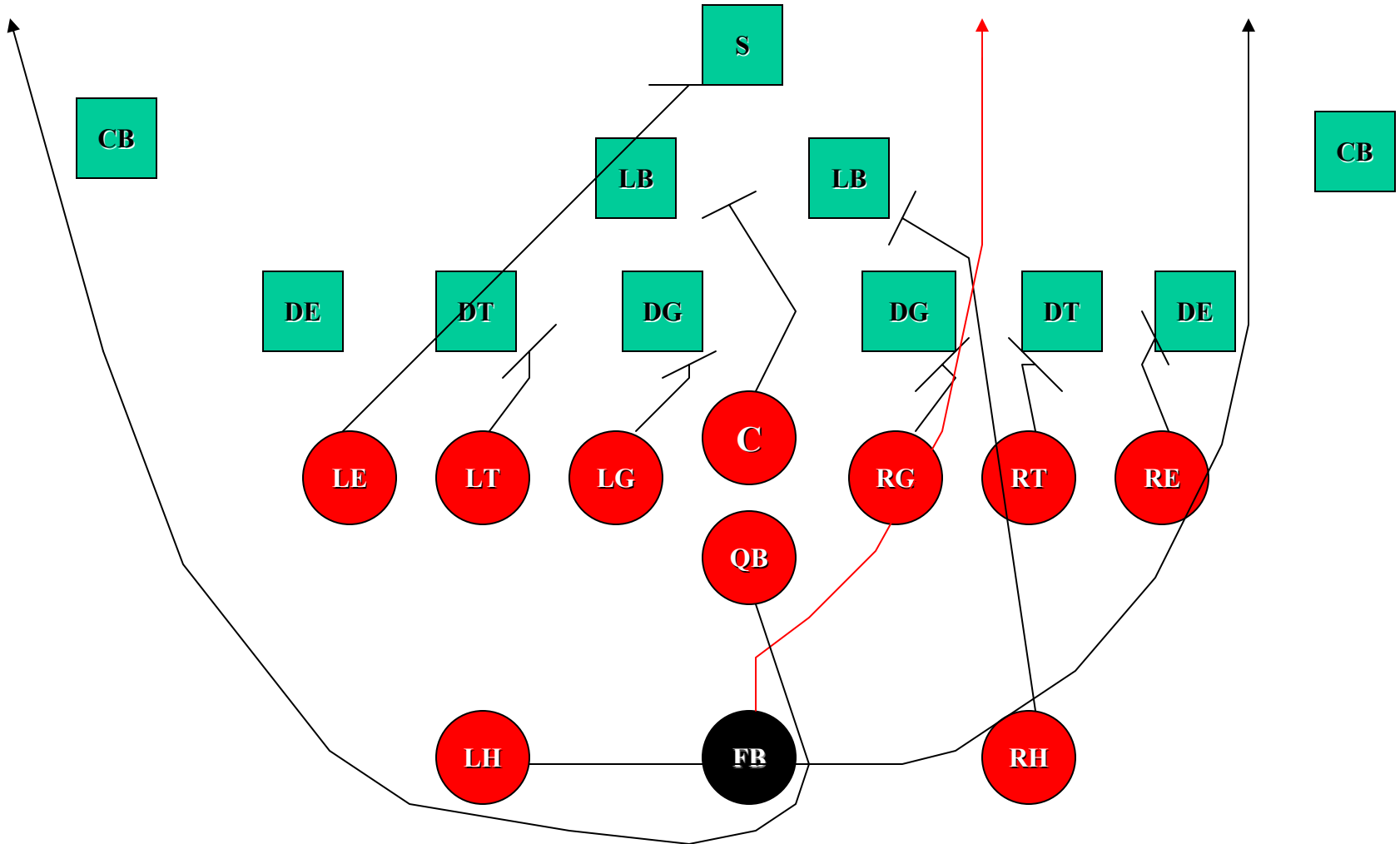

42 ICE VS. 6-5 DEFENSE

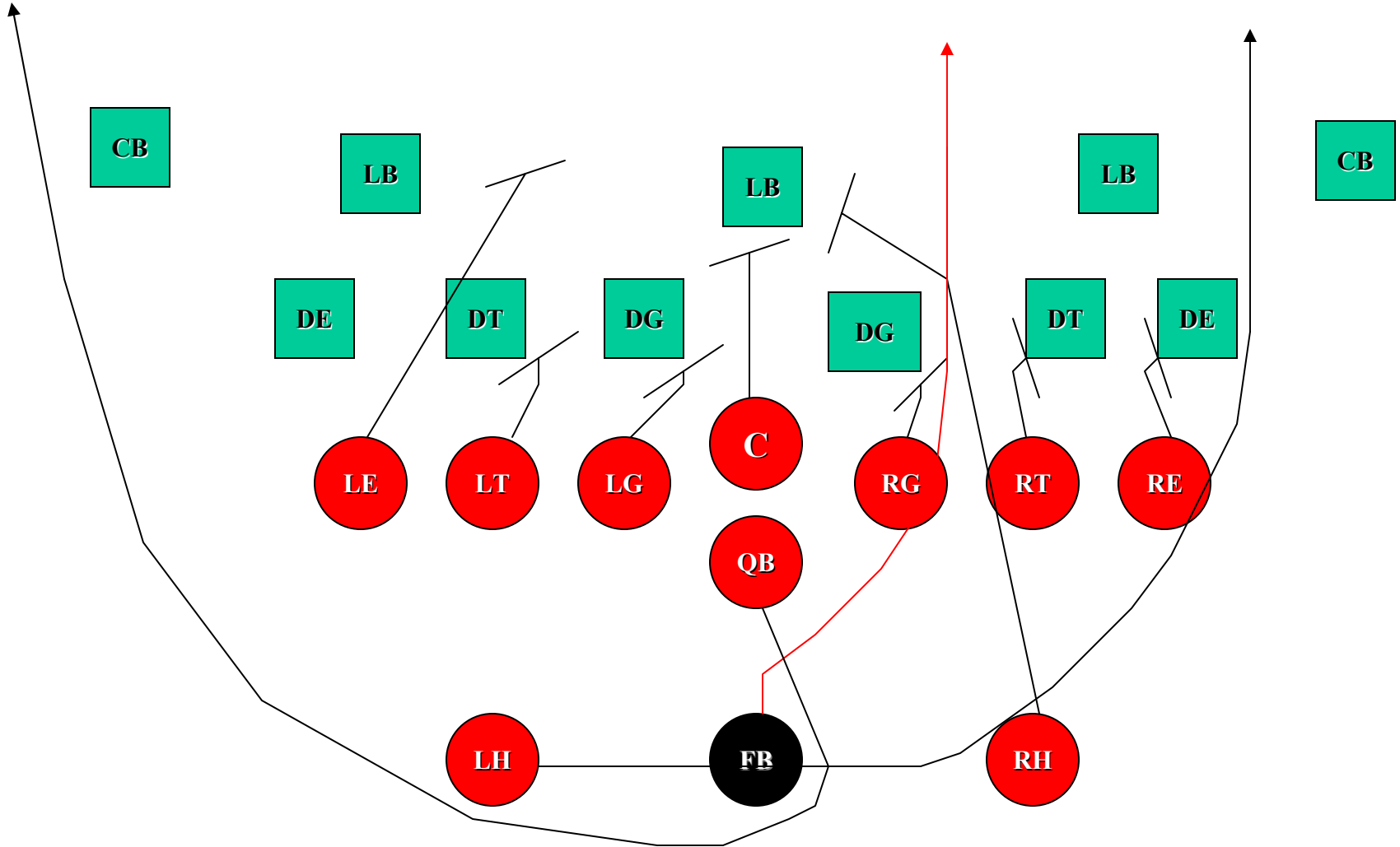

42 ICE VS. 4-3 DEFENSE

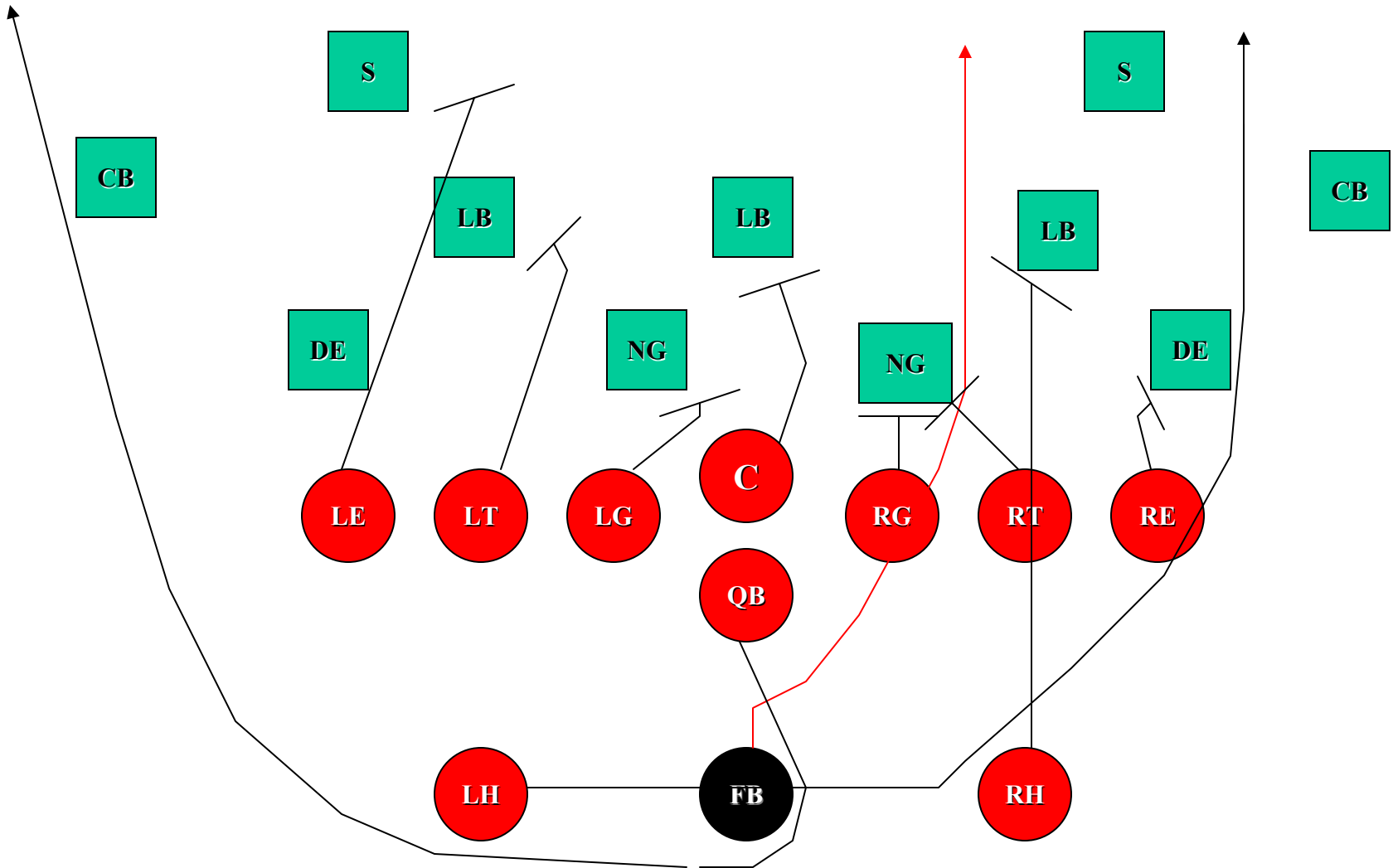

42 ICE VS. 4-4 DEFENSE

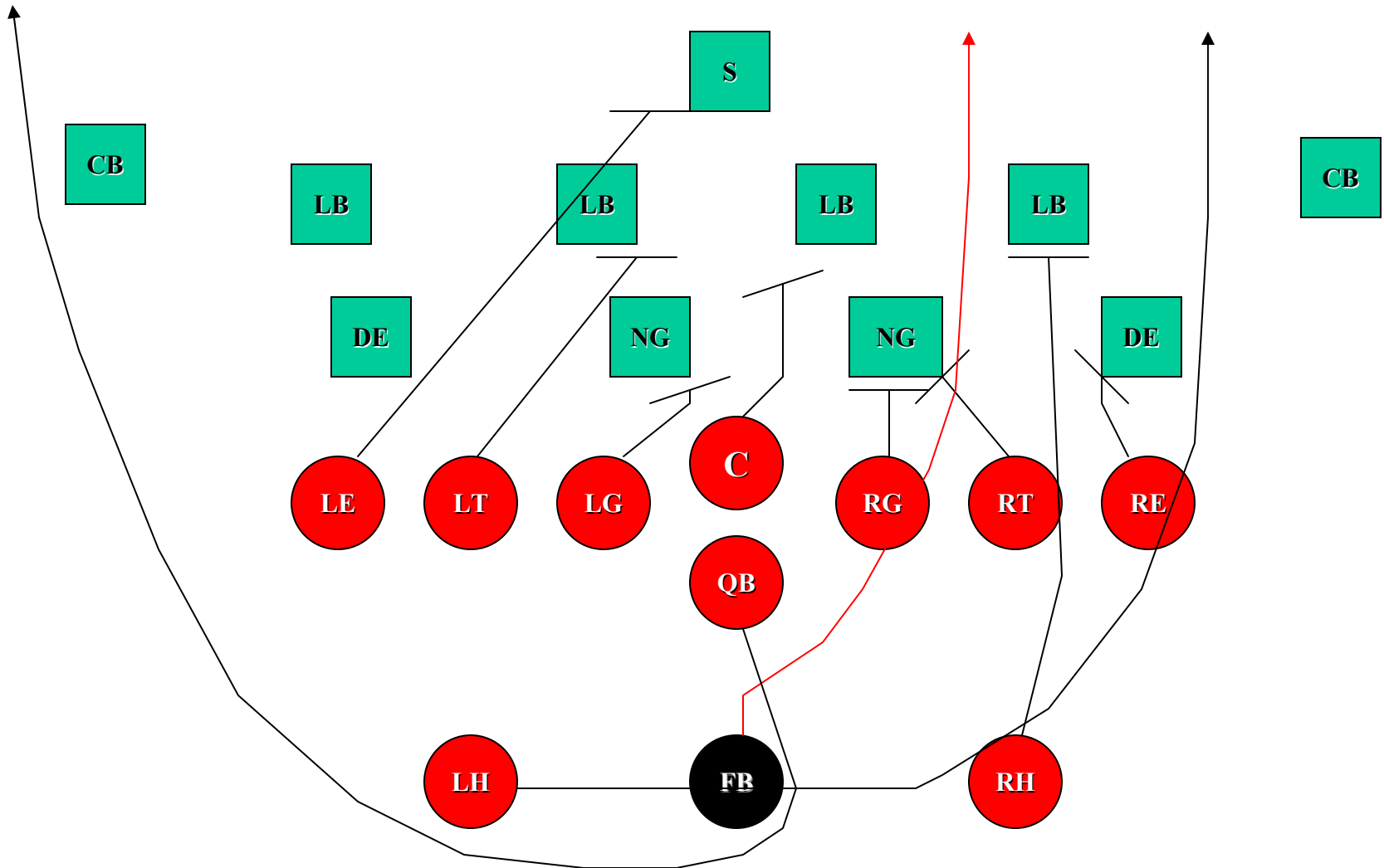

36 – 27 OFF-TACKLE RULES

TE:

FSE: BLOCK DOWN ON THE 1ST MAN INSIDE THE DEFENSIVE END. APPLY STACK RULES.

BSE: BLOCK THE DEFENDER IN THE MIDDLE THIRD OR HALF OF THE FIELD.

T:

FST: BLOCK THE 2ND MAN OUTSIDE THE CENTER. APPLY STACK RULES.

BST: ARC TO THE NEAR HIP OF THE MAN THE CENTER BLOCKS AND SEAL THE A-B GAP.

G:

FSG: BLOCK THE 1ST MAN OUTSIDE CENTER. APPLY STACK RULES.

BSG: PULL WITH A LEAD STEP AND ON YOUR 3RD STEP PUSH UP INTO THE OFF-TACKLE HOLE AND BLOCK 1ST UGLY SHIRT.

C:

VS. ODD – BLOCK NG. BLOCK A 1 TECHNIQUE IF ABLE. OR IDENTIFY HIM AS #1

VS. EVEN – BLOCK MOST DANGEROUS SHIRT BACKSIDE.

QB:

PIVOT ON PLAYSIDE FOOT AND CLEAR MID-LINE. PUSH BALL BACK TO BSH ON 2ND STEP. THEN FAKE KEEP OUT PLAYSIDE.

RUN OUTSIDE THE WIDEST DEFENDER. SELL FAKE FOR 20 YARDS.

FB:

STEP FORWARD WITH PS FOOT AND MAKE A PROXIMITY FAKE W/QB. POCKET AND ROCK THE CRADLE.

RUN INTO THE FRONT SIDE B-GAP LOOKING FOR AN UGLY SHIRT TO BLOCK.

HB:

FSH: J-BLOCK THE DEFENSIVE END ON THE INSIDE NUMBER AND KEEP HIM WHERE HE'S AT OR PUSH HIM OUTSIDE.

BSH: CROSS-OVER, POCKET AND ON YOUR NEXT STEP PUSH UP FIELD. BE AT THE LINE BY 4TH STEP. KEEP BALL LAYERED UNTIL YOU CAN SCORE!



36 VS. 5-2 DEFENSE

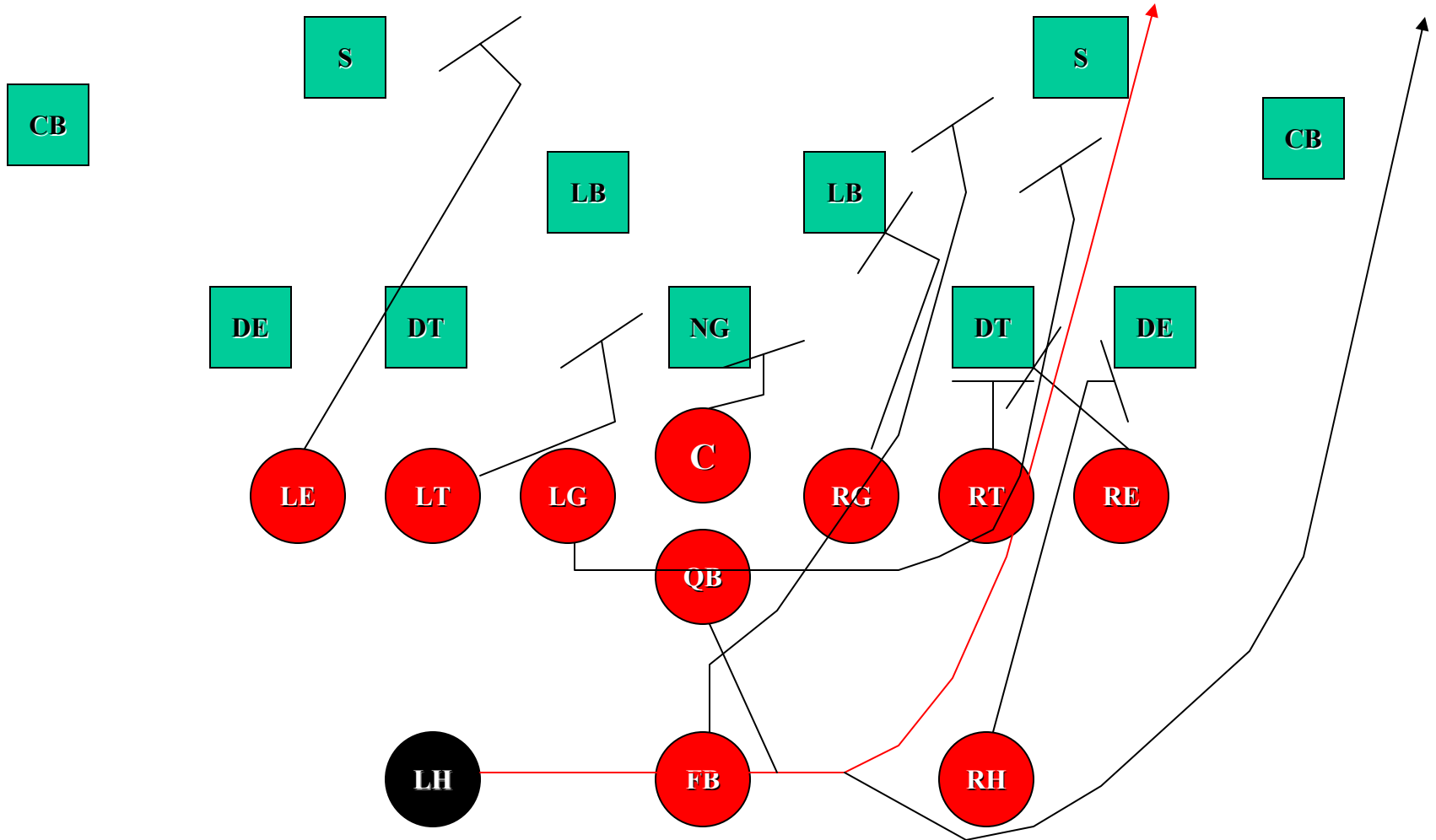

36 VS. 5-3 DEFENSE

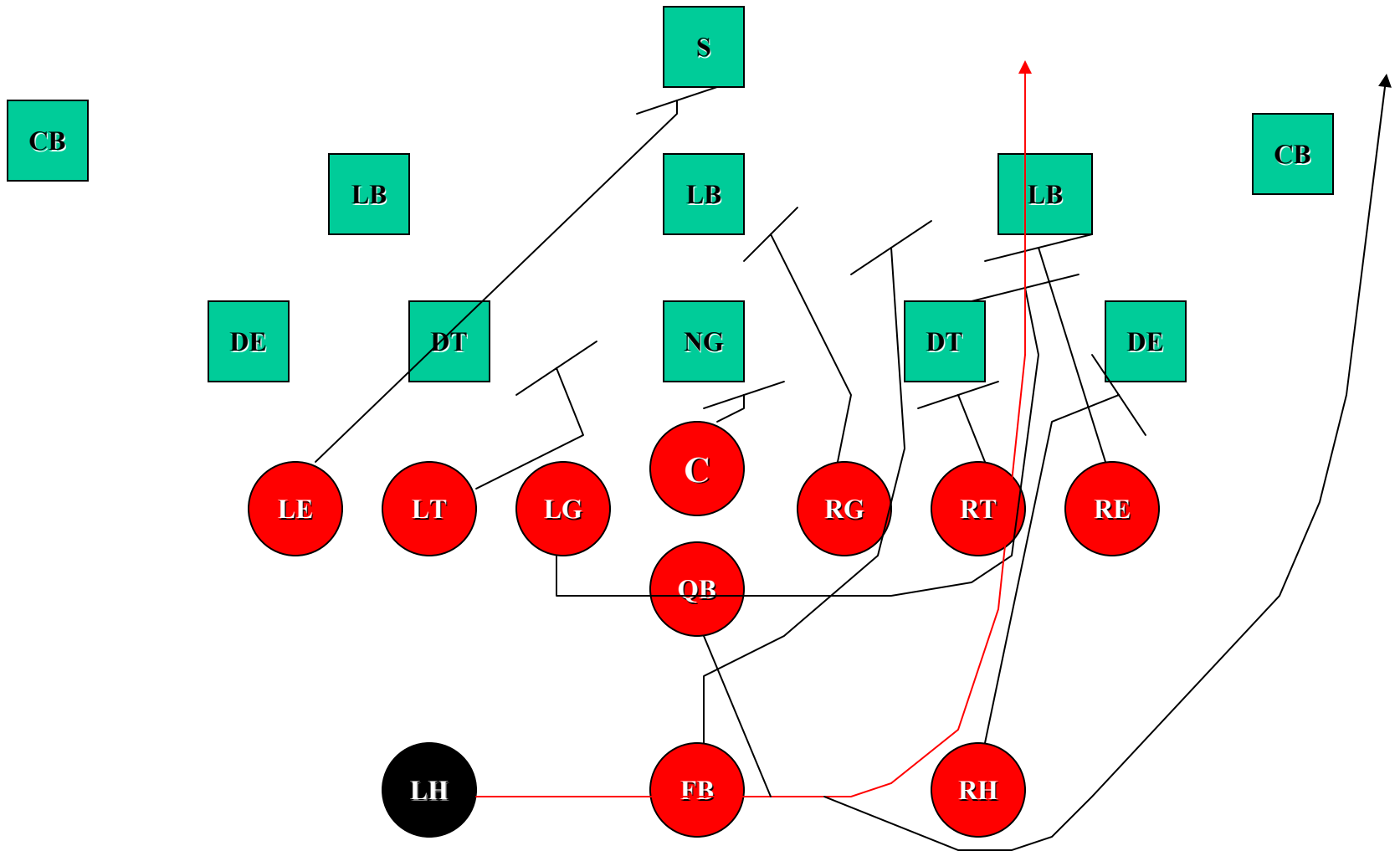

36 VS. 7-1 DEFENSE

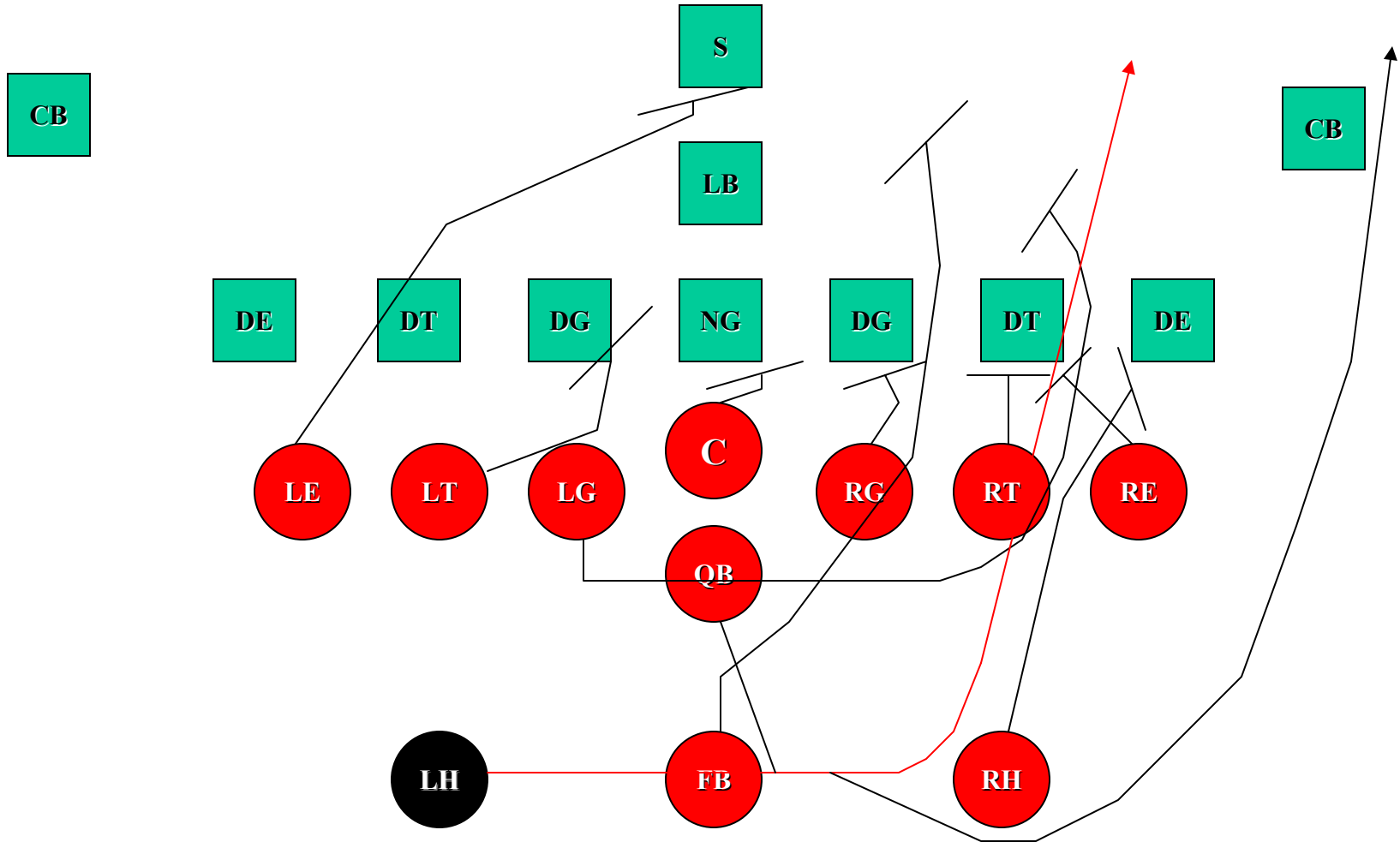

36 VS. 6-1 DEFENSE

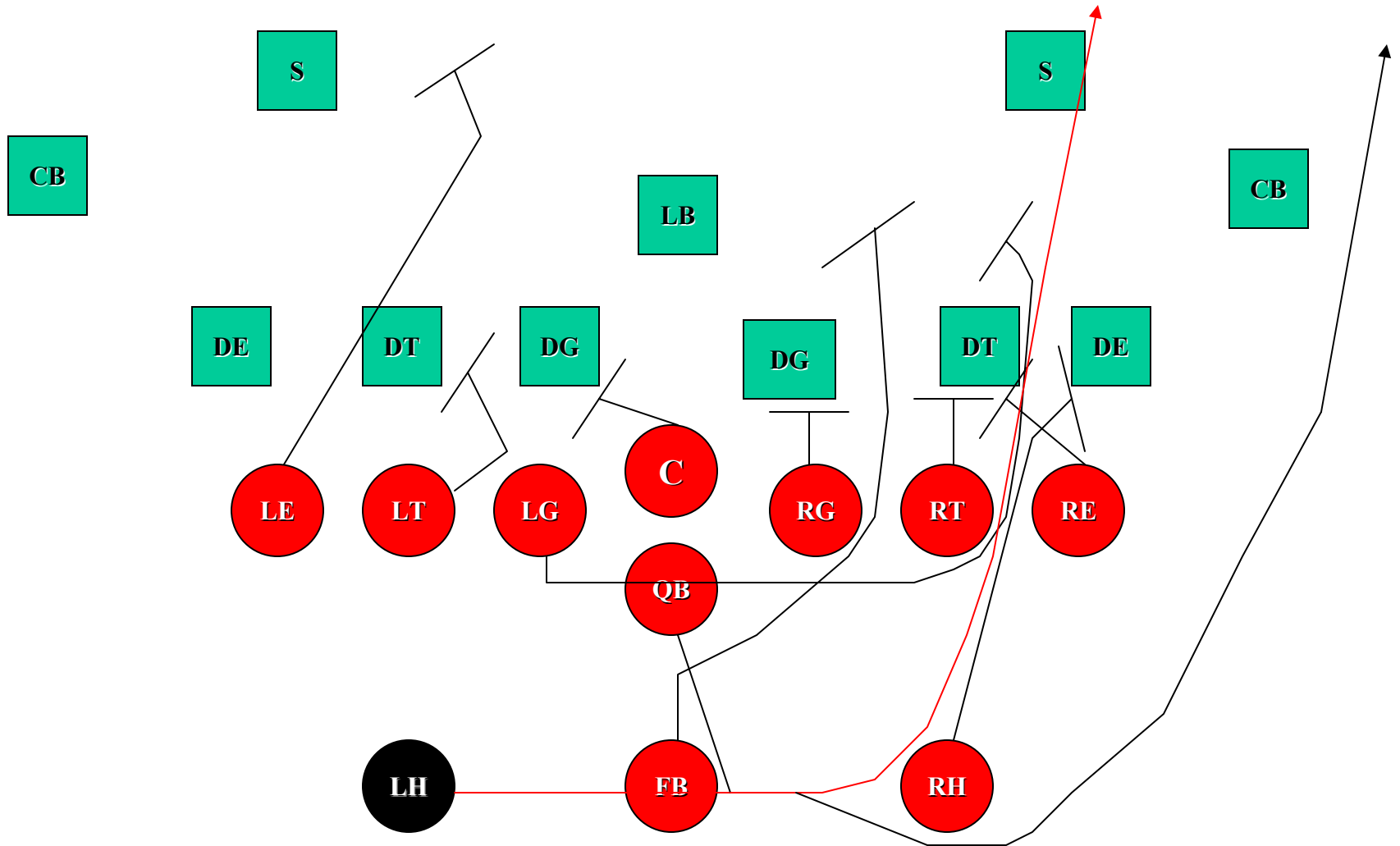

36 VS. 6-2 DEFENSE

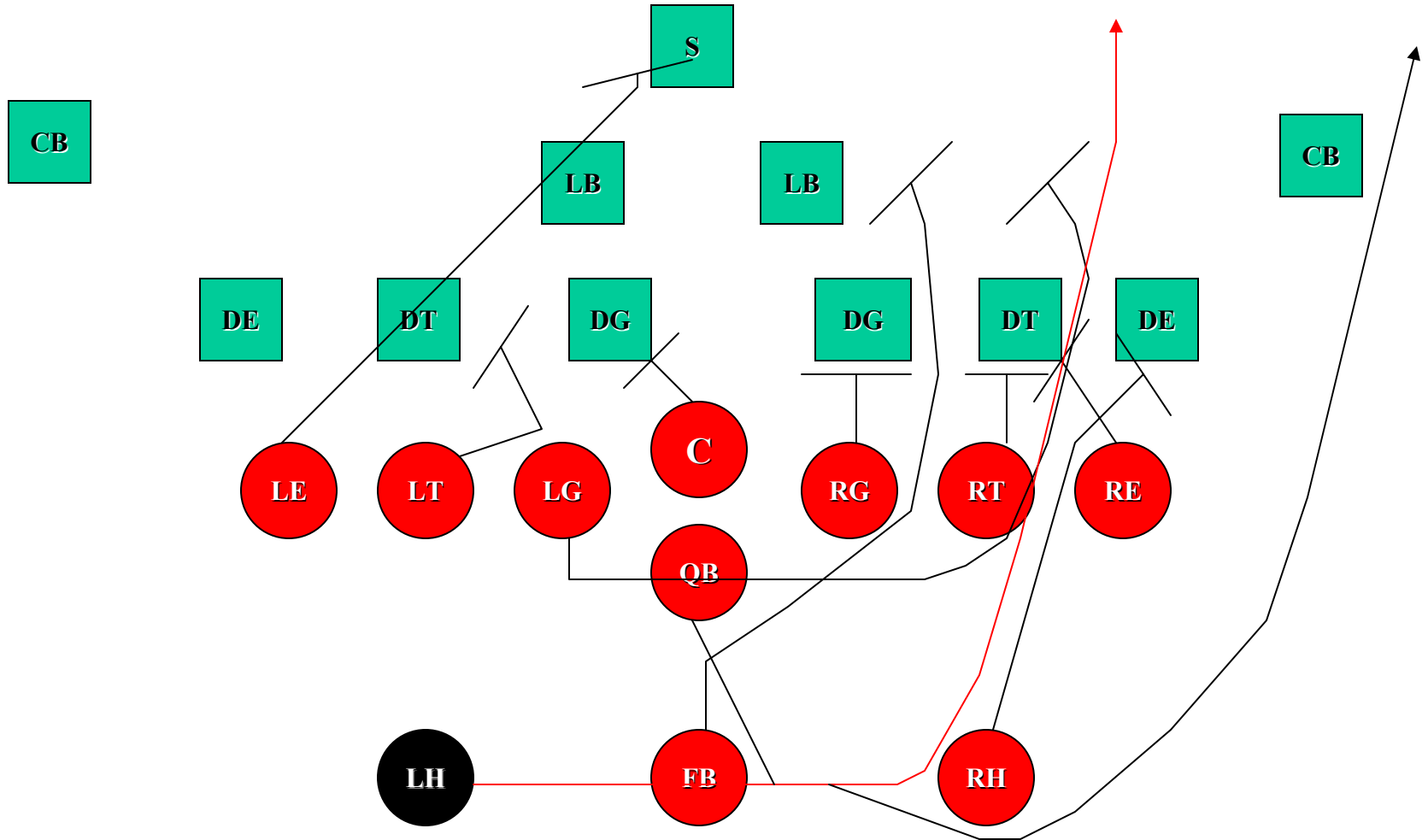

36 VS. 6-5 DEFENSE

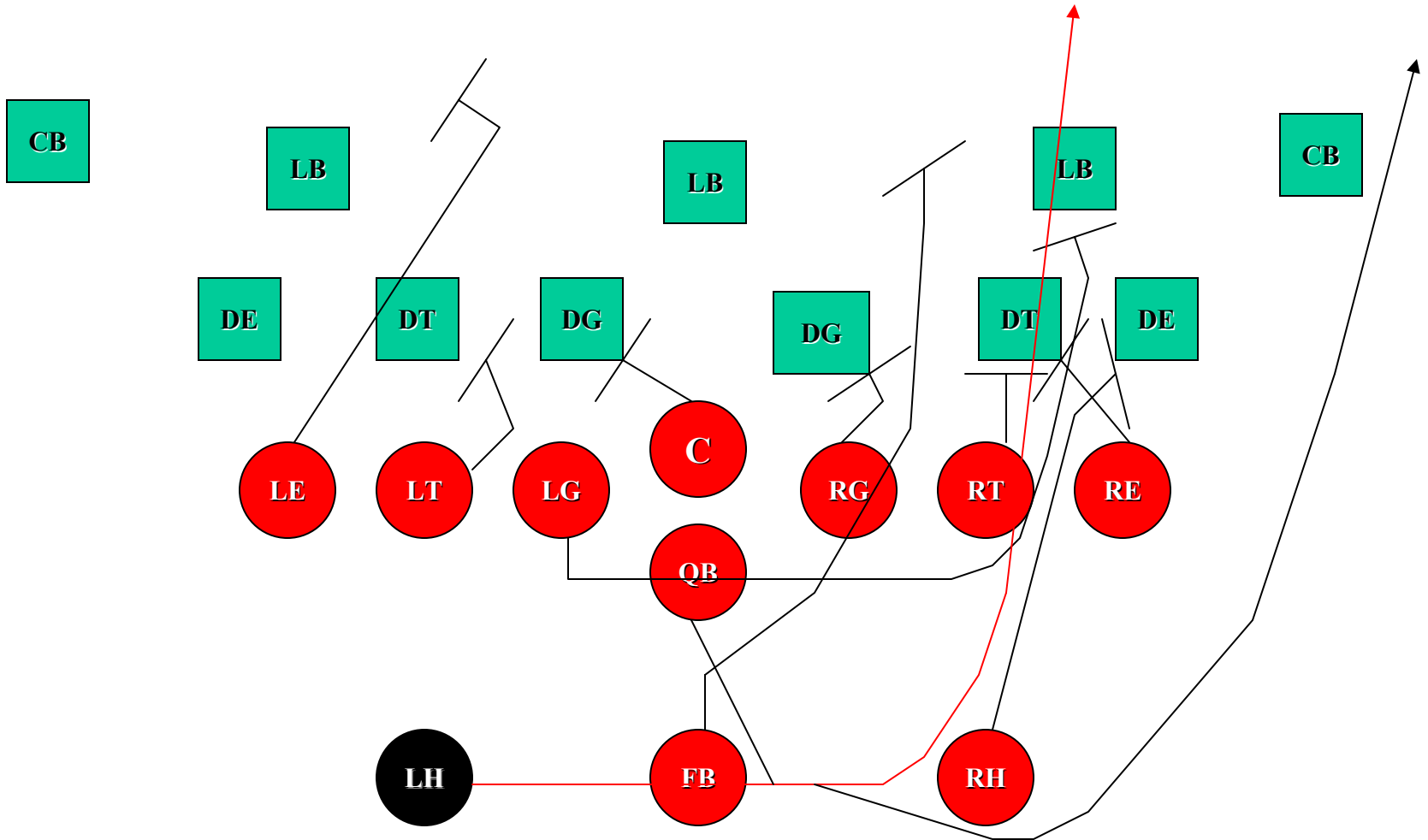

36 VS. 4-3 DEFENSE

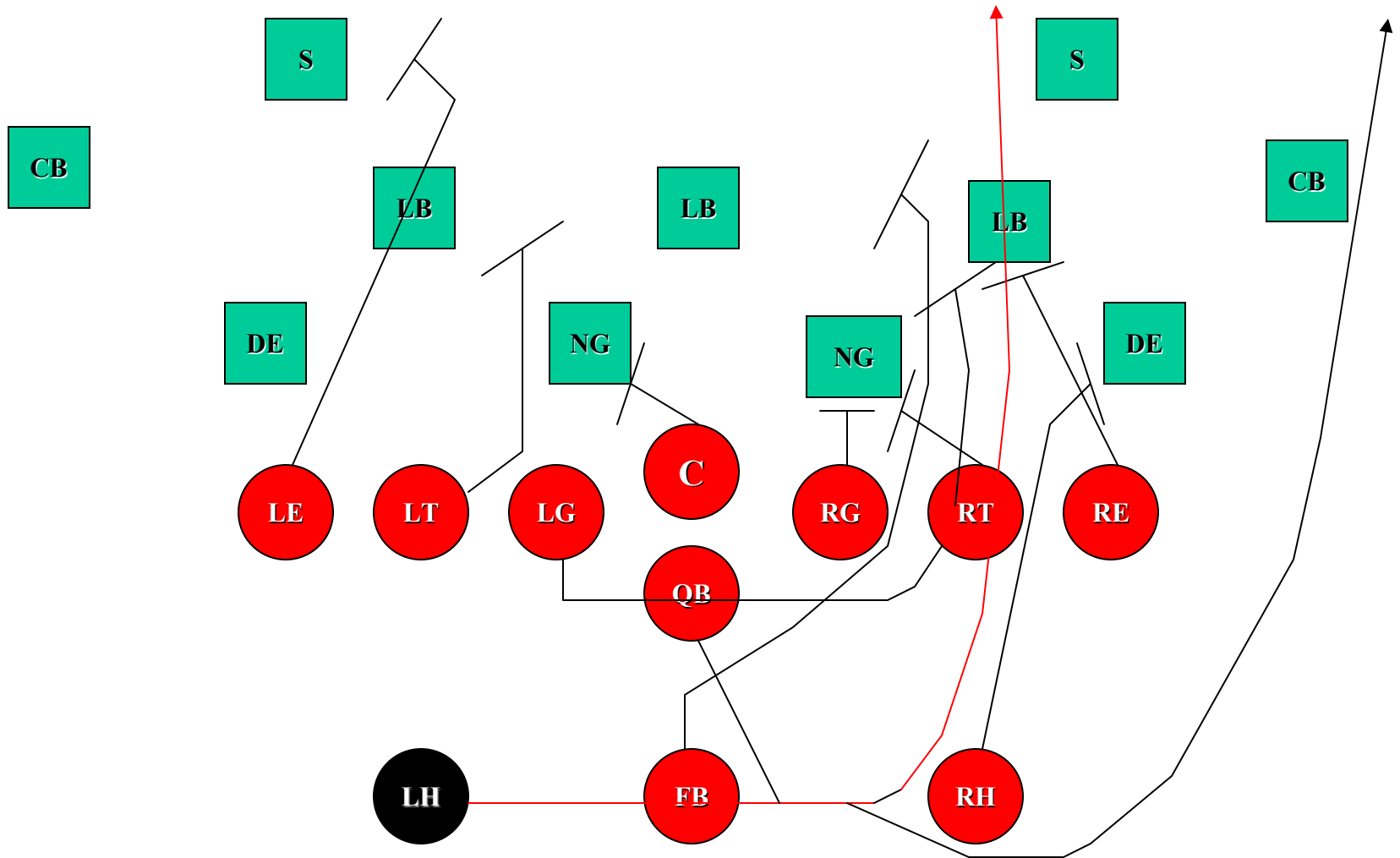

36 VS. 4-4 DEFENSE

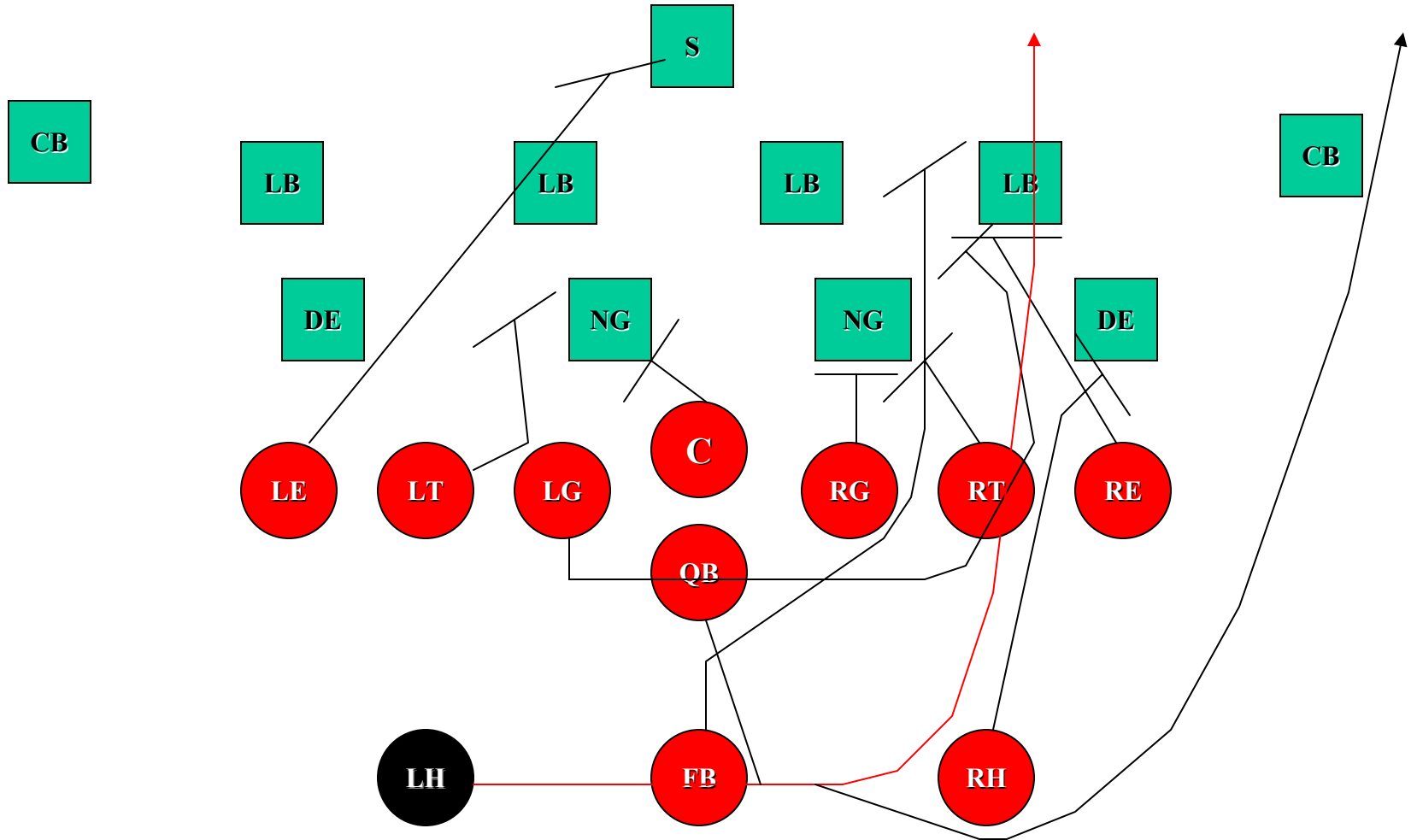

36 - 27 ADJUSTMENTS



36 – 27 SWITCH RULES

TE:

FSE: BLOCK OUT ON THE DEFENSIVE END. KEEP HIM WHERE HE'S AT OR PUSH HIM OUTSIDE

BSE: BLOCK THE DEFENDER IN THE MIDDLE THIRD OR HALF OF THE FIELD.

T:

FST: BLOCK THE 2ND MAN OUTSIDE THE CENTER. APPLY STACK RULES.

BST: ARC TO THE NEAR HIP OF THE MAN THE CENTER BLOCKS AND SEAL THE A-B GAP.

G:

FSG: BLOCK THE 1ST MAN OUTSIDE CENTER. APPLY STACK RULES.

BSG: PULL WITH A LEAD STEP AND ON YOUR 3RD STEP PUSH UP INTO THE OFF-TACKLE HOLE AND BLOCK 1ST UGLY SHIRT.

C:

VS. ODD – BLOCK NG. BLOCK A 1TECHNIQUE IF ABLE. OR IDENTIFY HIM AS #1

VS. EVEN – BLOCK MOST DANGEROUS SHIRT BACKSIDE.

QB:

PIVOT ON PLAYSIDE FOOT AND CLEAR MID-LINE. PUSH BALL BACK TO BSH ON 2ND STEP. THEN FAKE KEEP OUT PLAYSIDE.

RUN OUTSIDE THE WIDEST DEFENDER. SELL FAKE FOR 20 YARDS.

FB:

STEP FORWARD WITH PS FOOT AND MAKE A PROXIMITY FAKE W/QB. POCKET AND ROCK THE CRADLE.

RUN INTO THE FRONT SIDE B-GAP LOOKING FOR AN UGLY SHIRT TO BLOCK.

HB:

FSH: BLOCK THE 1ST MAN INSIDE THE DEFENSIVE END. APPLY STACK RULES.

BSH: CROSS-OVER, POCKET AND ON YOUR NEXT STEP PUSH UP FIELD. BE AT THE LINE BY 4TH STEP. KEEP BALL LAYERED UNTIL YOU CAN SCORE!

36 SWITCH VS. 5-3

DEFENSE

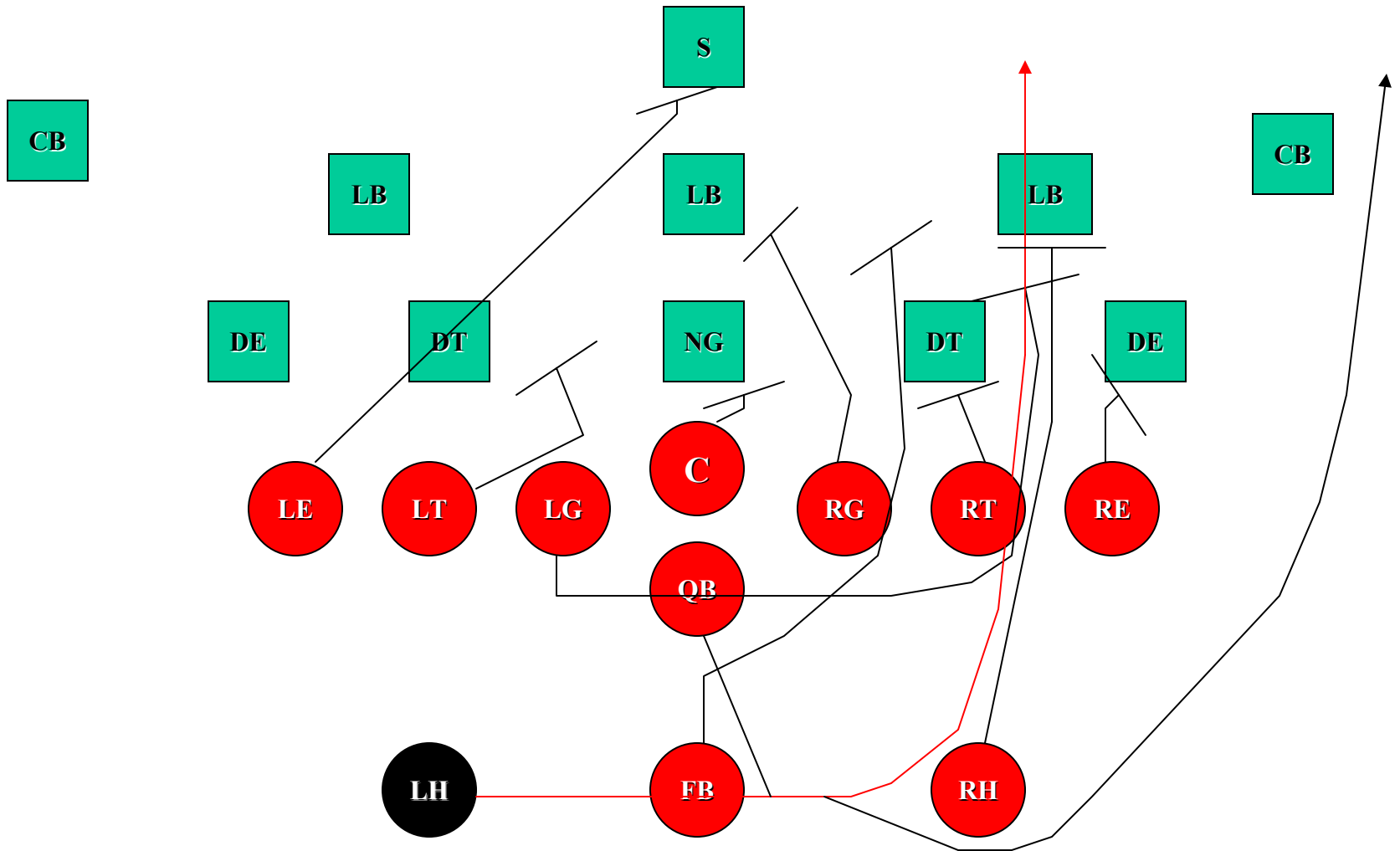

36 SWITCH VS. 4-4

DEFENSE

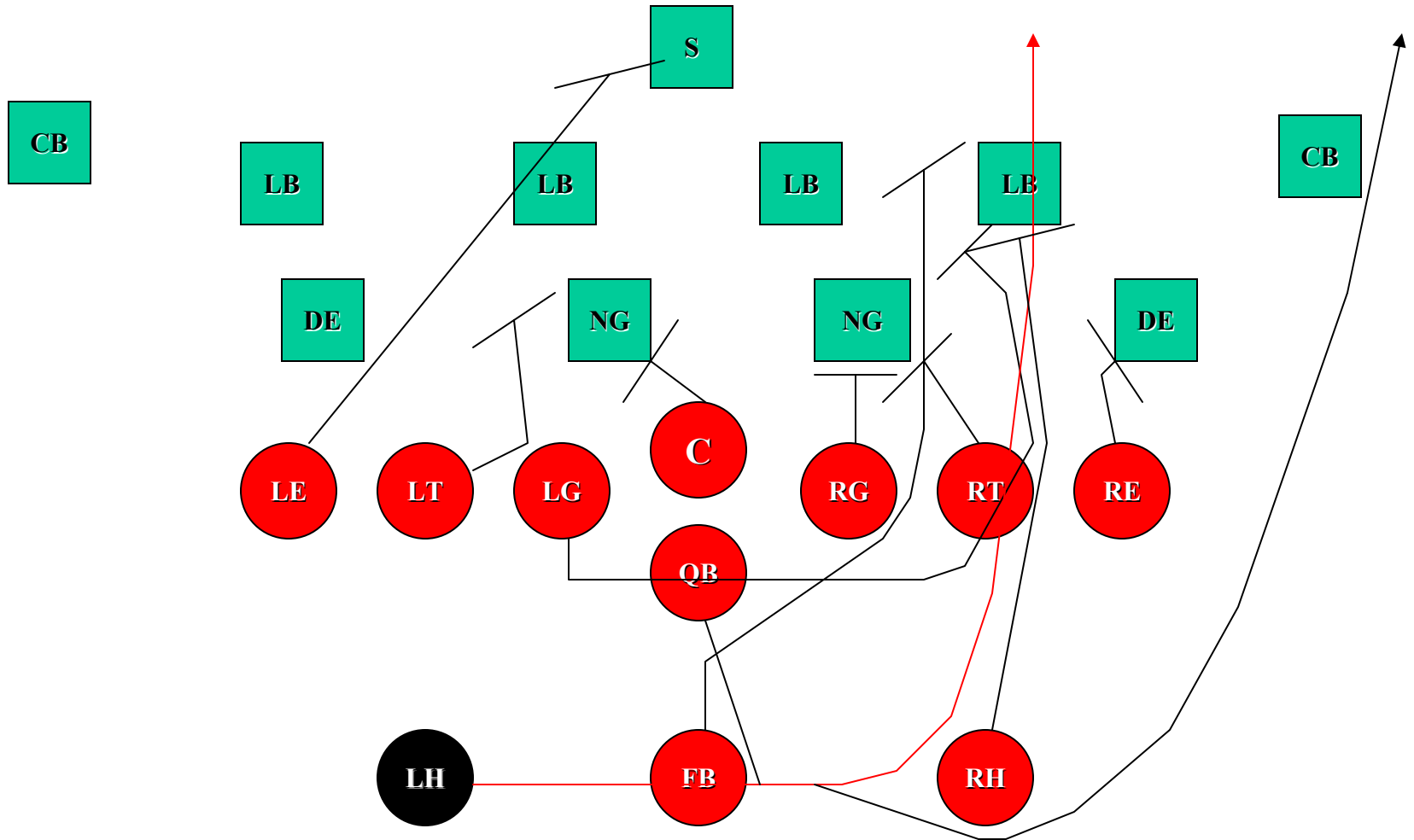

36 – 27 TRAP RULES

TE:

FSE: BLOCK DOWN ON THE 1ST MAN INSIDE THE DEFENSIVE END. APPLY STACK RULES.

BSE: BLOCK THE DEFENDER IN THE MIDDLE THIRD OR HALF OF THE FIELD.

T:

FST: BLOCK THE 2ND MAN OUTSIDE THE CENTER. APPLY STACK RULES.

BST: ARC TO THE NEAR HIP OF THE MAN THE CENTER BLOCKS AND SEAL THE A-B GAP.

G:

FSG: BLOCK THE 1ST MAN OUTSIDE CENTER. APPLY STACK RULES.

BSG: PULL AND TRAP 1ST UGLY SHIRT PAST THE FSE'S DOWN BLOCK.

C:

VS. ODD – BLOCK NG. BLOCK A 1TECHNIQUE IF ABLE. OR IDENTIFY HIM AS #1

VS. EVEN – BLOCK MOST DANGEROUS SHIRT BACKSIDE.

QB:

PIVOT ON PLAYSIDE FOOT AND CLEAR MID-LINE. PUSH BALL BACK TO BSH ON 2ND STEP. THEN FAKE KEEP OUT PLAYSIDE.

RUN OUTSIDE THE WIDEST DEFENDER. SELL FAKE FOR 20 YARDS.

FB:

STEP FORWARD WITH PS FOOT AND MAKE A PROXIMITY FAKE W/QB. POCKET AND ROCK THE CRADLE.

RUN INTO THE FRONT SIDE B-GAP LOOKING FOR AN UGLY SHIRT TO BLOCK.

HB:

FSH: FROM WING BLOCK DOWN ON THE 1ST LB INSIDE. FROM T BLOCK FIRST UGLY SHIRT PAST C-GAP.

BSH: CROSS-OVER, POCKET AND ON YOUR NEXT STEP PUSH UP FIELD. BE AT THE LINE BY 4TH STEP. KEEP BALL LAYERED UNTIL YOU CAN SCORE!

236 TRAP VS. 7-1 DEFENSE

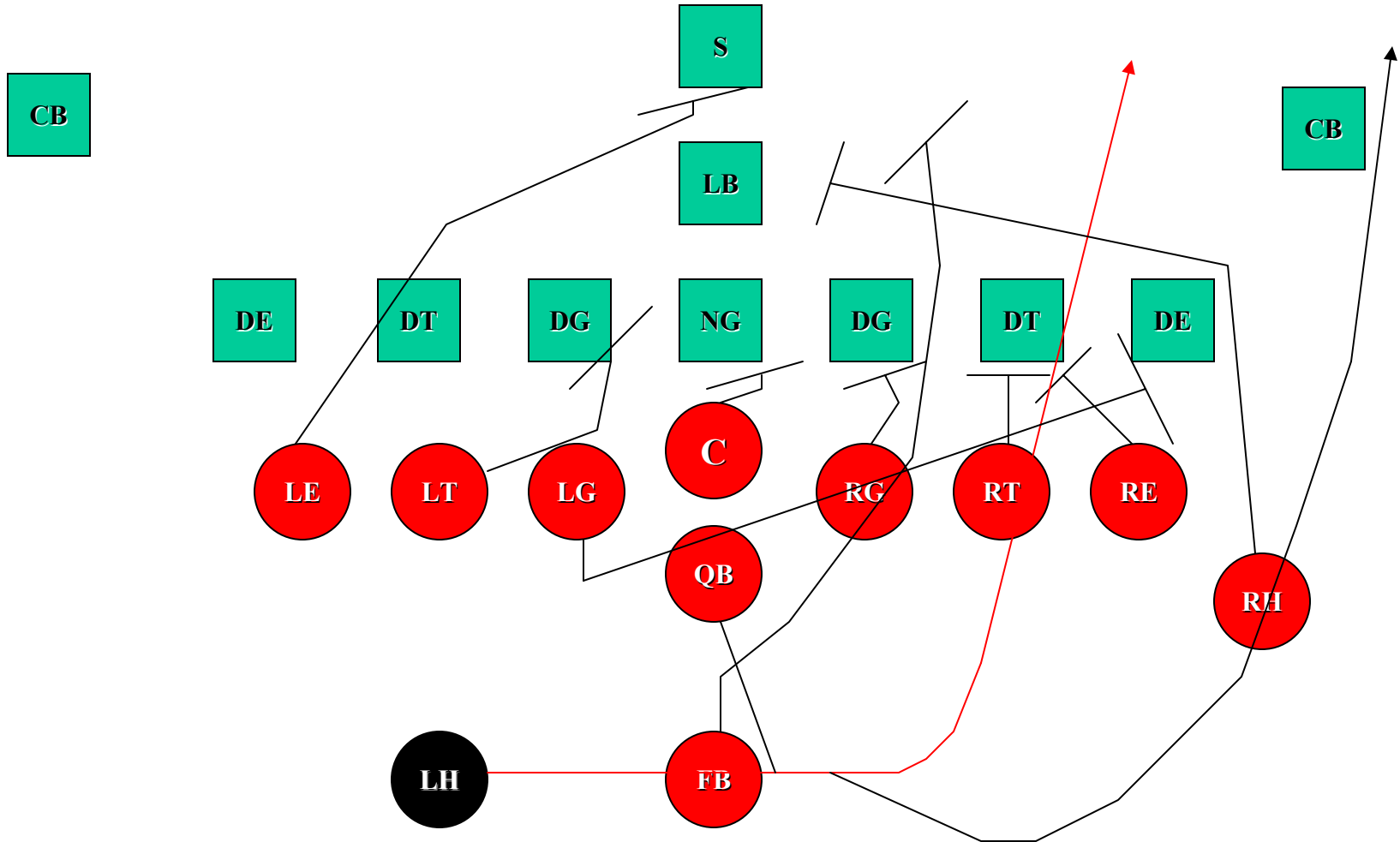

236 TRAP VS. 4-3 DEFENSE

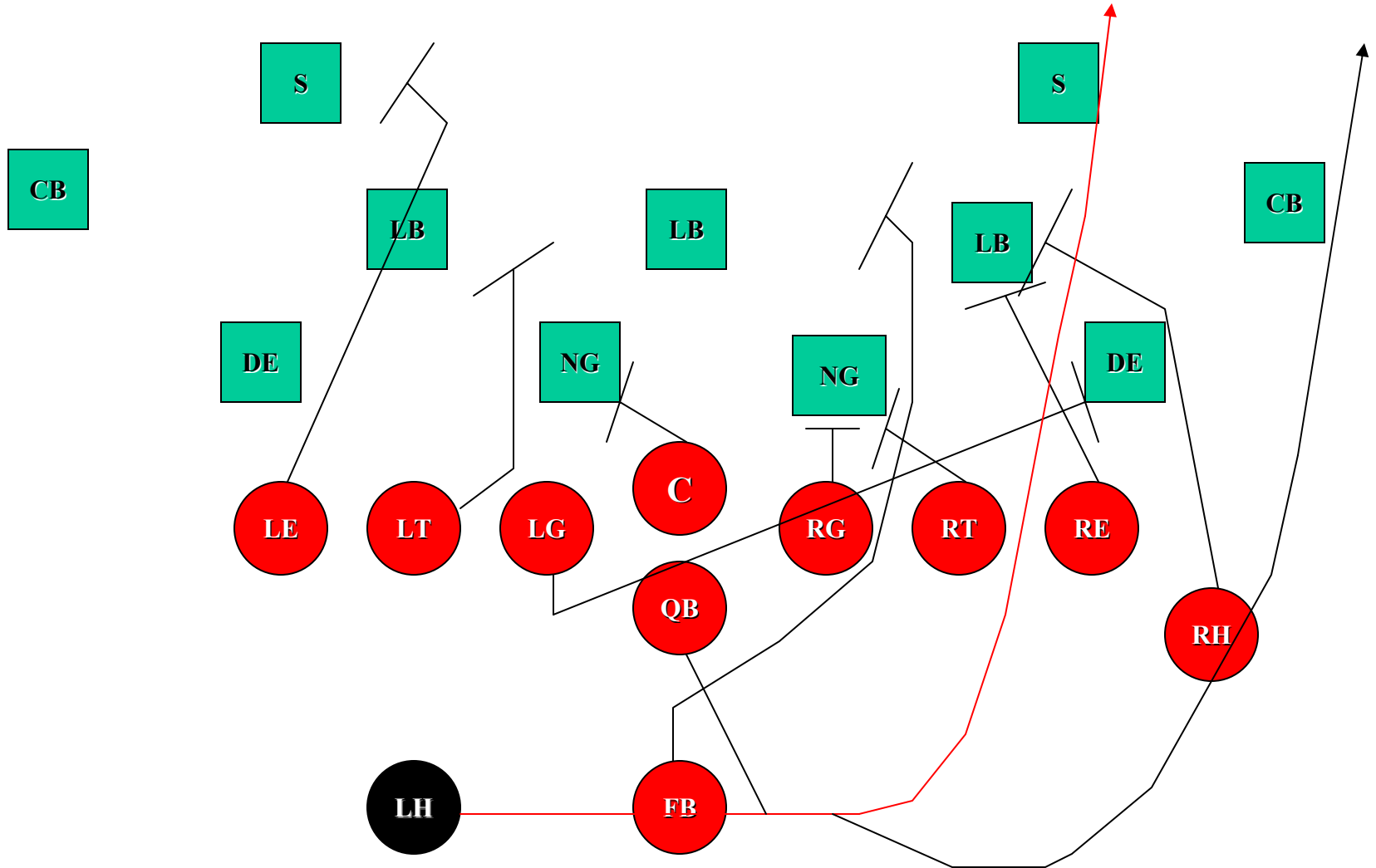

36 – 27 POWER RULES

TE:	FSE: BLOCK DOWN ON THE 1 ST MAN INSIDE THE DEFENSIVE END. APPLY STACK RULES.	BSE: BLOCK THE DEFENDER IN THE MIDDLE THIRD OR HALF OF THE FIELD.
T:	FST: BLOCK THE 2ND MAN OUTSIDE THE CENTER. APPLY STACK RULES.	BST: REACH PLAYSIDE AND PROTECT INSIDE GAP.
G:	FSG: BLOCK THE 1 ST MAN OUTSIDE CENTER. APPLY STACK RULES.	BSG: REACH PLAYSIDE AND PROTECT INSIDE GAP.
C:	VS. ODD – BLOCK NG. BLOCK A 1TECHNIQUE IF ABLE. OR IDENTIFY HIM AS #1	VS. EVEN – BLOCK THE MOST DANGEROUS SHIRT BACKSIDE.
QB:	PIVOT ON PLAYSIDE FOOT AND CLEAR MID-LINE. PUSH BALL BACK TO BSH ON 2 ND STEP. THEN FAKE KEEP OUT PLAYSIDE.	RUN OUTSIDE THE WIDEST DEFENDER. SELL FAKE FOR 20 YARDS.
FB:	STEP LATERAL FOR ONE STEP AND LEAD BALL CARRIER THROUGH OFF-TACKLE HOLE.	LOOK INSIDE FOR AN UGLY SHIRT AS YOU RUN THROUGH THEC-GAP.
HB:	FSH: J-BLOCK THE DEFENSIVE END ON THE INSIDE NUMBER AND KEEP HIM WHERE HE'S AT OR PUSH HIM OUTSIDE.	BSH: CROSS-OVER, POCKET AND ON YOUR NEXT STEP PUSH UP FIELD. BE AT THE LINE BY 4 TH STEP. KEEP BALL LAYERED UNTIL YOU CAN SCORE!



36 POWER VS 5-2 DEFENSE

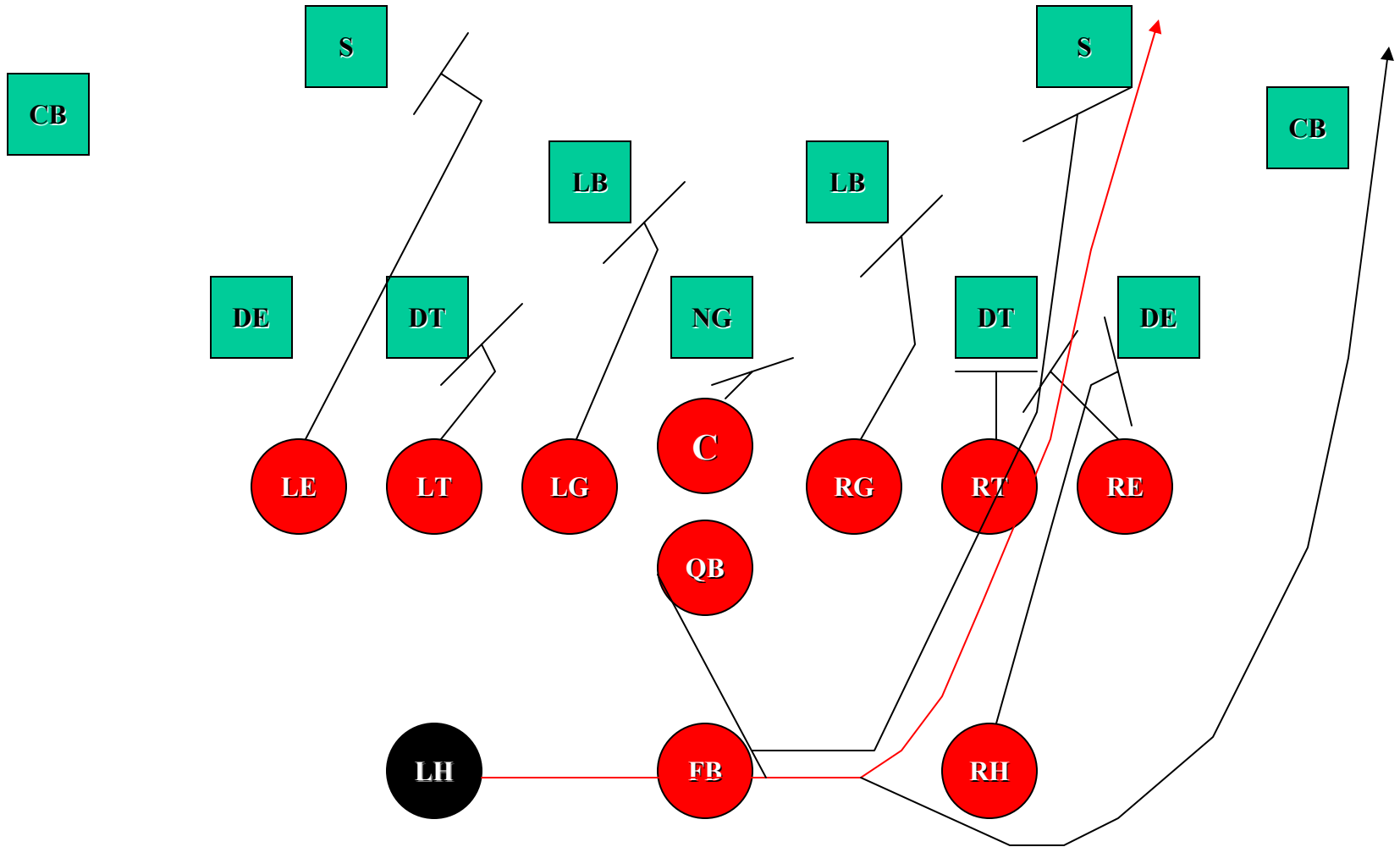

36 POWER VS. 5-3 DEFENSE

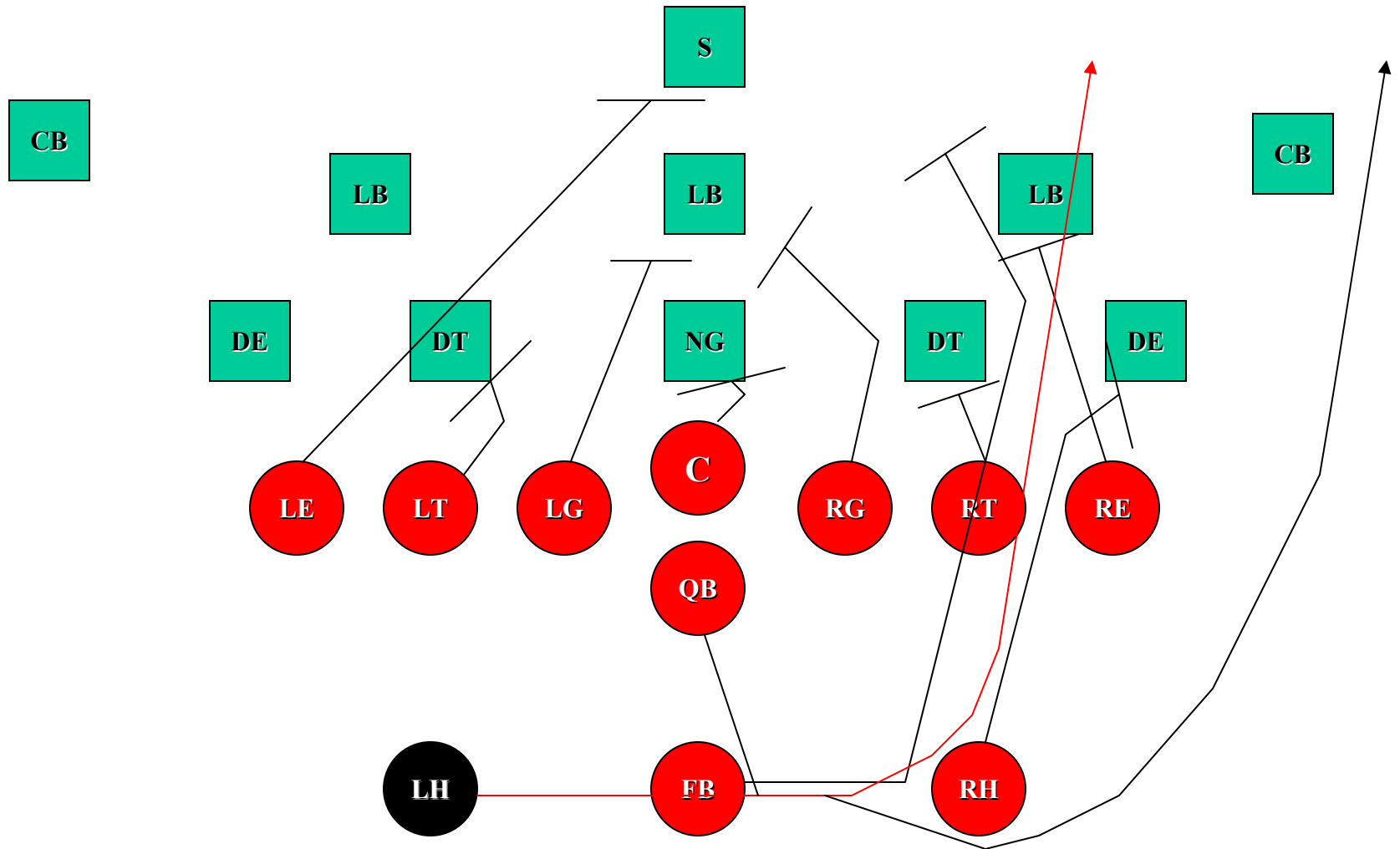

36 POWER VS. 7-1 DEFENSE

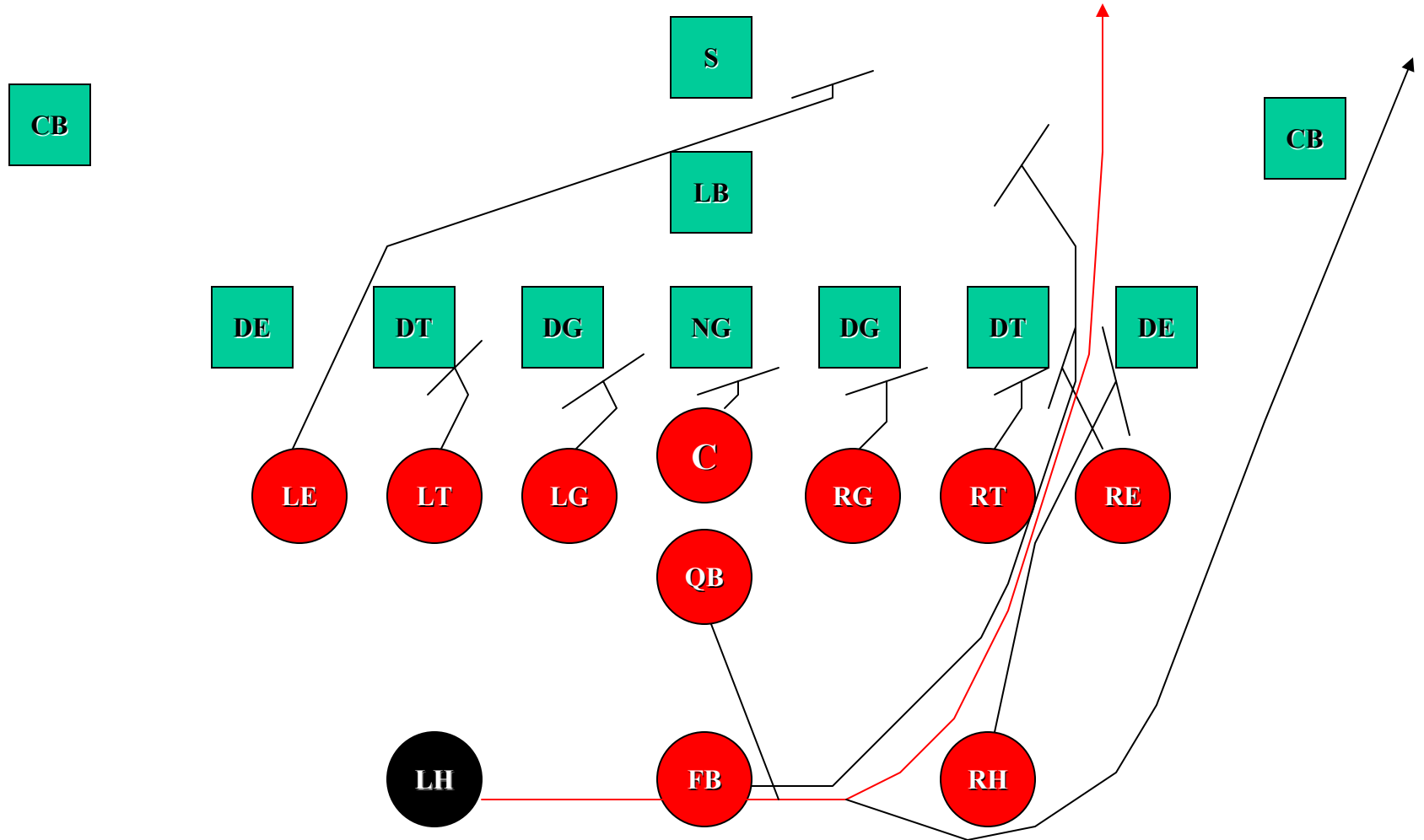

36 POWER VS. 6-1 DEFENSE

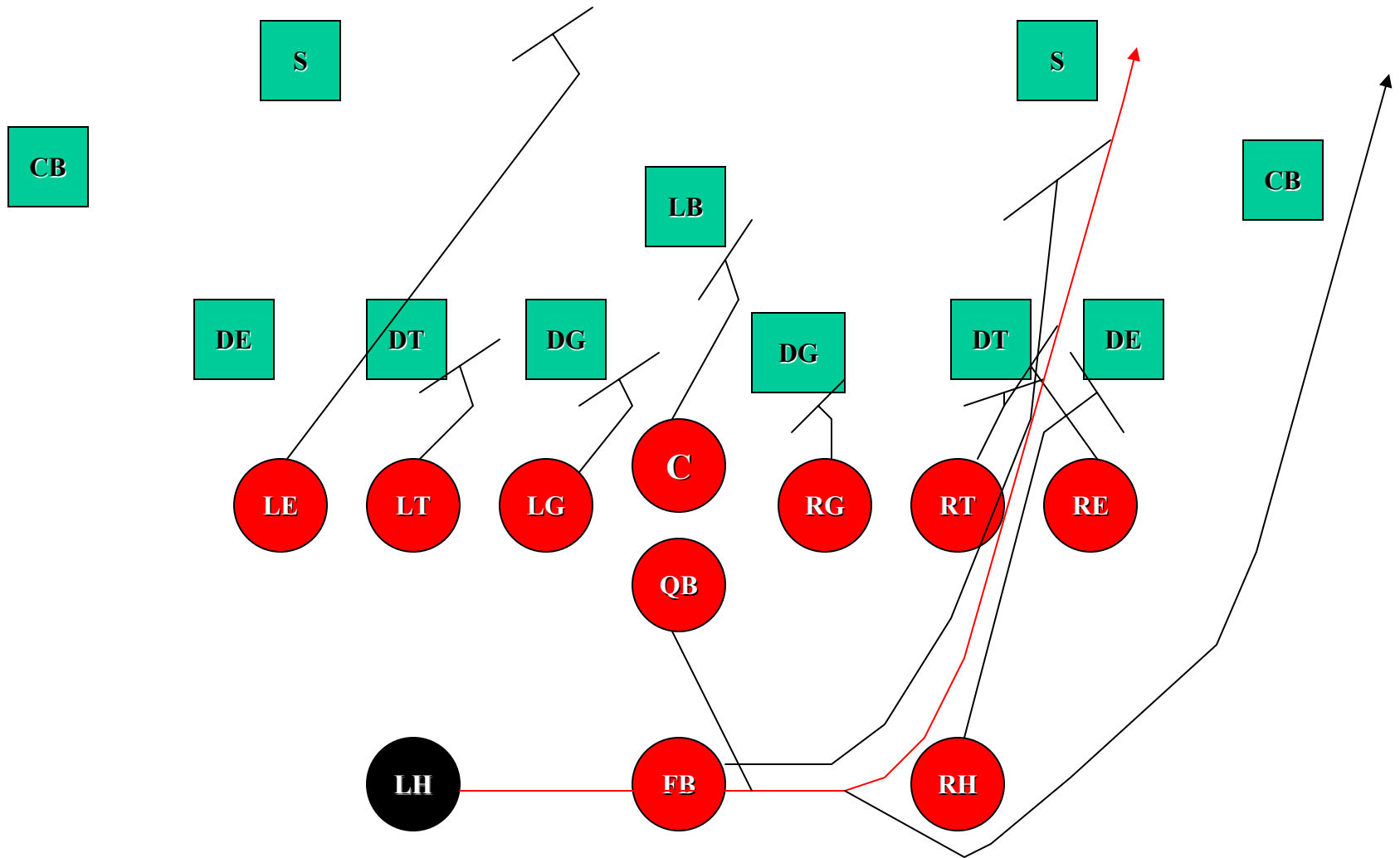

36 POWER VS. 6-5 DEFENSE

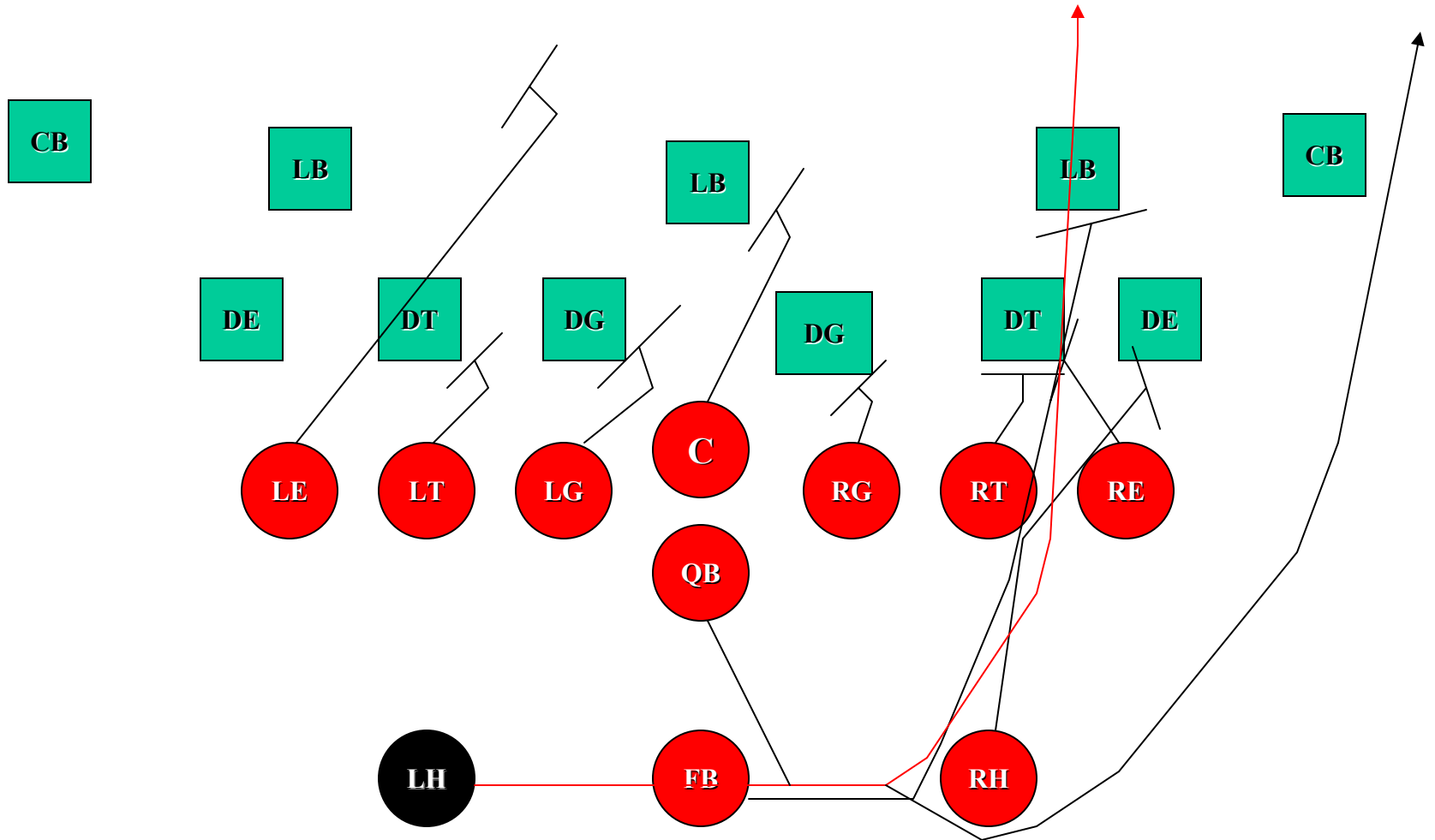

36 POWER VS. 4-3 DEFENSE

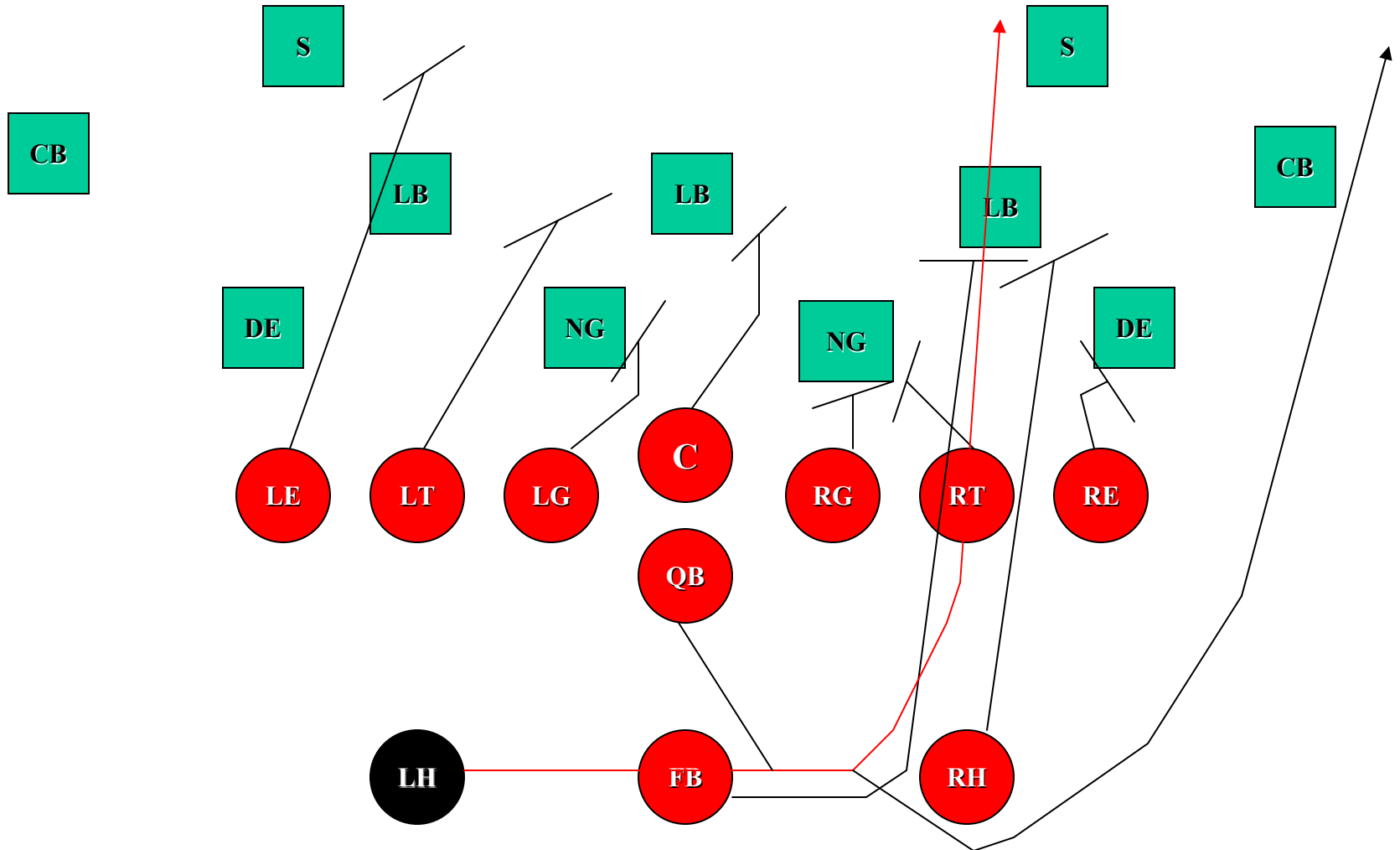

36 POWER VS. 4-4 DEFENSE

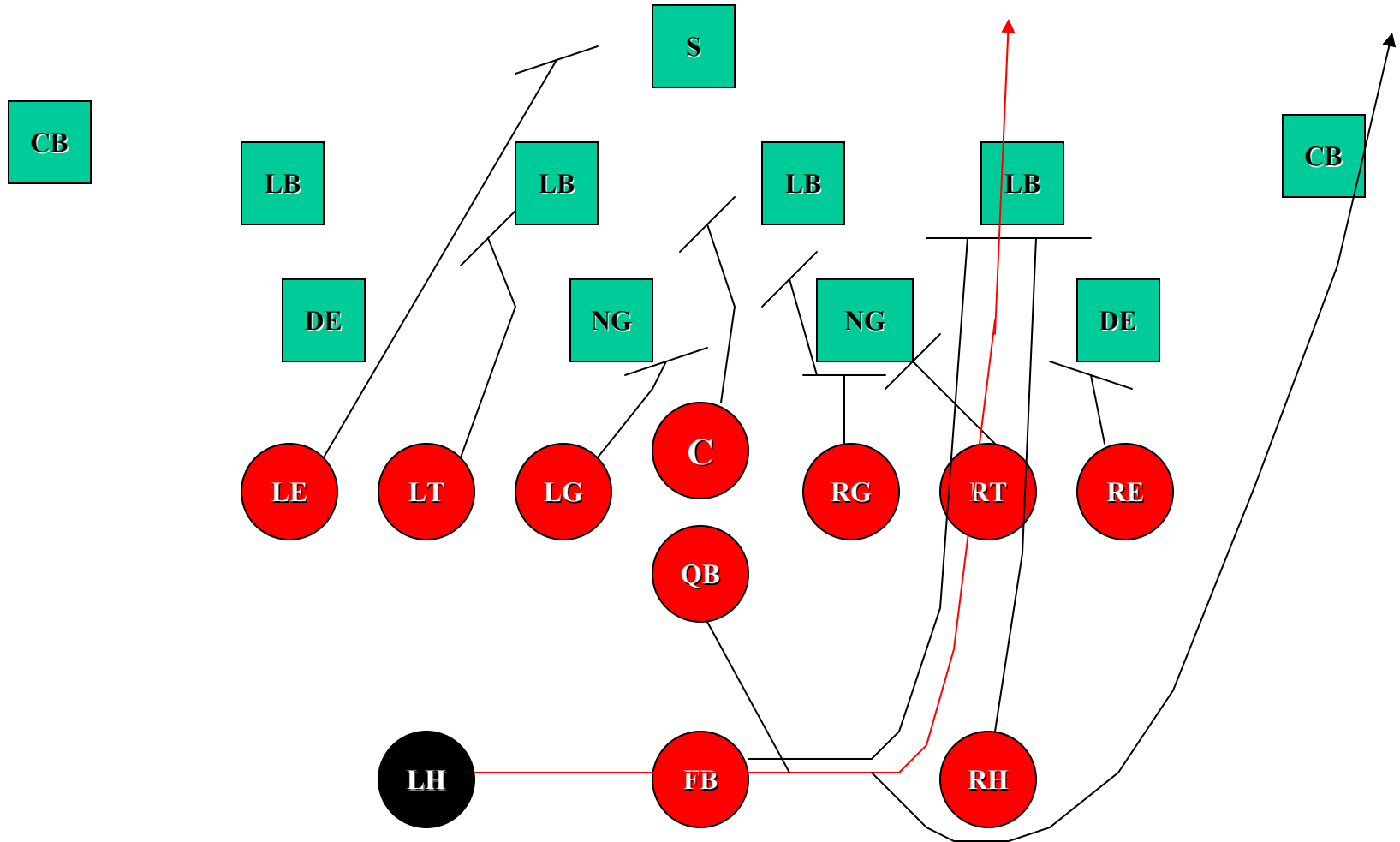

36 – 27 DOWN RULES

TE:

FSE: BLOCK DOWN ON THE 1ST MAN INSIDE. DO NOT ALLOW PENETRATION.

BSE: BLOCK THE DEFENDER IN THE MIDDLE THIRD OR HALF OF THE FIELD.

T:

FST: BLOCK DOWN ON THE 1ST MAN INSIDE. DO NOT ALLOW PENETRATION.

BST: ARC TO THE NEAR HIP OF THE MAN THE CENTER BLOCKS AND SEAL THE A-B GAP.

G:

FSG: PULL WITH A LEAD STEP AND TRAP THE FIRST UGLY SHIRT PAST THE FSE'S DOWN BLOCK.

BSG: PULL WITH A LEAD STEP AND ON YOUR 3RD STEP PUSH UP INTO THE OFF-TACKLE HOLE AND BLOCK 1ST UGLY SHIRT.

C:

VS. ODD – BLOCK NG. MUST BLOCK A 1TECHNIQUE TO THE PLAYSIDE.

VS. EVEN – BLOCK THE MOST DANGEROUS SHIRT BACKSIDE.

QB:

PIVOT ON PLAYSIDE FOOT AND CLEAR MID-LINE. PUSH BALL BACK TO BSH ON 2ND STEP. THEN FAKE KEEP OUT PLAYSIDE.

RUN OUTSIDE THE WIDEST DEFENDER. SELL FAKE FOR 20 YARDS.

FB:

STEP FORWARD WITH PS FOOT AND MAKE A PROXIMITY FAKE W/QB. POCKET AND ROCK THE CRADLE.

RUN INTO THE FRONT SIDE B-GAP LOOKING FOR AN UGLY SHIRT TO BLOCK.

HB:

FSH: LINE UP IN A WING AND BLOCK THE DEFENDER IN THE MIDDLE THIRD OR HALF.

BSH: CROSS-OVER, POCKET AND ON YOUR NEXT STEP PUSH UP FIELD. BE AT THE LINE BY 4TH STEP. KEEP BALL LAYERED UNTIL YOU CAN SCORE!

236 DOWN VS. 6-2 DEFENSE

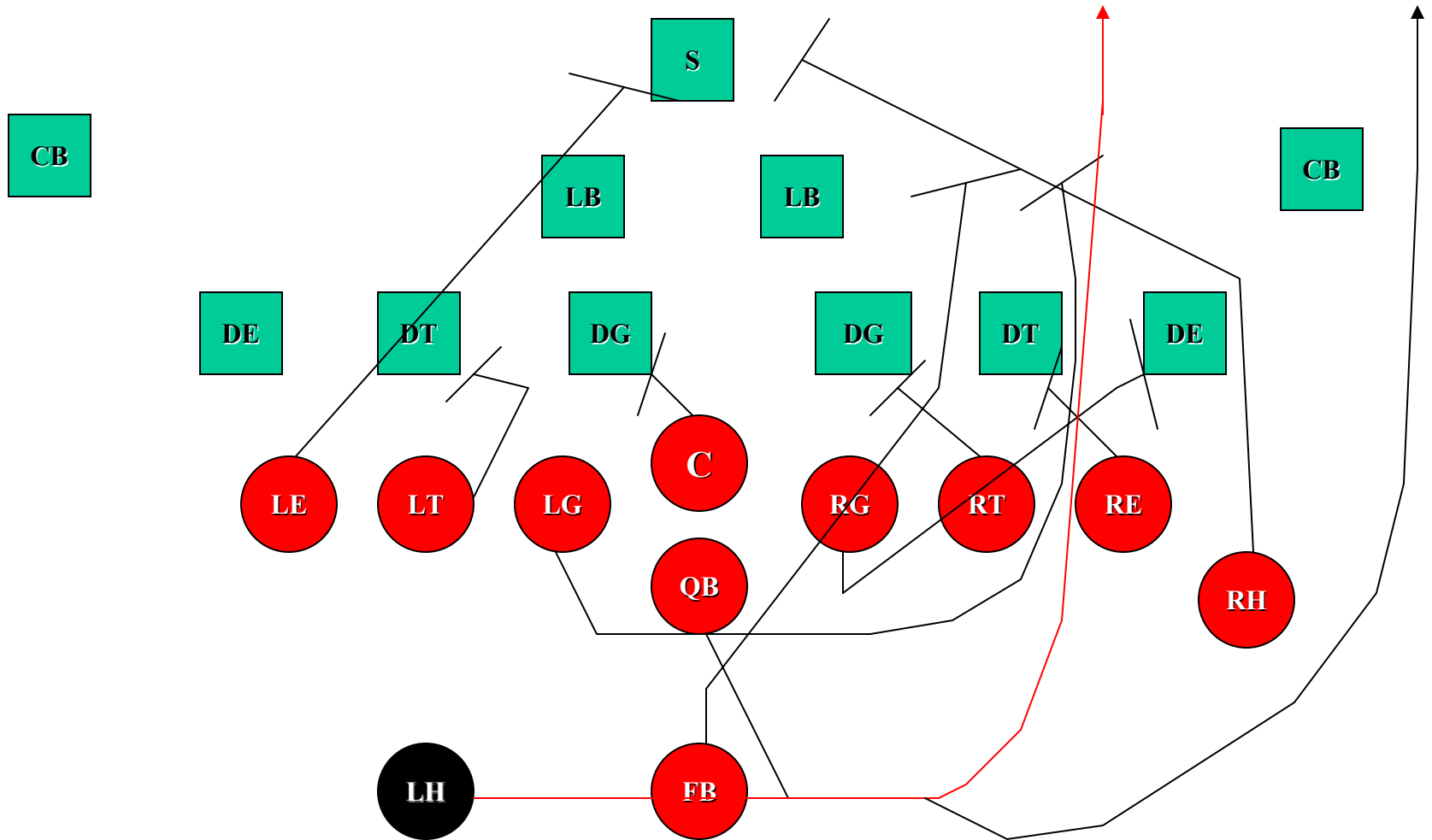

36 – 27 KEEP OUT RULES

TE:

FSE: BLOCK DOWN ON THE 1ST MAN INSIDE THE DEFENSIVE END. APPLY STACK RULES.

BSE: TAILGATE. YOU AND THE BST ARE RESPONSIBLE FOR THE OUTSIDE TWO ON THE LINE.

T:

FST: BLOCK THE 2ND MAN OUTSIDE THE CENTER. APPLY STACK RULES.

BST: TAILGATE. YOU AND THE BSE ARE RESPONSIBLE FOR THE OUTSIDE TWO ON THE LINE.

G:

FSG: BLOCK THE 1ST MAN OUTSIDE CENTER. APPLY STACK RULES.

BSG: LEAD STEP AND PULL NORMAL. BUBBLE ON 3RD STEP AND SWING AROUND FSE'S BLOCK. BLOCK THE FORCE.

C:

VS. ODD – BLOCK NG. BLOCK A 1 TECHNIQUE IF ABLE. OR IDENTIFY HIM AS #1

VS. EVEN – BLOCK THE MOST DANGEROUS SHIRT BACKSIDE.

QB:

PIVOT ON PLAYSIDE FOOT AND CLEAR MID-LINE. PUT THE BALL IN THE BSH POCKET ON 2ND STEP AND RIDE HIM INTO THE LINE. MAKE A GREAT RIDE WITH HB!

PULL THE BALL AND PUT IT ON HIP. FOLLOW THE PULLING GUARD AND READ HIS BLOCK. KEEP THE BALL ON HIP AS LONG AS POSSIBLE.

FB:

STEP FORWARD WITH PS FOOT AND THEN VEER INTO THE BACKSIDE A-B GAP AND BLOCK.

MUST GET HEELS TO THE L.O.S. YOU ARE RESPONSIBLE FOR THE 3RD MAN IN FROM OUTSIDE.

HB:

FSH: BLOCK THE D-END AS ON 36-27. ON THE LAST STEP BEFORE CONTACT GET YOUR HEAD ON HIS OUTSIDE # AND HOOK HIM IN. GET BETWEEN HIM AND QB.

BSH: RUN YOUR OFF-TACKLE PATH SLOWER AND TIGHTER THAN NORMAL. STAY LAYERED AND ROCK THE CRADLE. SELL FAKE FOR 20 YARDS.



36 KEEP OUT VS. 5-2 DEFENSE

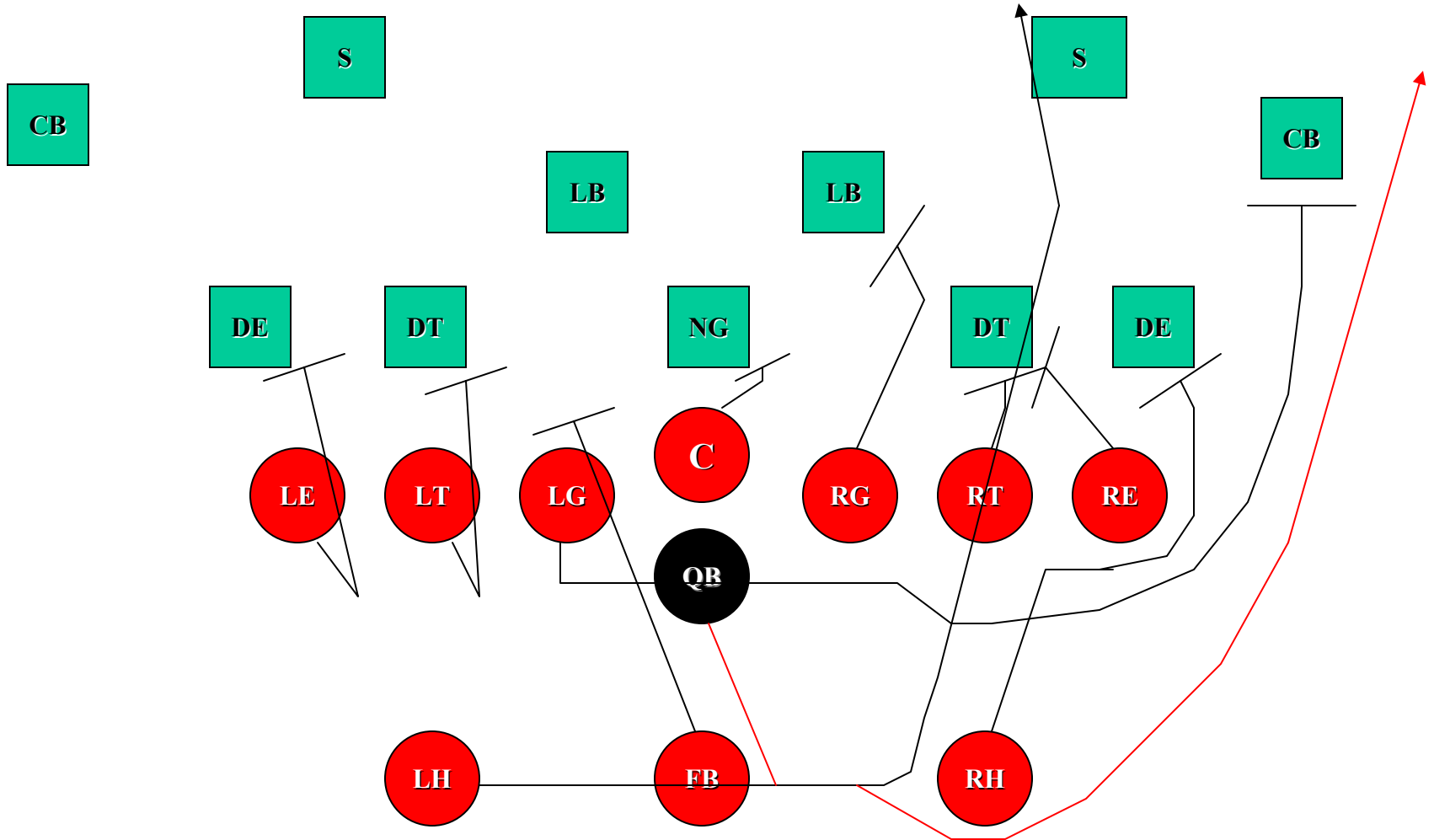

36 KEEP OUT VS. 5-3 DEFENSE

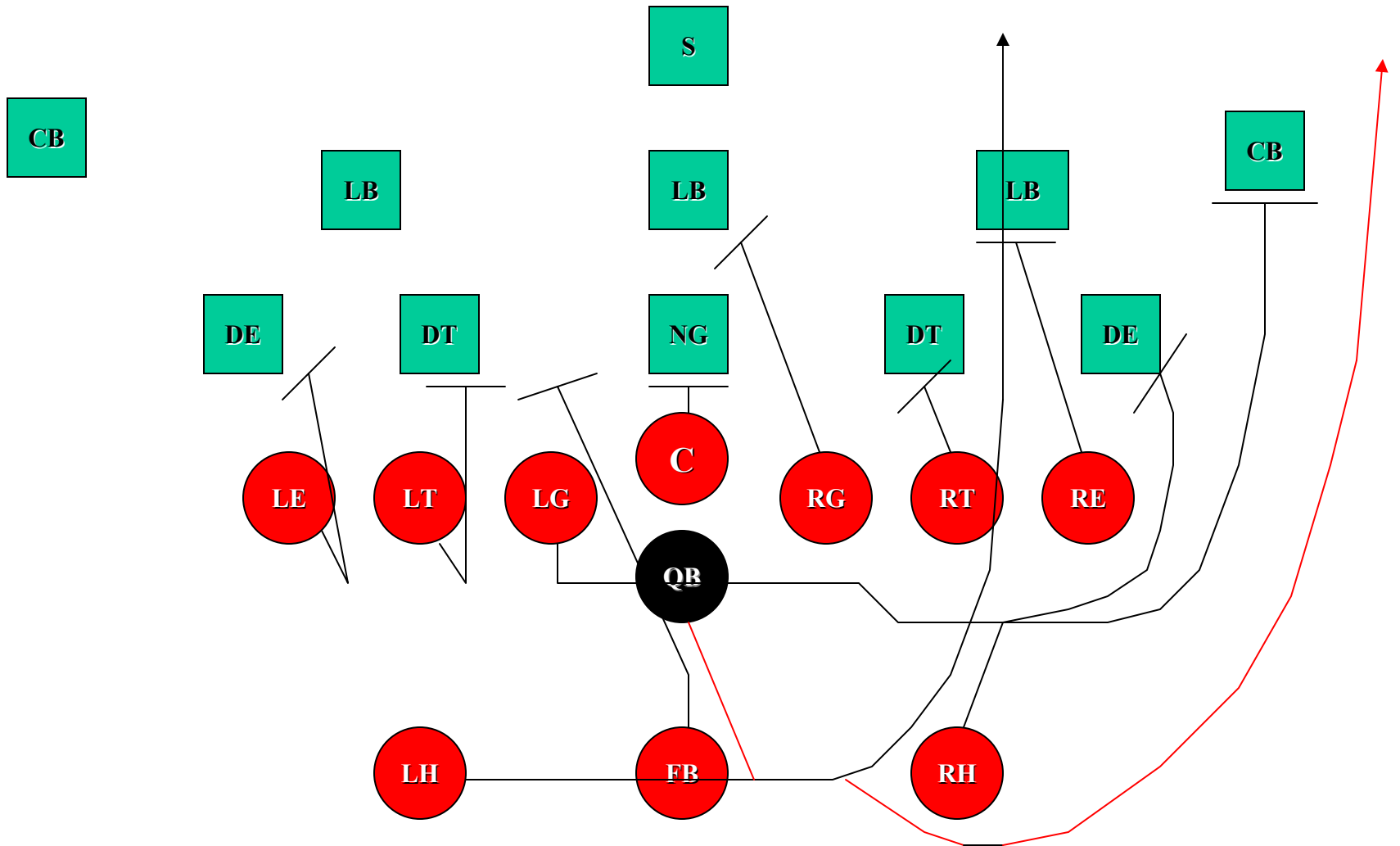

36 KEEP OUT VS. 7-1 DEFENSE

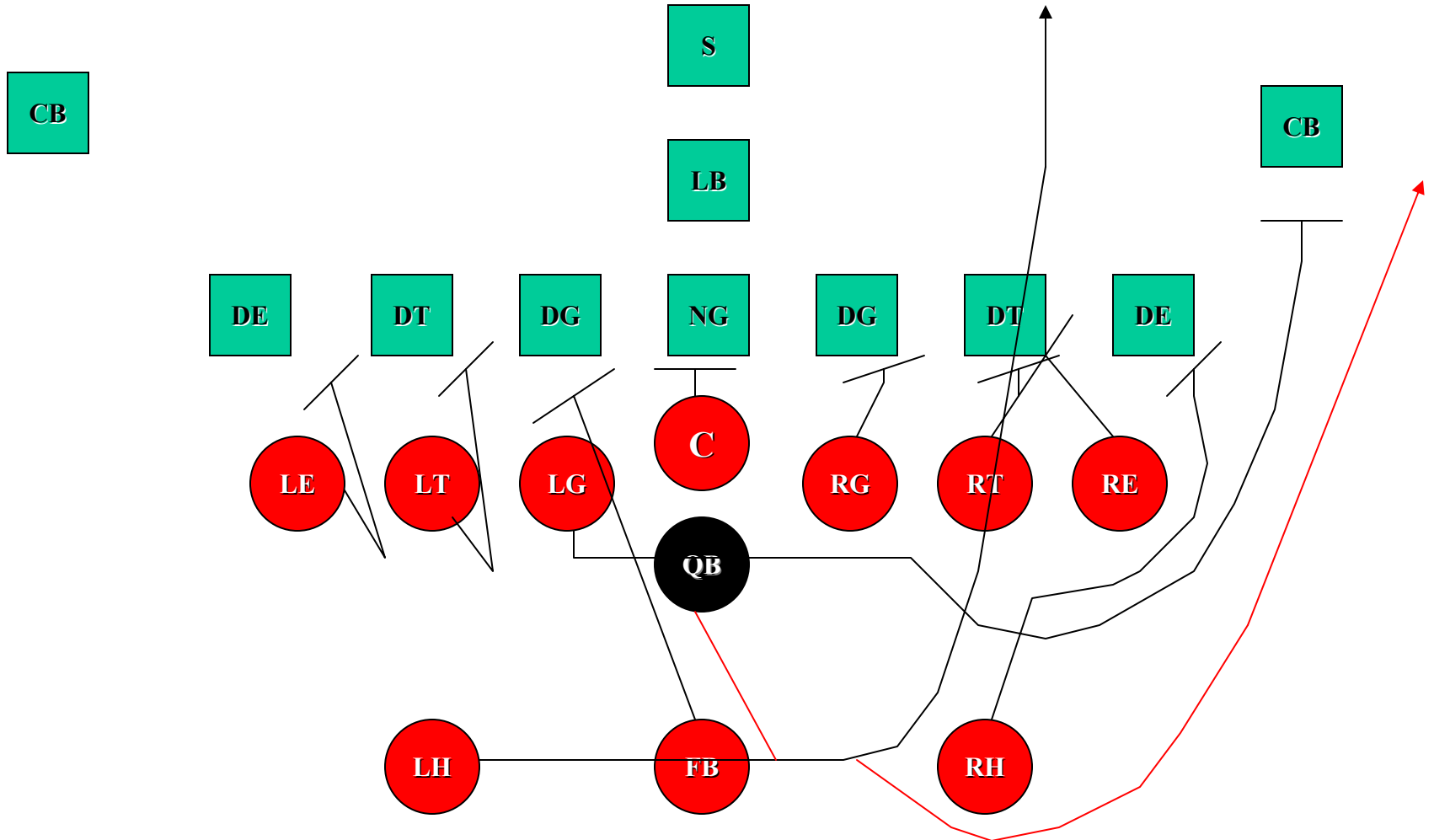

36 KEEP OUT VS. 6-1 DEFENSE

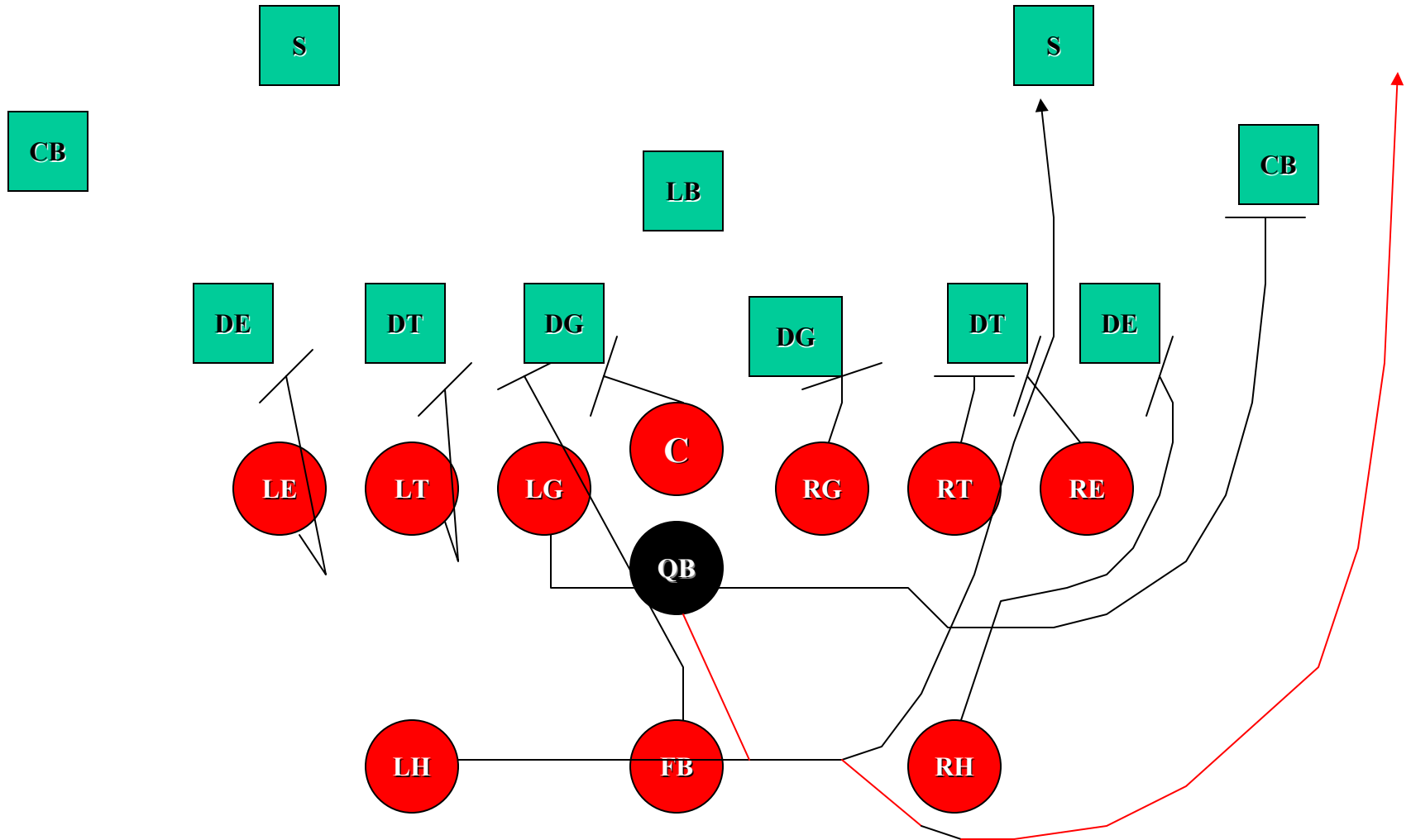

36 KEEP OUT VS. 6-2 DEFENSE

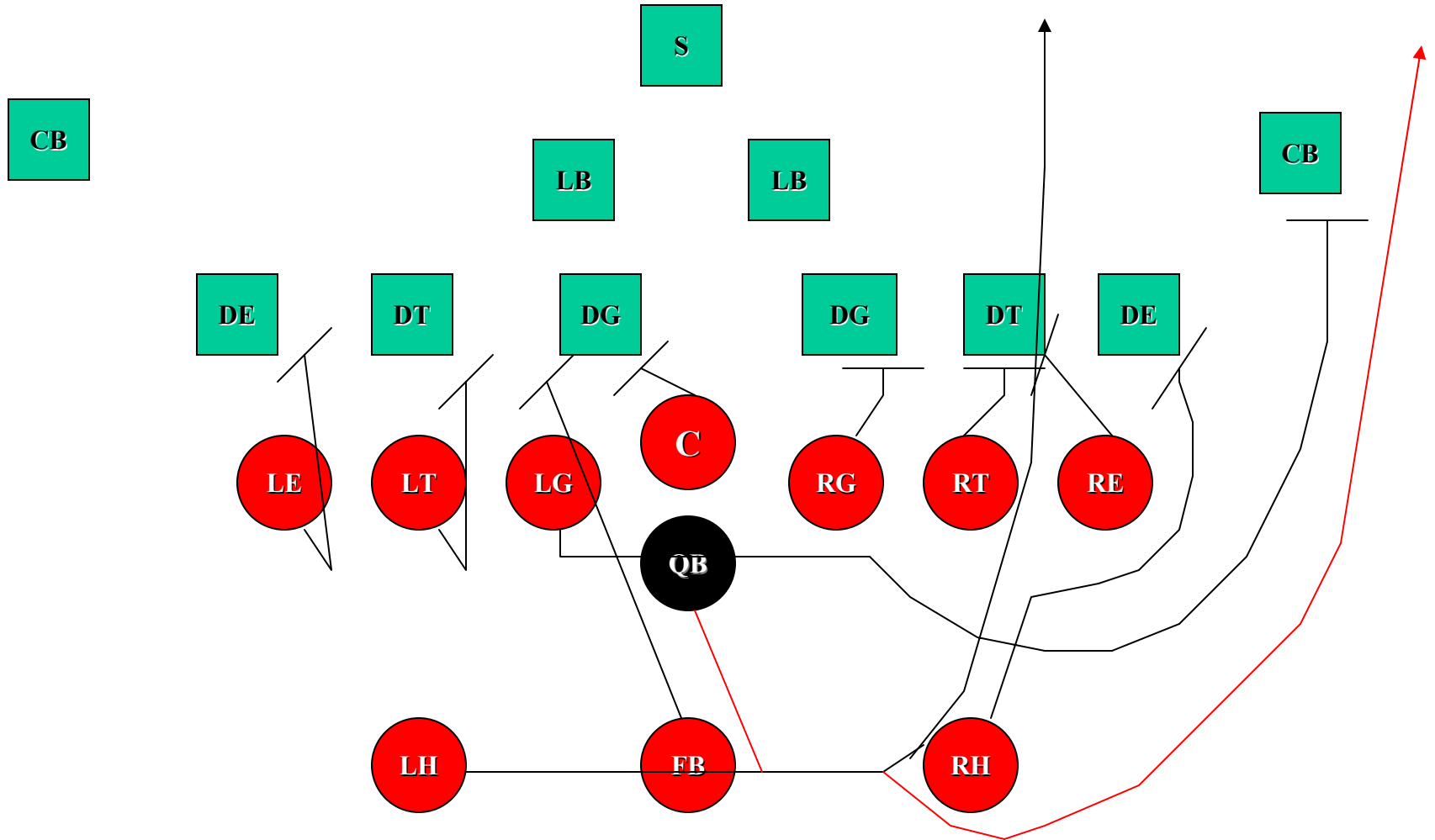

36 KEEP OUT VS. 6-5 DEFENSE

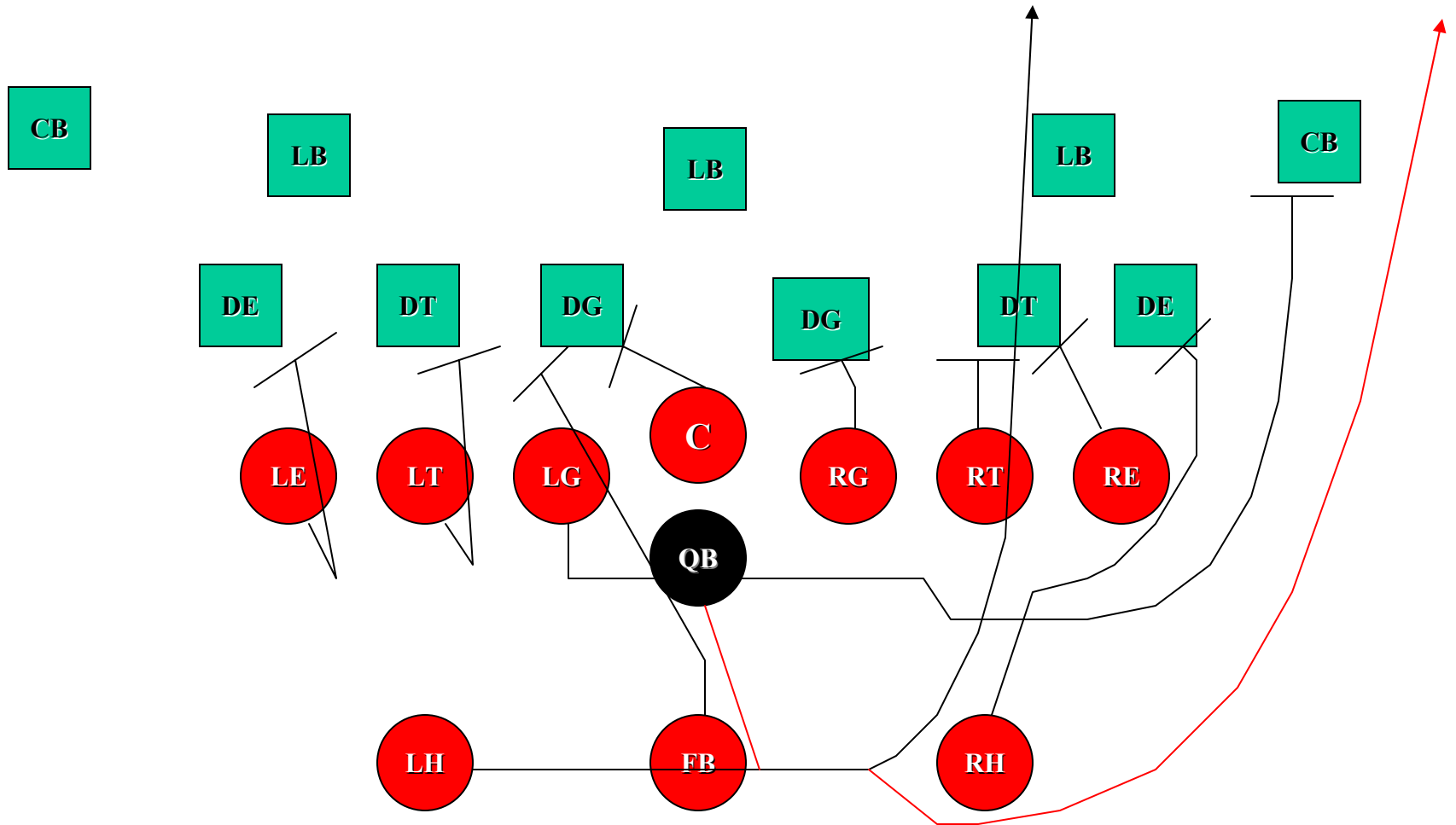

36 KEEP OUT VS. 4-3 DEFENSE

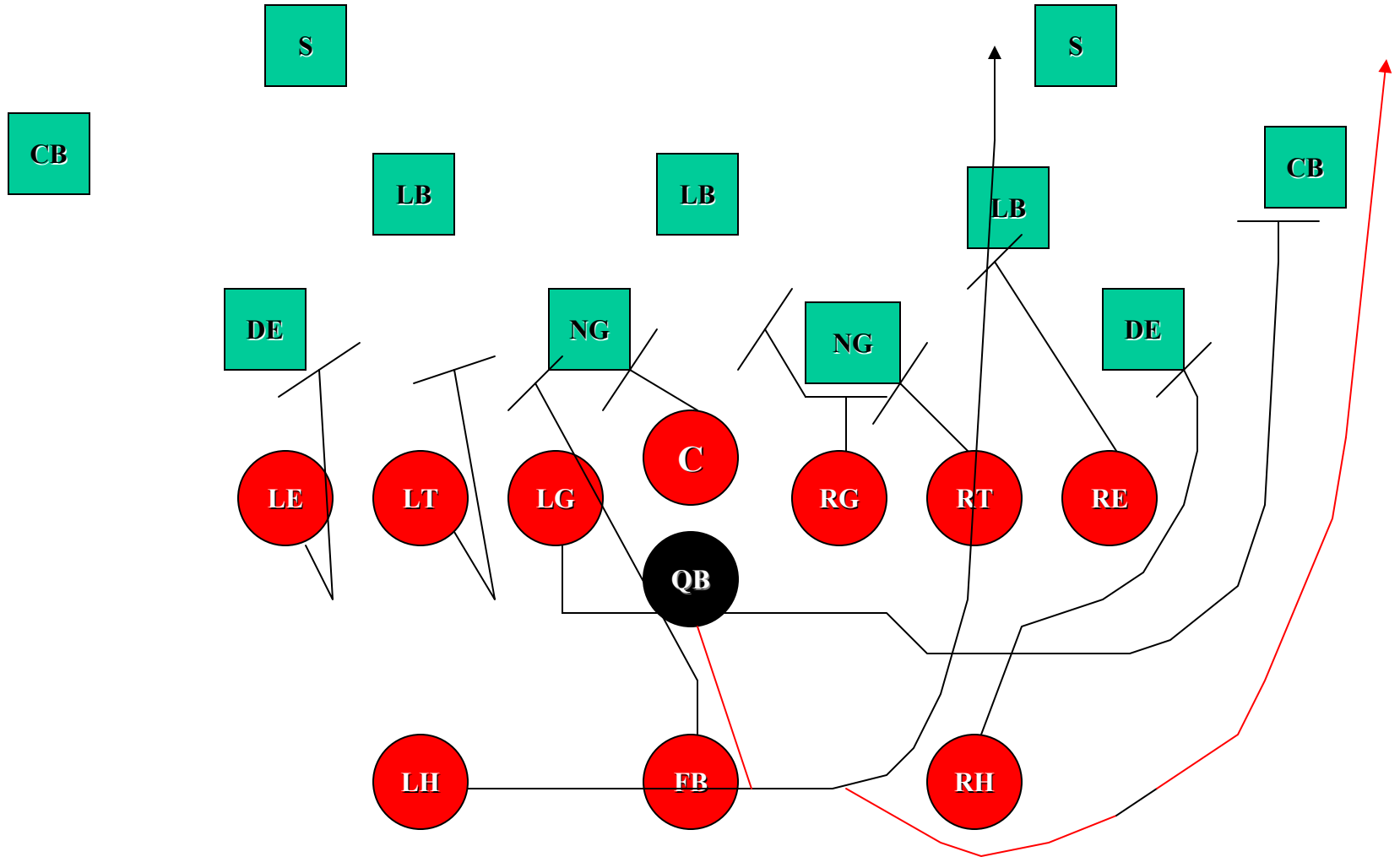

36 KEEP OUT VS. 4-4 DEFENSE

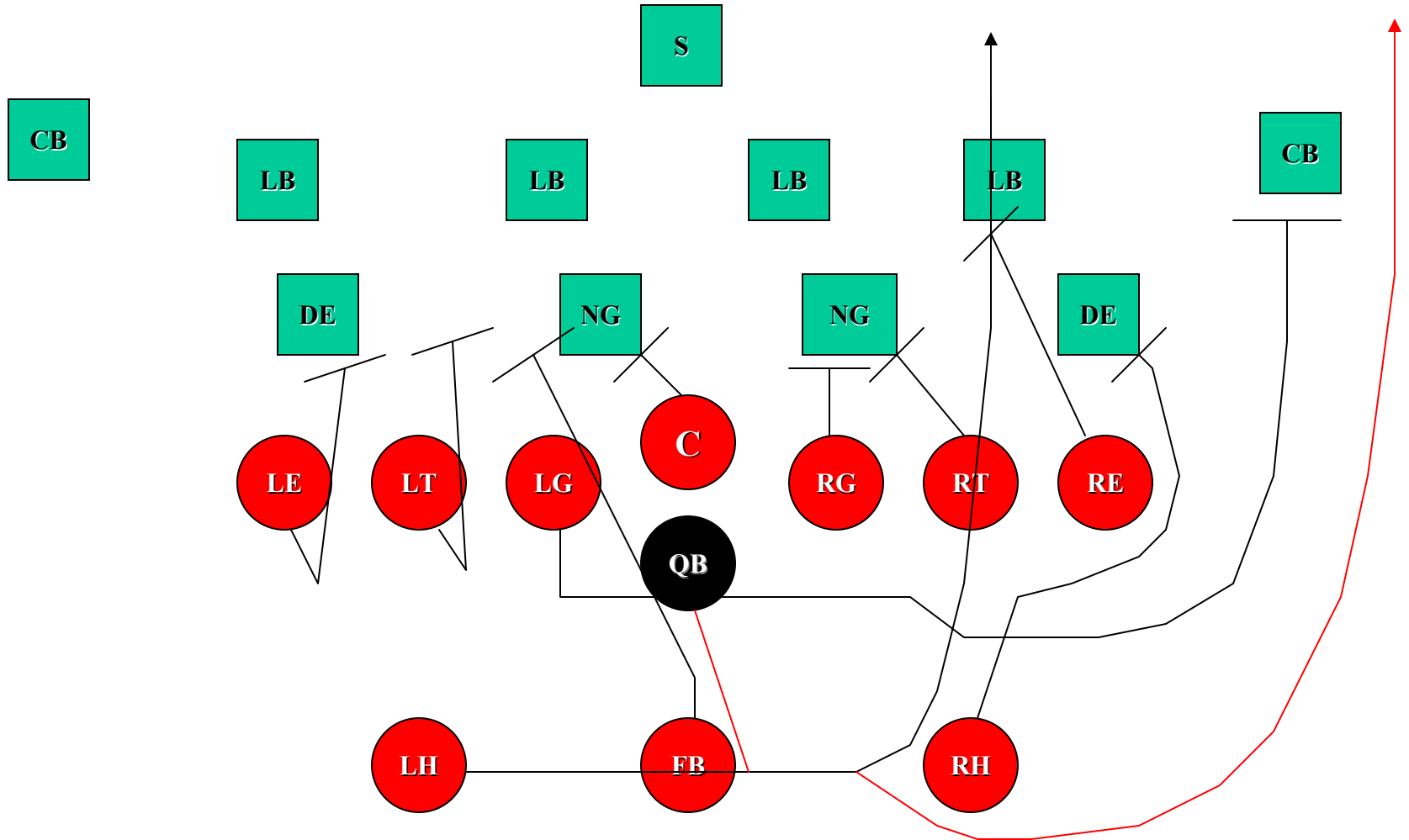

36 – 27 REVERSE RULES

TE:

FSE: BLOCK DOWN ON THE 1ST MAN INSIDE THE DEFENSIVE END. APPLY STACK RULES.

BSE: BUCKET STEP AND PULL, FOLLOWING THE BSG. READ HIS BLOCK, TURN UP FIELD AND BLOCK FIRST WRONG COLOR.

T:

FST: BLOCK THE SECOND MAN OUTSIDE THE CENTER. APPLY STACK RULES.

BST: BLOCK SOLID ON #2. VS. 1-2 STACK CO-OP W/CENTER.

G:

FSG: BLOCK THE 1ST MAN OUTSIDE CENTER. APPLY STACK RULES.

BSG: PULL AND TRAP 1ST UGLY SHIRT PAST THE FSE's DOWN BLOCK.

C:

VS. ODD – BLOCK NG. BLOCK A 1TECHNIQUE IF ABLE. OR IDENTIFY HIM AS #1

VS. EVEN – BLOCK THE MOST DANGEROUS SHIRT BACKSIDE.

QB:

PIVOT ON BACKSIDE FOOT AND CLEAR MIDLINE. GET DEPTH AND GIVE BALL TO BALL CARRIER. THEN FAKE COUNTER BOOT AWAY.

RUN OUTSIDE THE WIDEST DEFENDER. SELL FAKE FOR 20 YARDS.

FB:

STEP FORWARD WITH PS FOOT AND MAKE A PROXIMITY FAKE W/QB. POCKET AND ROCK THE CRADLE.

RUN INTO THE BACK SIDE B-GAP LOOKING FOR AN UGLY SHIRT TO BLOCK.

HB:

FSH: FAKE THE OFF-TACKLE PLAY BACKSIDE. POCKET AND ROCK THE CRADLE . BE PREPARED TO PEEL A DEFENDER OFF THE PULLING END.

BSH: DROP STEP AND MAKE THE EXCHANGE WITH QB. READ THE GUARD'S BLOCK AND FOLLOW THE PULLING END INTO THE HOLE.



27 REVERSE VS. 5-3 DEFENSE

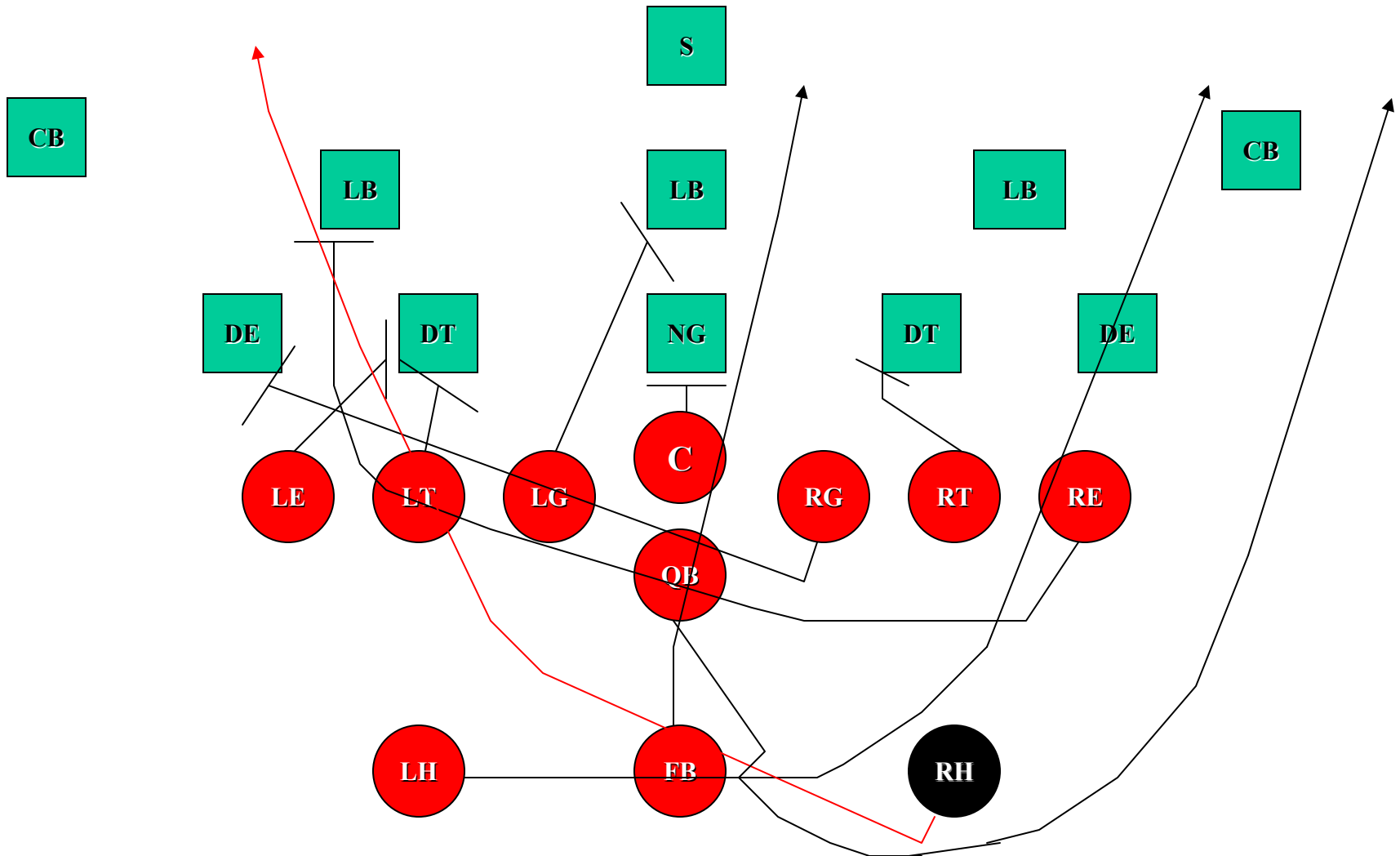

27 REVERSE VS. 7-1 DEFENSE

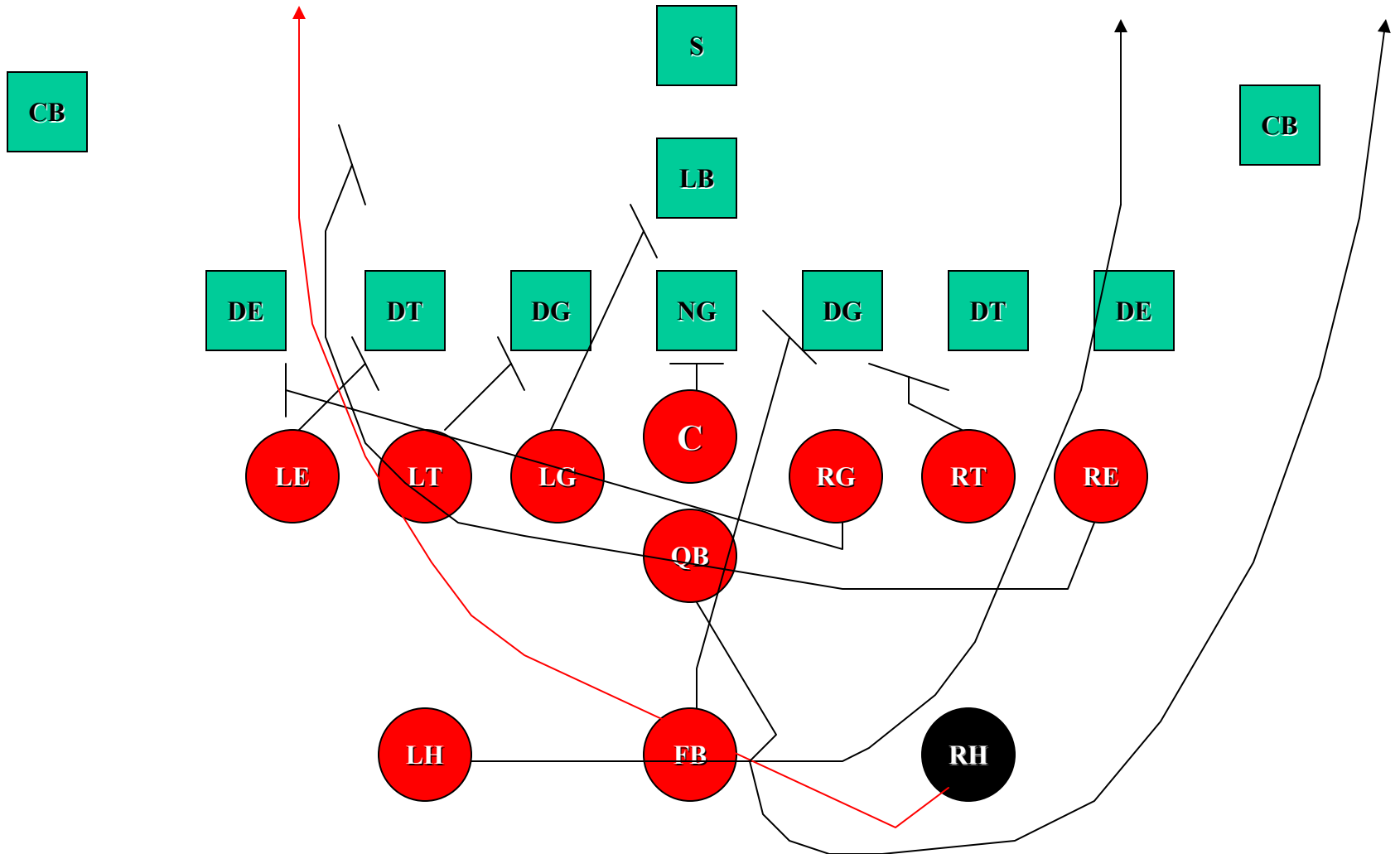

27 REVERSE VS. 6-1 DEFENSE

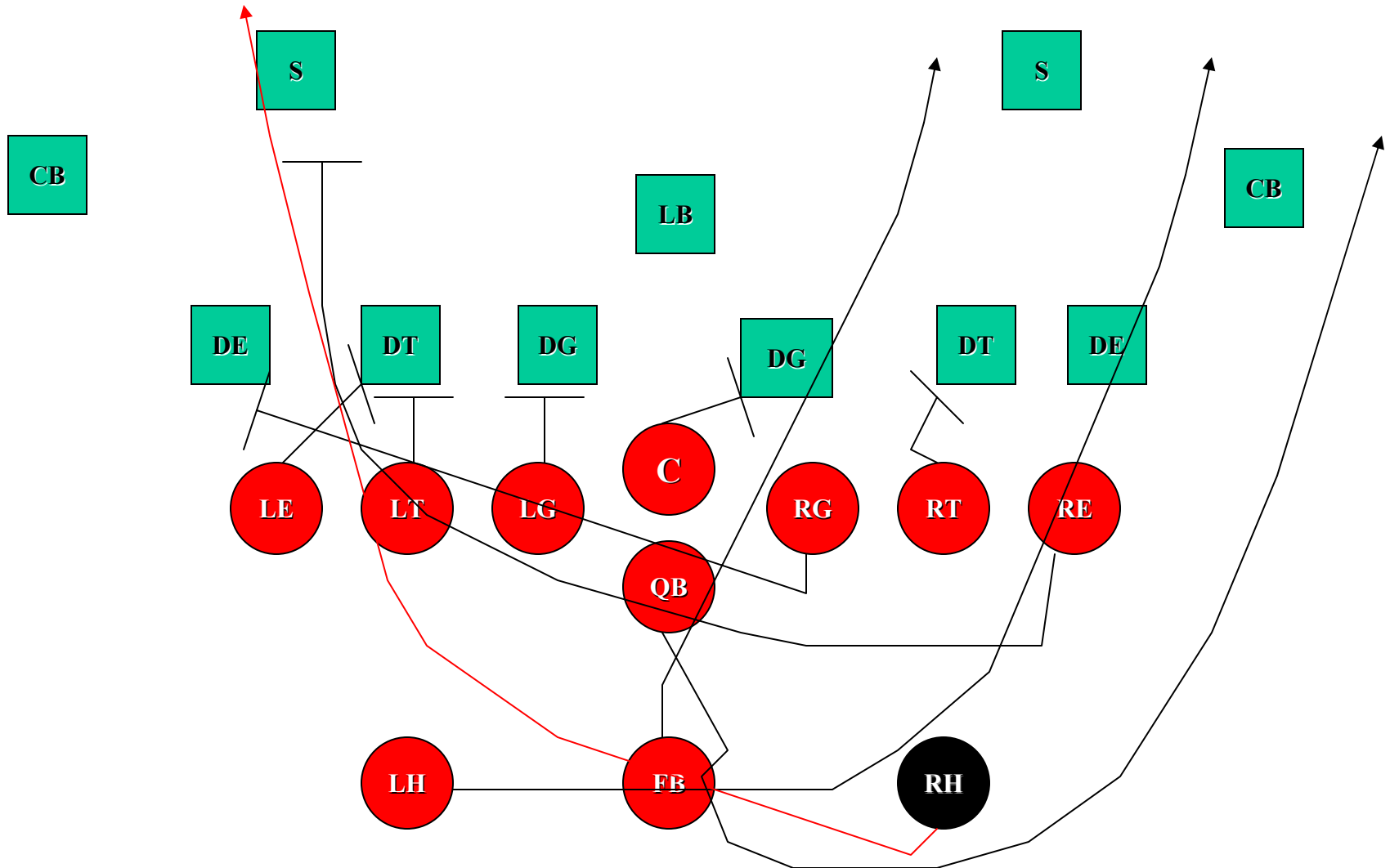

27 REVERSE VS. 6-2 DEFENSE

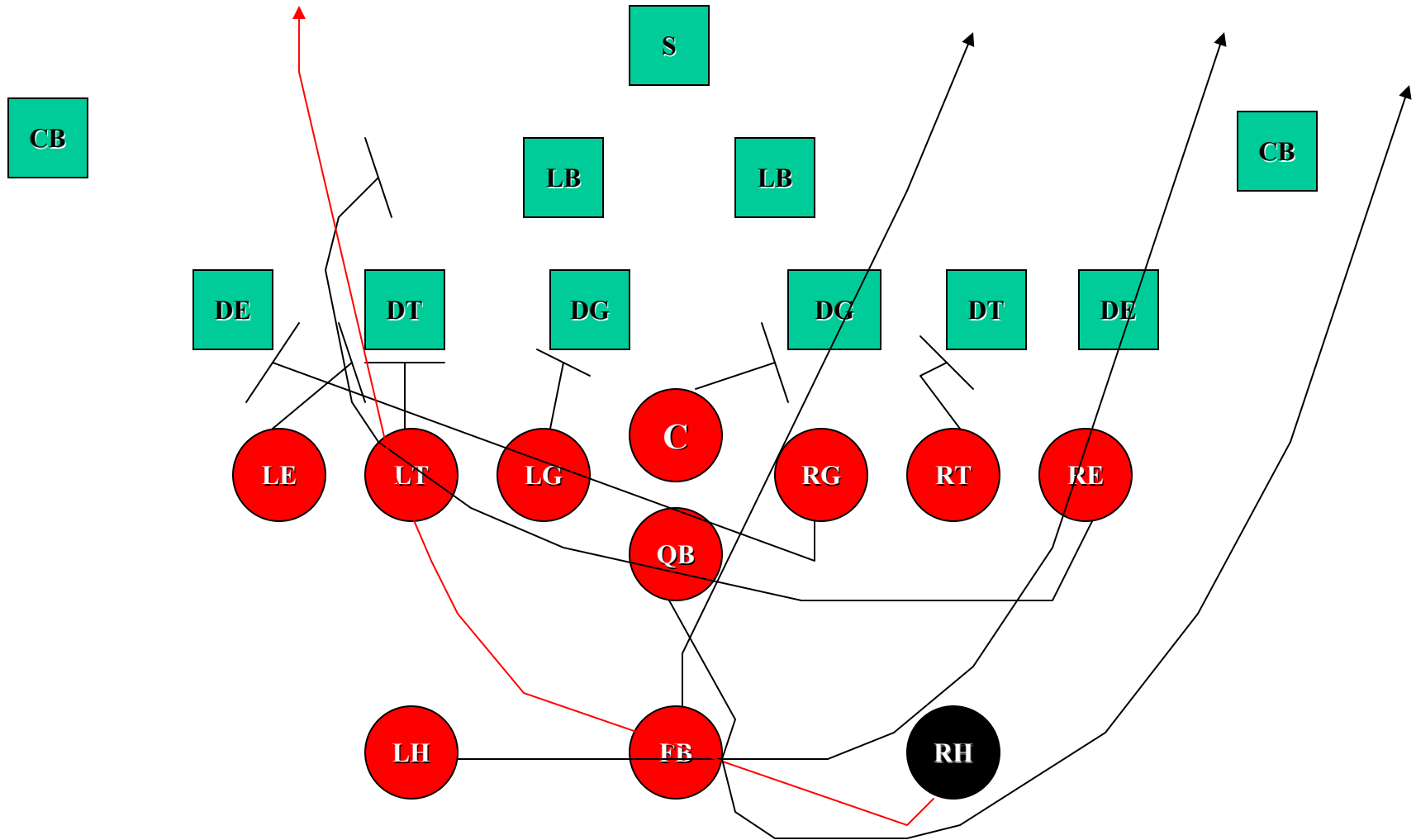

27 REVERSE VS. 6-5 DEFENSE

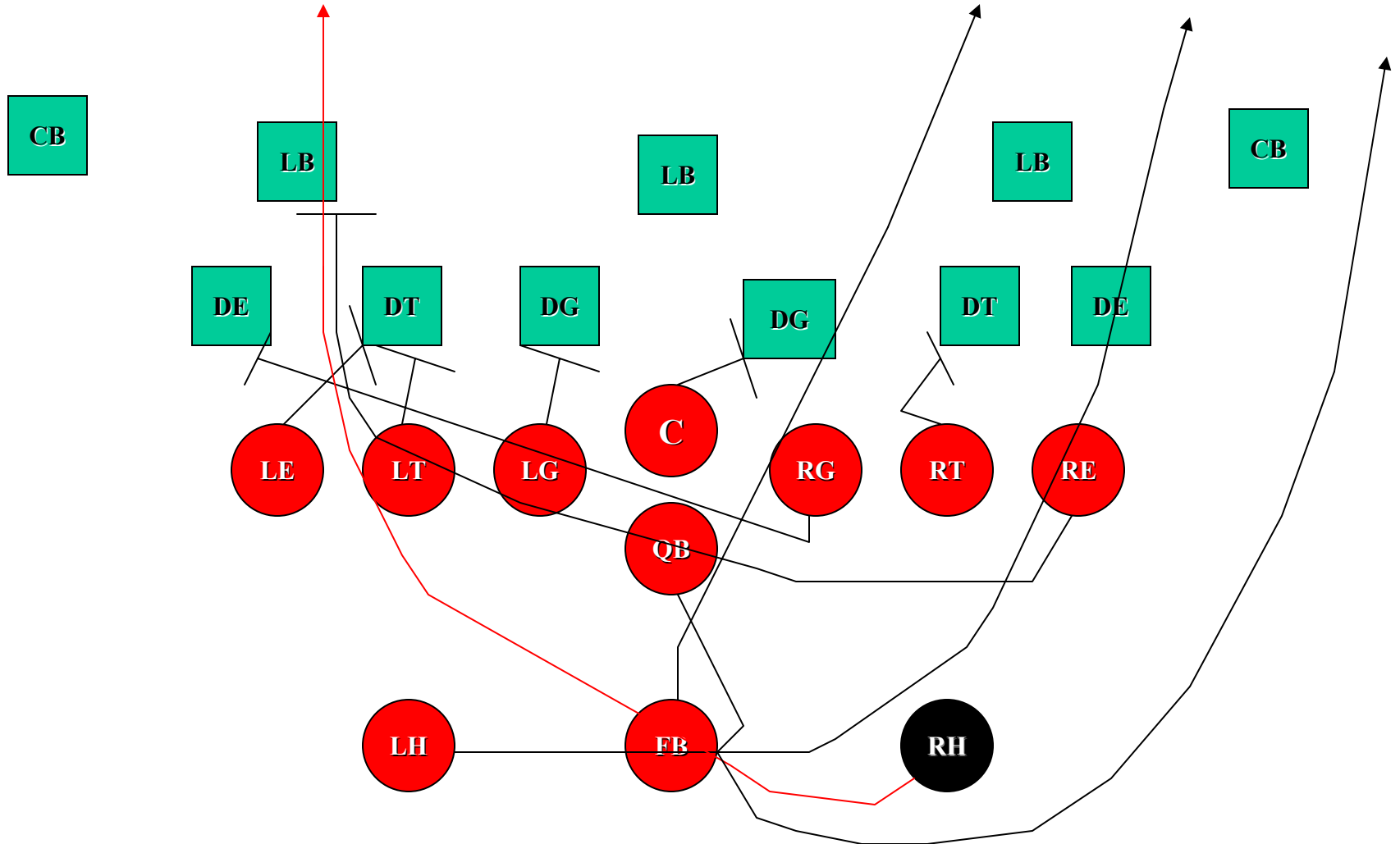

27 REVERSE VS. 4-3 DEFENSE

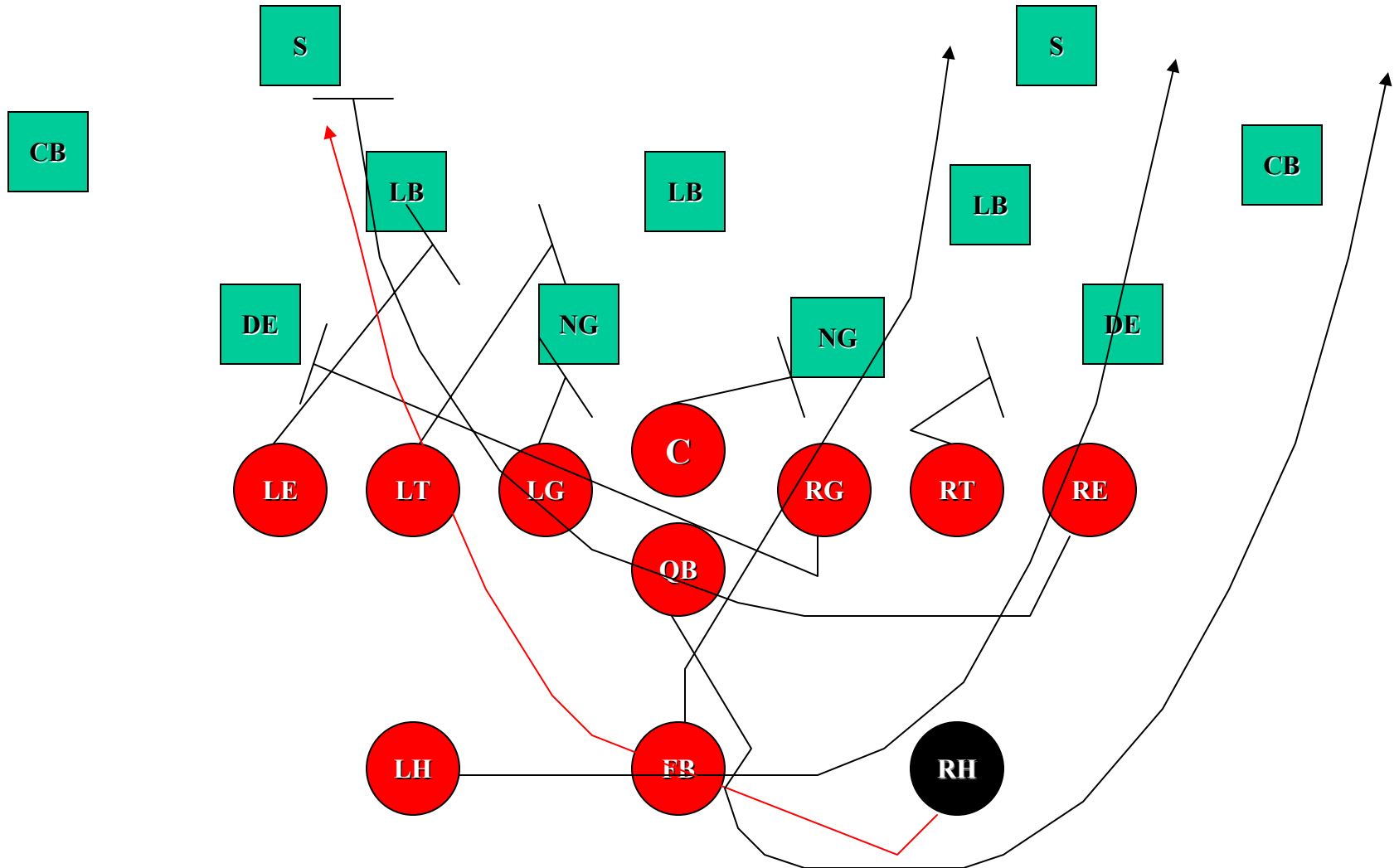

27 REVERSE VS. 4-4 DEFENSE

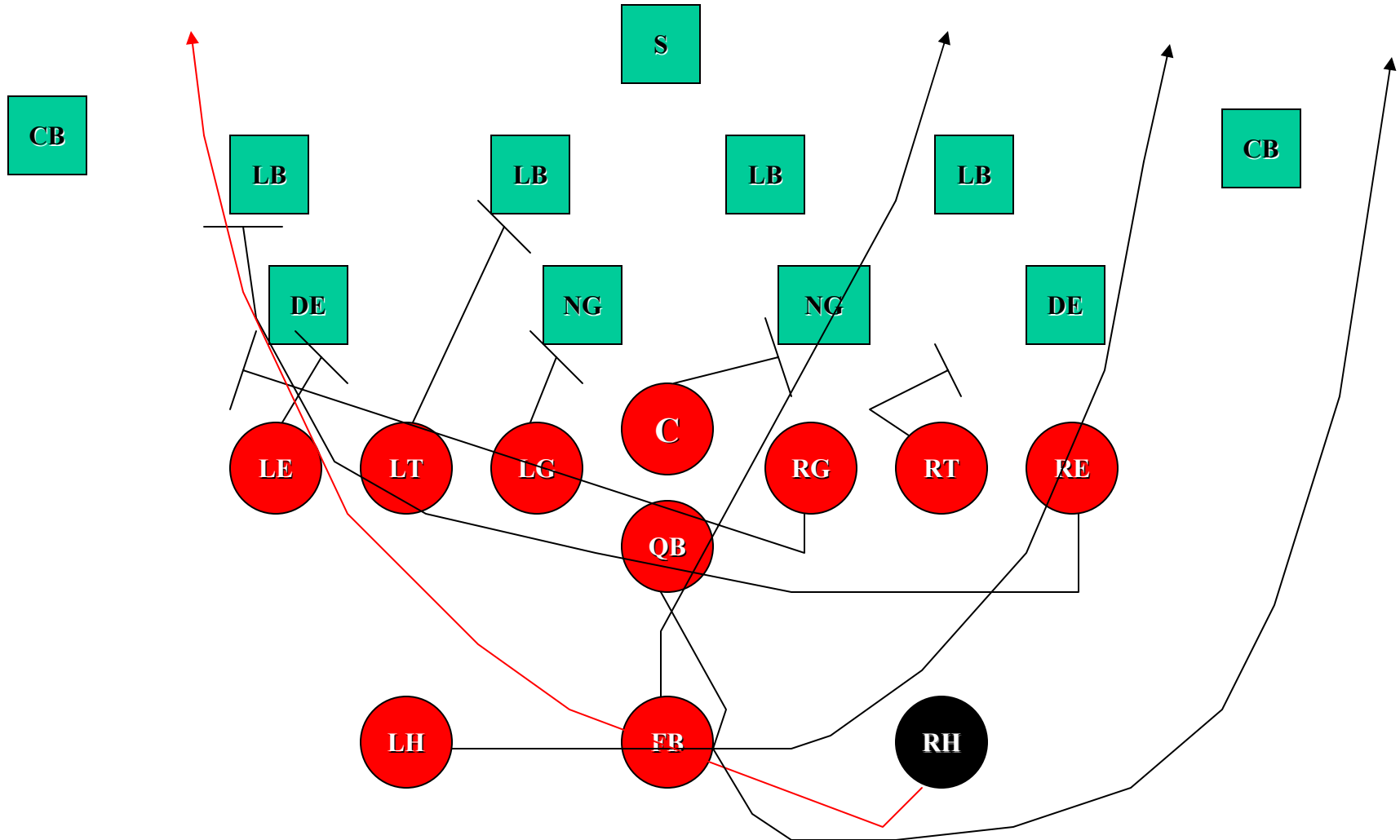

36 – 27 REVERSE SOLID

TE:

FSE: BLOCK DOWN ON THE 1ST MAN INSIDE THE DEFENSIVE END. APPLY STACK RULES.

BSE: BUCKET STEP AND PULL PLAYSIDE. READ THE FB'S BLOCK AND TURN UP FIELD. BLOCK 1ST UGLY SHIRT IN HOLE.

T:

FST: BLOCK THE 2ND MAN OUTSIDE THE CENTER. APPLY STACK RULES.

BST: BLOCK SOLID ON #2 OUTSIDE CENTER. APPLY STACK RULES.

G:

FSG: BLOCK THE 1ST MAN OUTSIDE CENTER. APPLY STACK RULES.

BSG: BLOCK SOLID ON #1 OUTSIDE CENTER. APPLY STACK RULES.

C:

VS. ODD – BLOCK NG. BLOCK A 1 TECHNIQUE IF ABLE OR IDENTIFY HIM AS #1.

VS. EVEN – BLOCK THE MOST DANGEROUS LB BACKSIDE.

QB:

PIVOT ON BACKSIDE FOOT AND CLEAR THE MID-LINE. GET DEPTH AND GIVE BALL TO BALL CARRIER. THEN FAKE COUNTER BOOT AWAY.

RUN OUTSIDE THE WIDEST DEFENDER. CARRY OUT FAKE FOR AT LEAST 20 YARDS.

FB:

STEP FORWARD WITH BACKSIDE FOOT THEN VEER TO THE BACKSIDE AND J-BLOCK THE D-END.

KEEP HIM WHERE HE'S AT OR PUSH HIM OUTSIDE.

HB:

FSH: FAKE THE OFF-TACKLE PLAY BACKSIDE. POCKET AND ROCK THE CRADLE. BE PREPARED TO PEEL A DEFENDER OFF THE PULLING END.

BSH: DROP STEP AND MAKE EXCHANGE WITH QB. READ THE FB'S BLOCK AND FOLLOW THE PULLING END INTO THE HOLE.



27 REVERSE SOLID VS. 5-2

DEFENSE

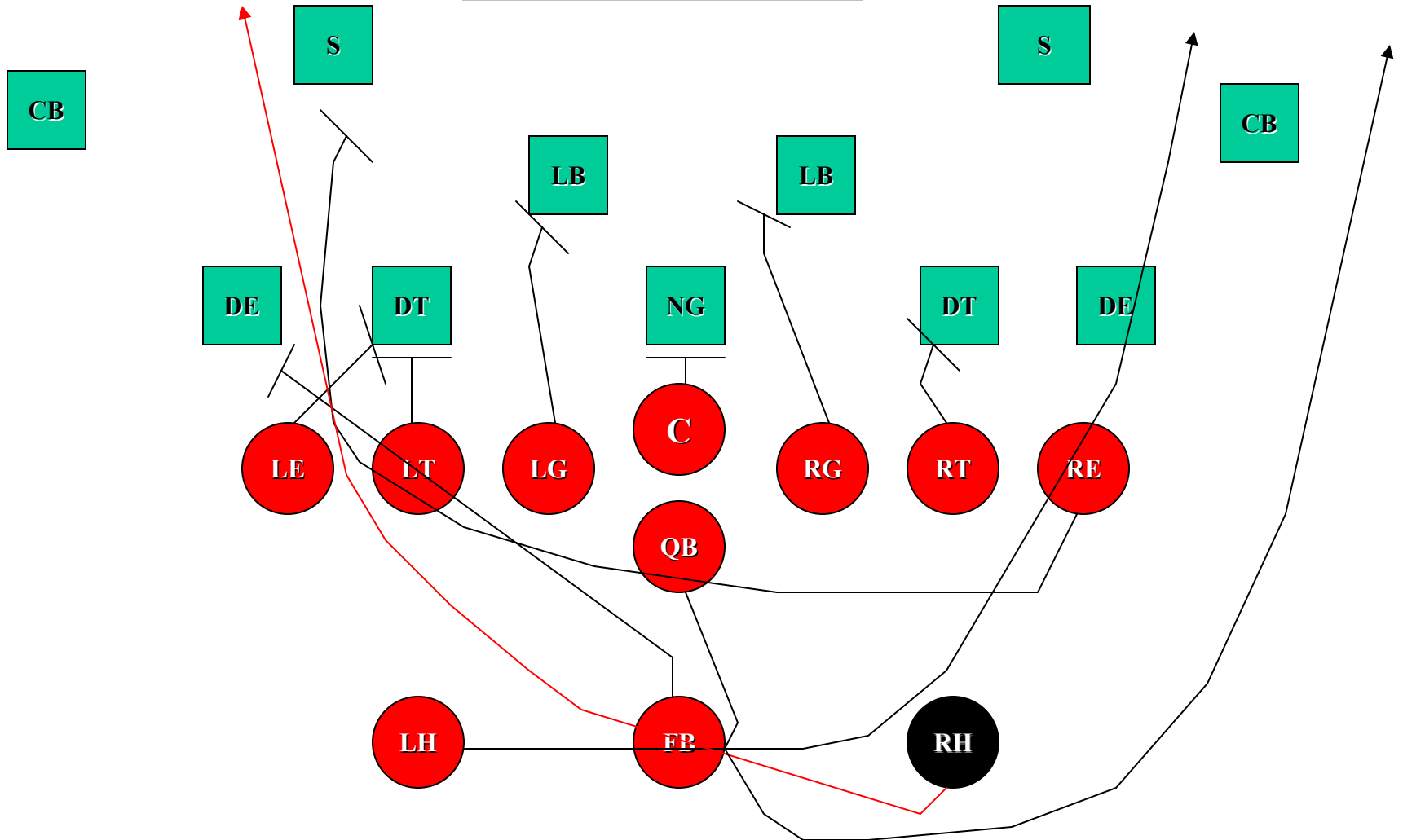

27 REVERSE SOLID VS. 5-3

DEFENSE

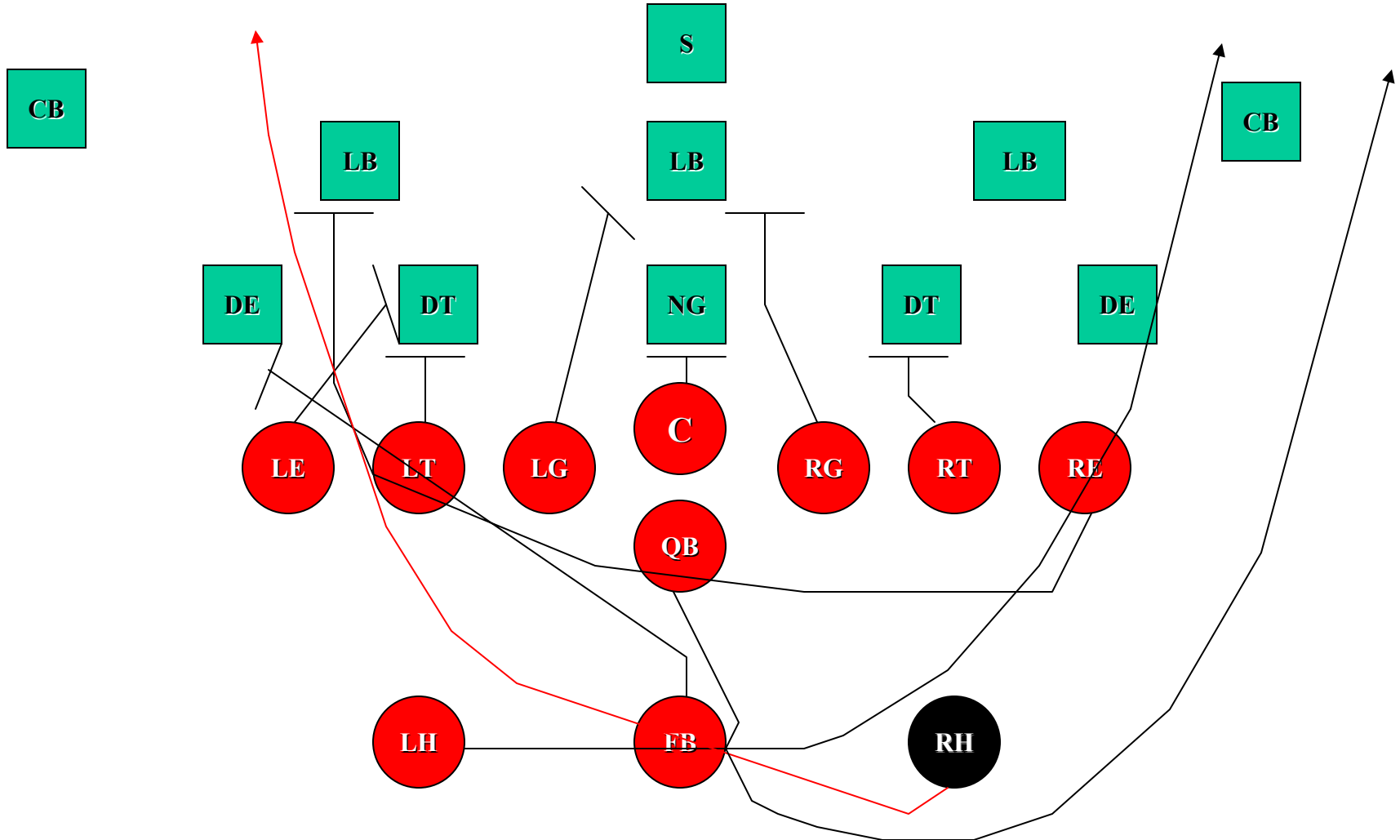

27 REVERSE SOLID VS. 7-1 DEFENSE

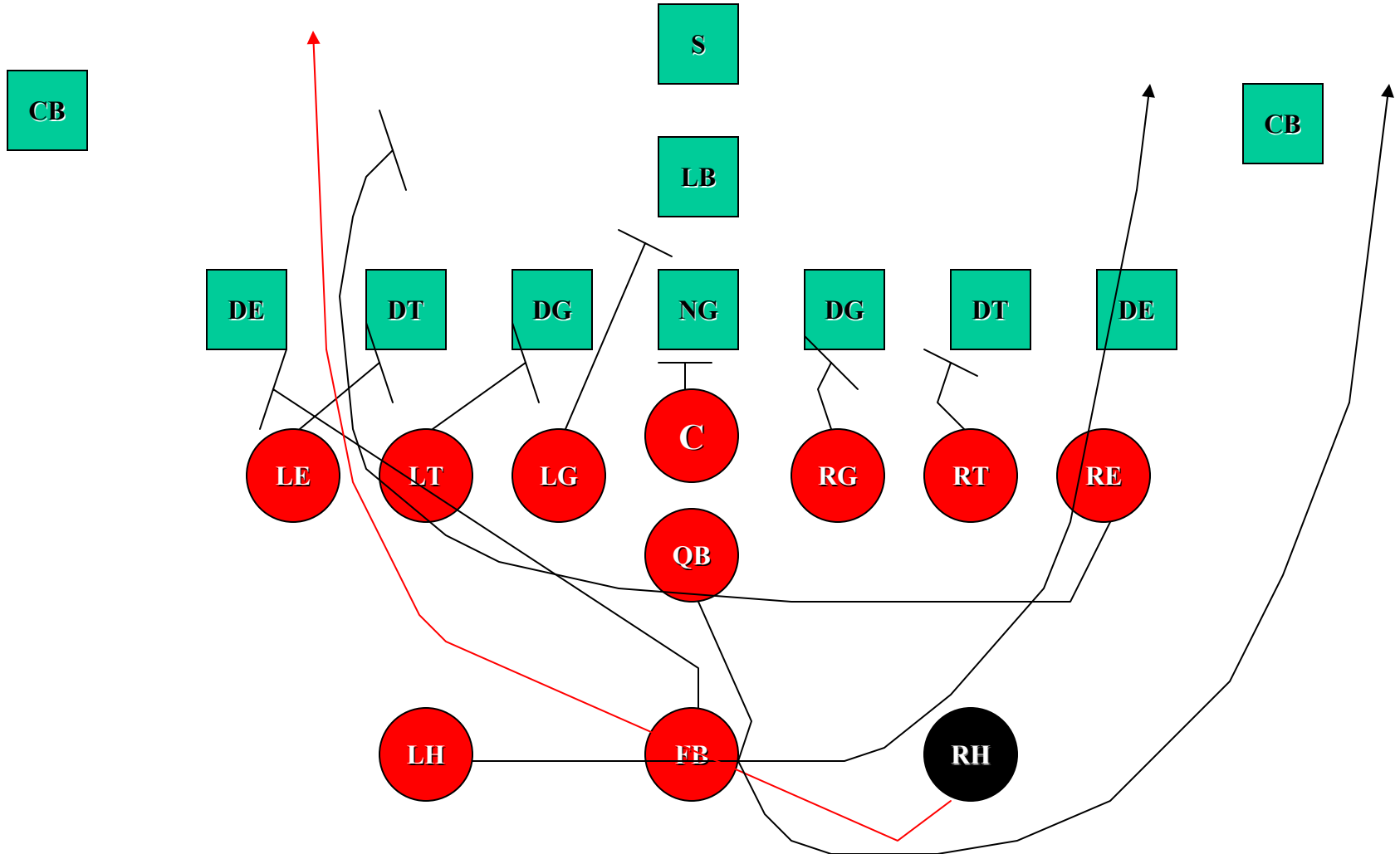

27 REVERSE SOLID VS. 6-1

DEFENSE

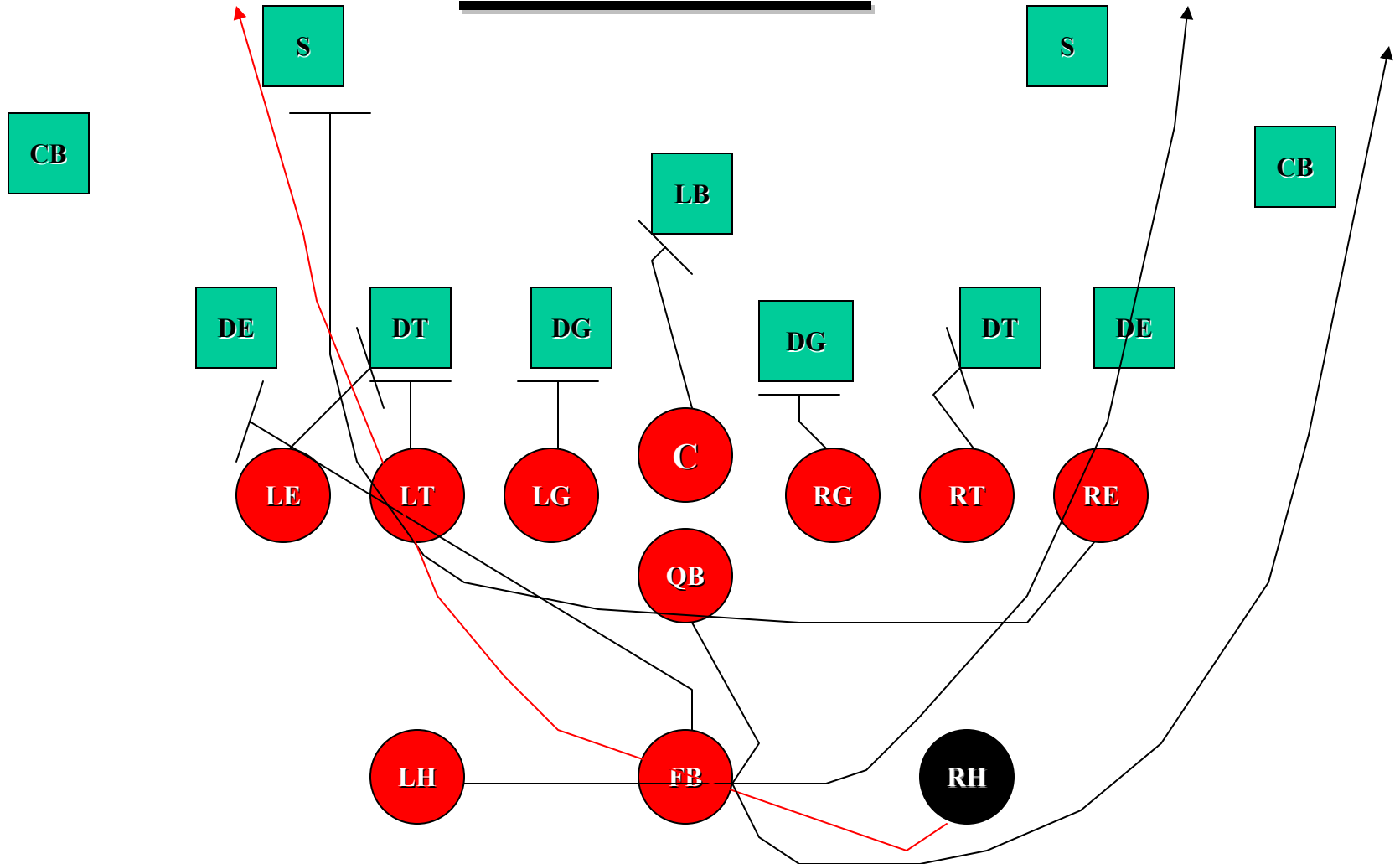

27 REVERSE SOLID VS. 6-2

DEFENSE

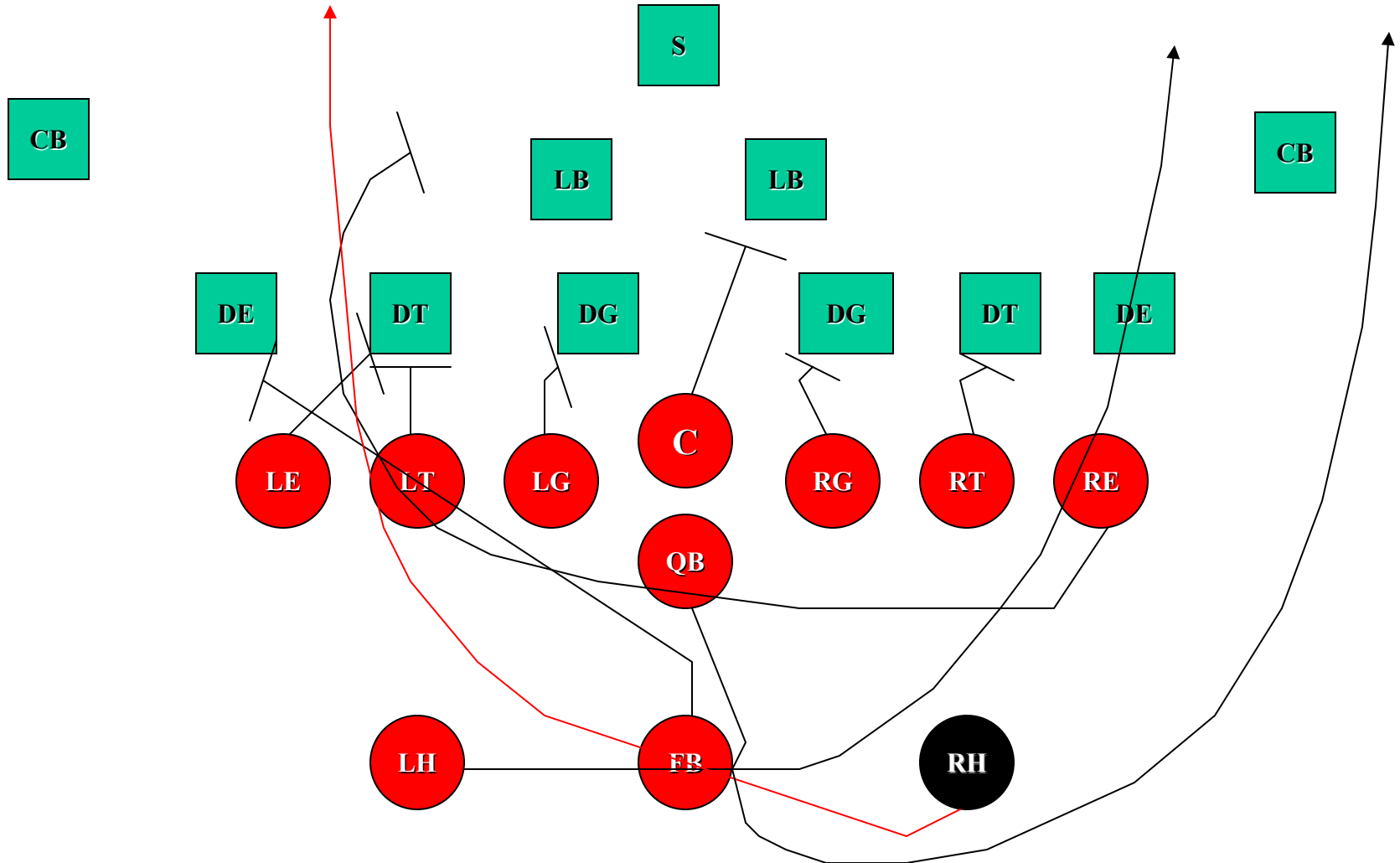

27 REVERSE SOLID VS. 6-5

DEFENSE

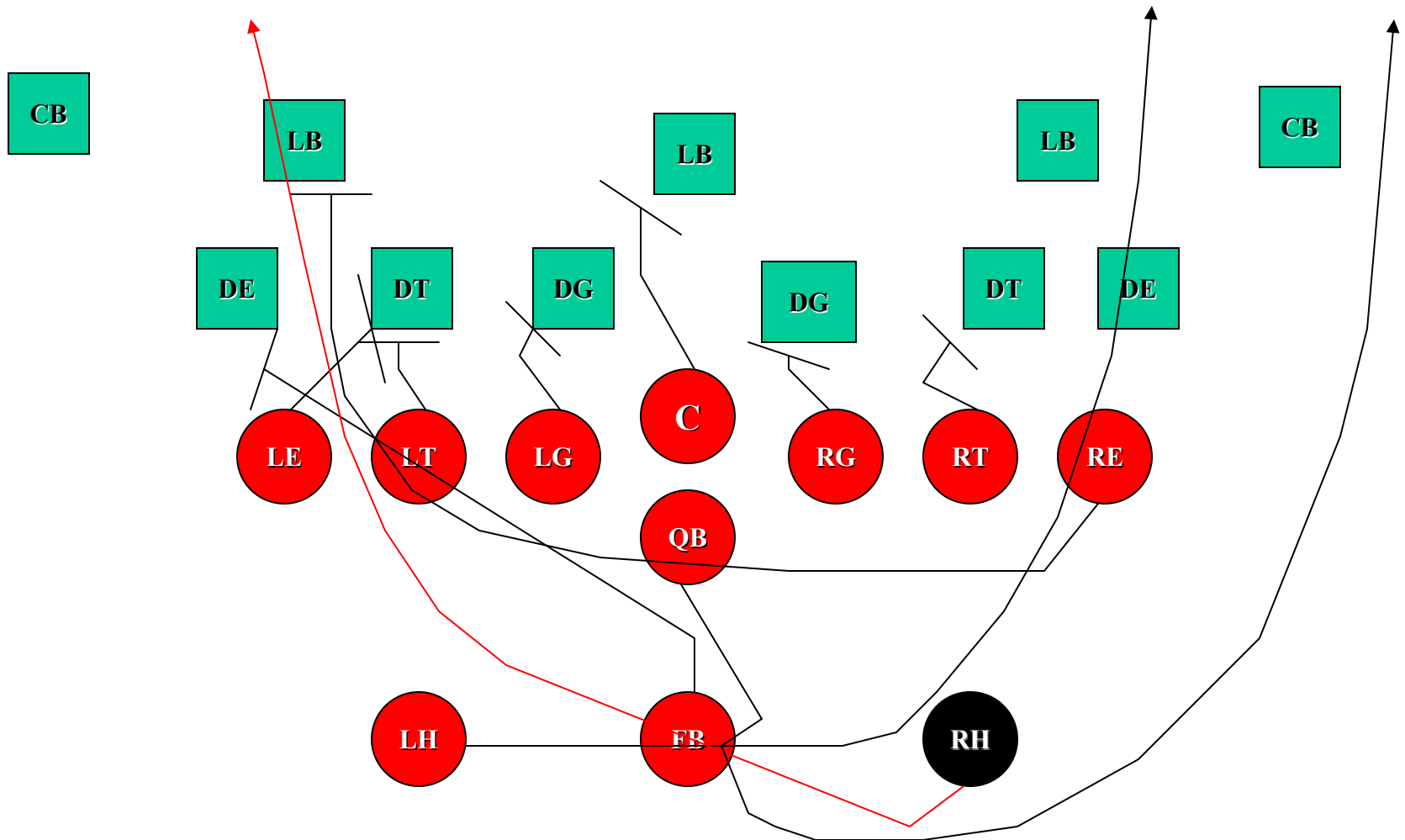

27 REVERSE SOLID VS. 4-4

DEFENSE

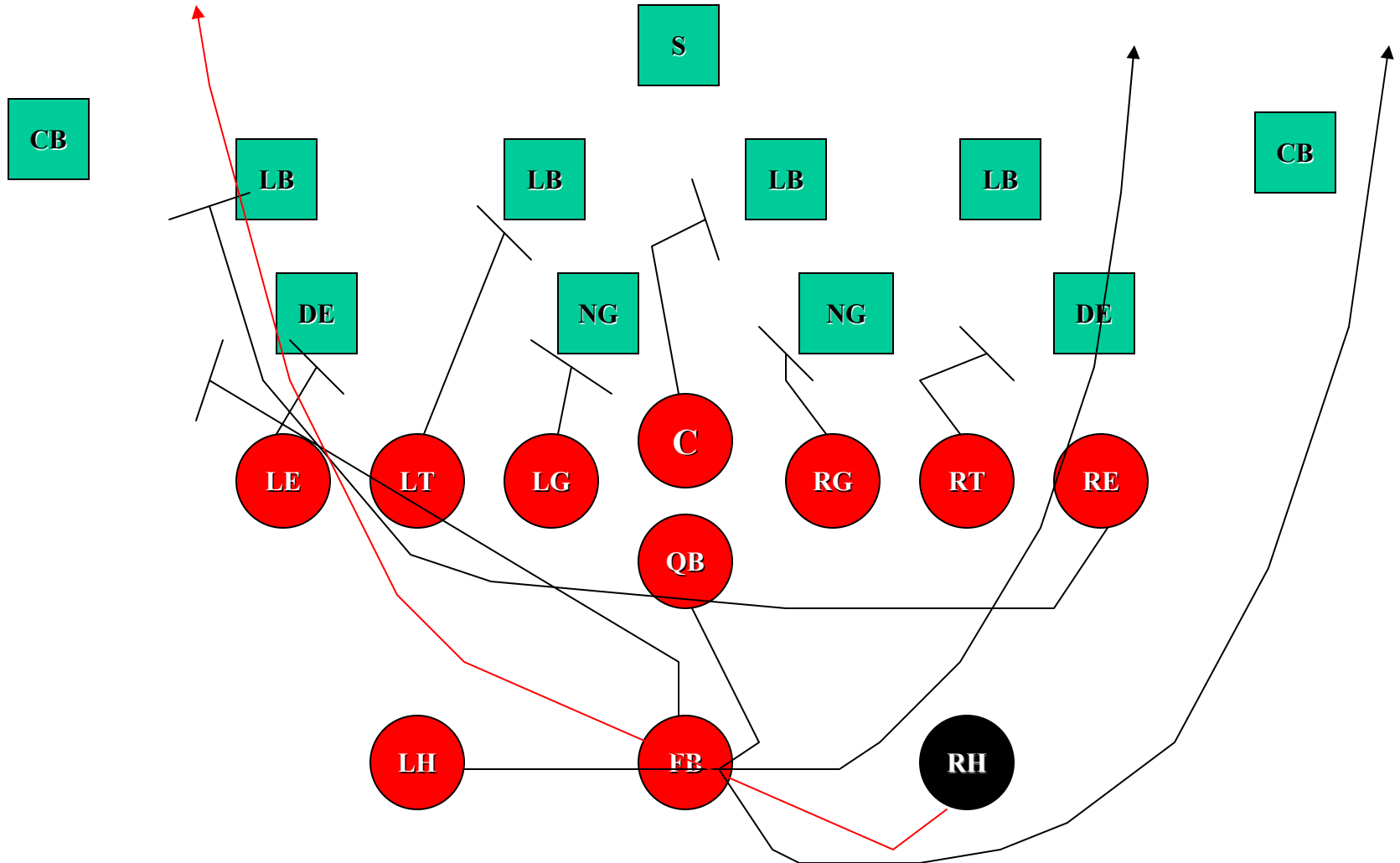

38 – 29 SWEEP

TE:

FSE: BLOCK DOWN ON THE 1ST MAN INSIDE THE DEFENSIVE END. DO NOT ALLOW PENETRATION.

BSE: TAILGATE AND HUNT.

T:

FST: BLOCK DOWN ON THE 1ST MAN INSIDE. DO NOT ALLOW PENETRATION.

BST: PULL AND PEEL ANY DEFENDER OFF THE PULLING GUARD. THEN HUNT.

G:

FSG: PULL WITH A LEAD STEP AND BLOCK THE PRIMARY FORCE. HOOK OR KICK OUT.

BSG: PULL WITH A LEAD STEP AND ON YOUR THIRD STEP GET 18" DEEPER THAN THE FSG. READ HIS BLOCK ON THE FORCE.

C:

VS. ODD – LEAD PLAYSIDE VS. 1&2 TECHNIQUES. VS. "ZERO" GO BEYOND THE PS SHOULDER.

VS. EVEN- BLOCK THE MOST DANGEROUS SHIRT BACKSIDE.

QB:

PIVOT ON PLAYSIDE FOOT. PUSH BALL BACK TO HB ON 2ND STEP. THEN FAKE BOOT.

RUN OUTSIDE THE WIDEST DEFENDER. SELL FAKE FOR 20 YARDS.

FB:

STEP FORWARD WITH PS FOOT AND MAKE A PROXIMITY FAKE WITH THE QB. POCKET AND ROCK THE CRADLE.

RUN INTO THE FRONT SIDE B-GAP LOOKING FOR AN UGLY SHIRT.

HB:

FSH: LINE UP IN A WING AND BLOCK DOWN ON THE D-END. DO NOT ALLOW HIM TO PENETRATE.

BSH: LEAD STEP TO FAR SIDE LINE, POCKET AND RECEIVE BALL FROM QB. READ FSG BLOCK. KEEP BALL WRAPPED.



238 SWEEP VS. 5-2 DEFENSE

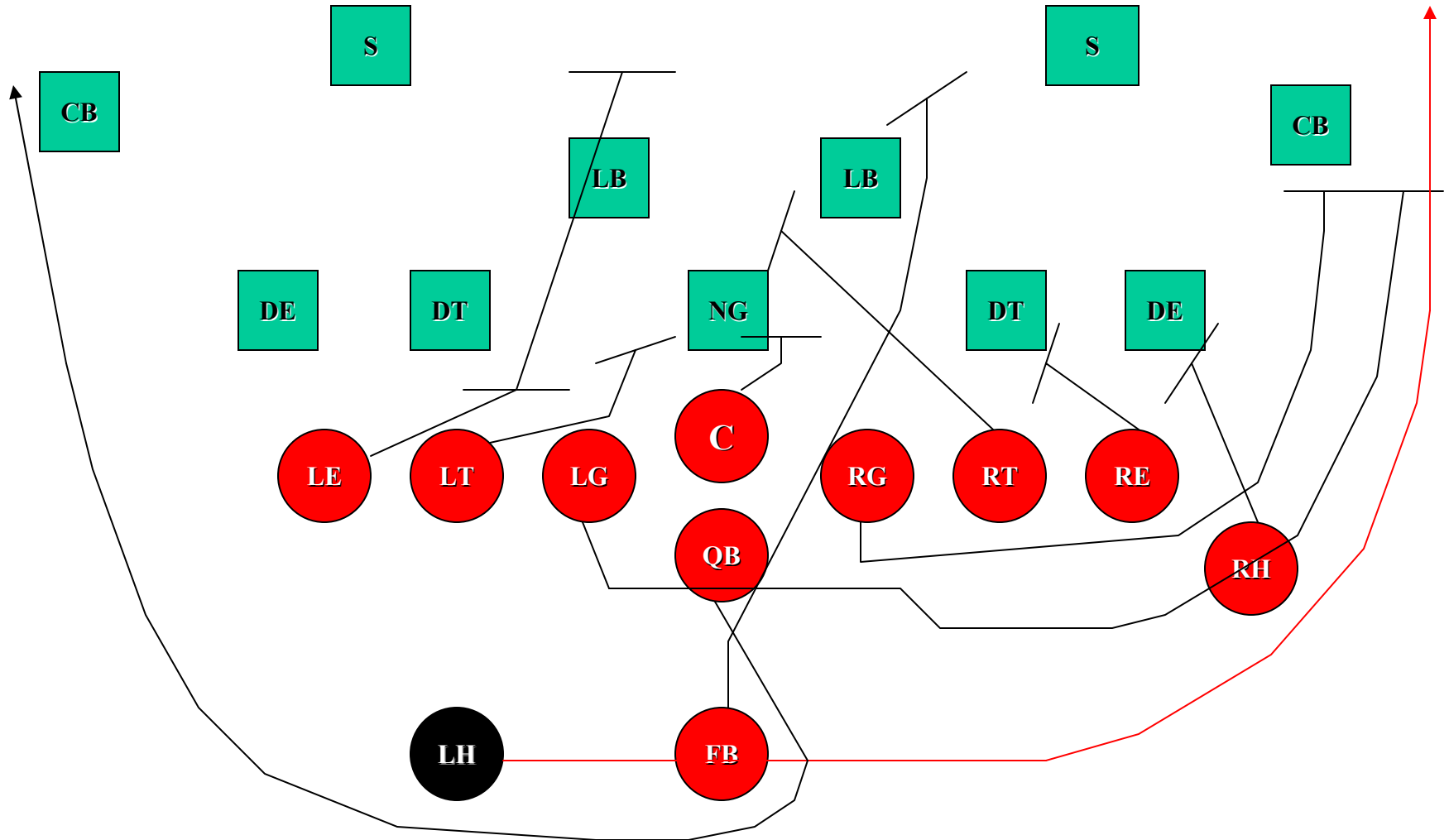

238 SWEEP VS. 5-3 DEFENSE

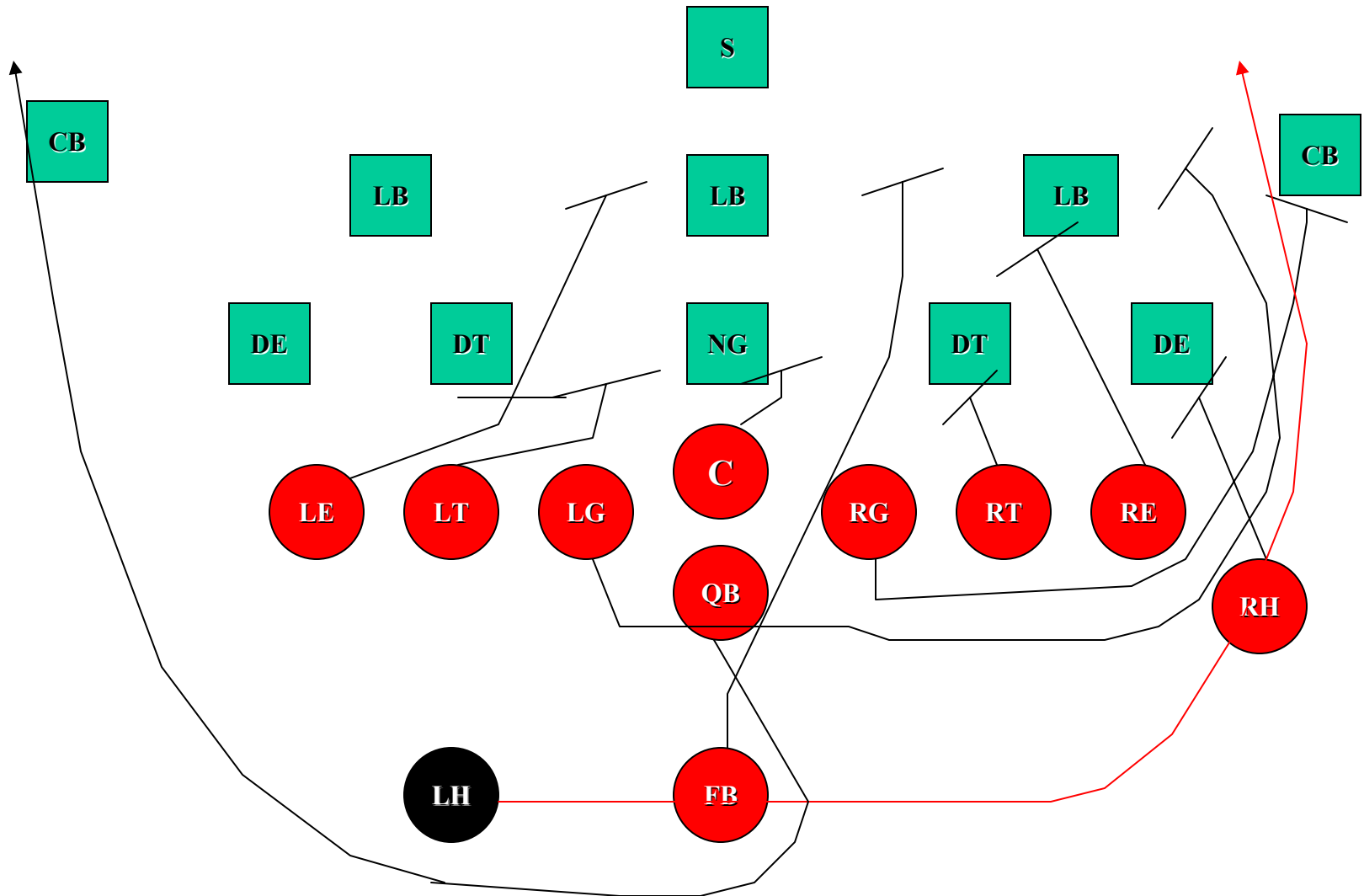

238 SWEEP VS. 7-1 DEFENSE

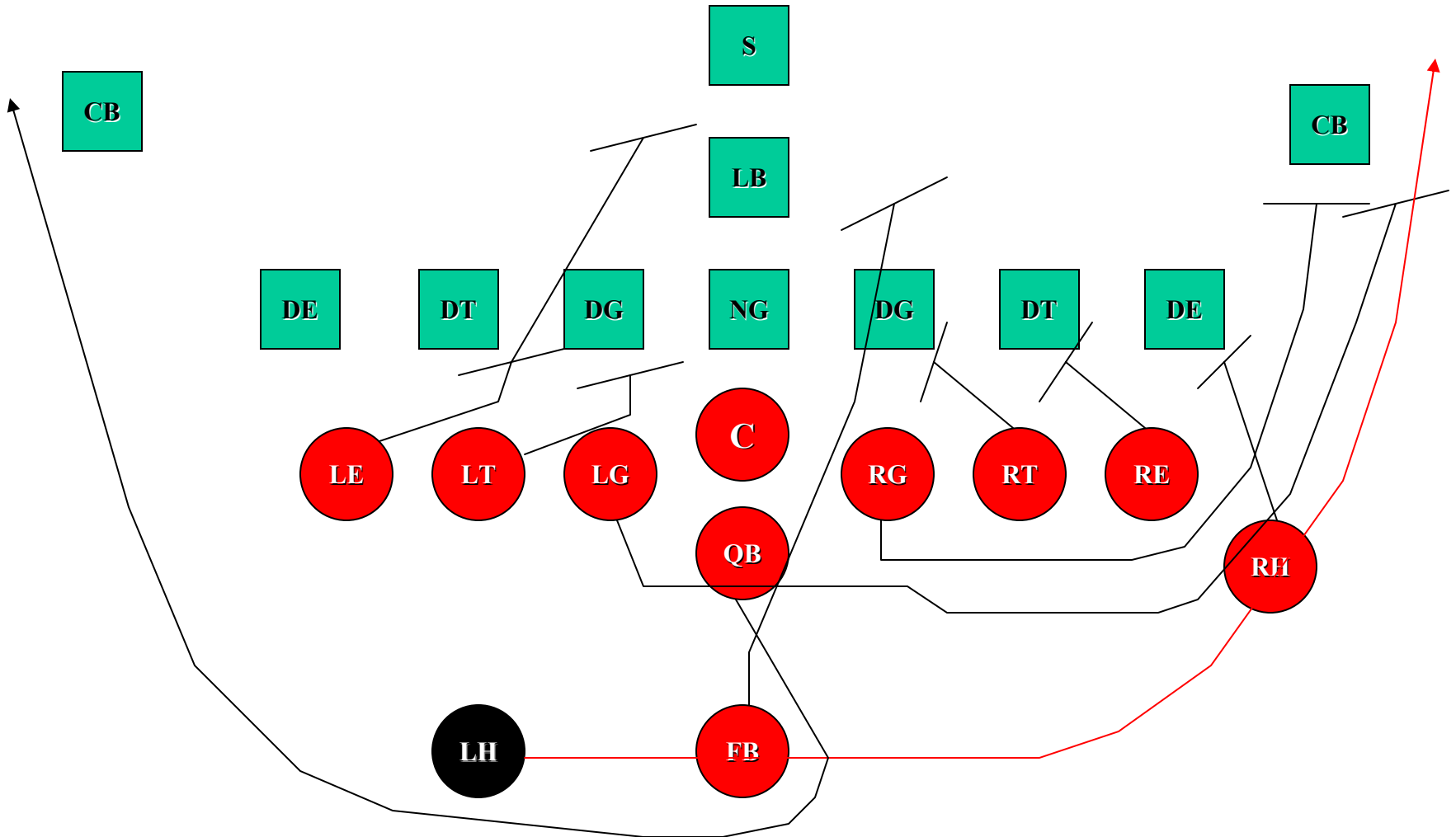

238 SWEEP VS. 6-1 DEFENSE

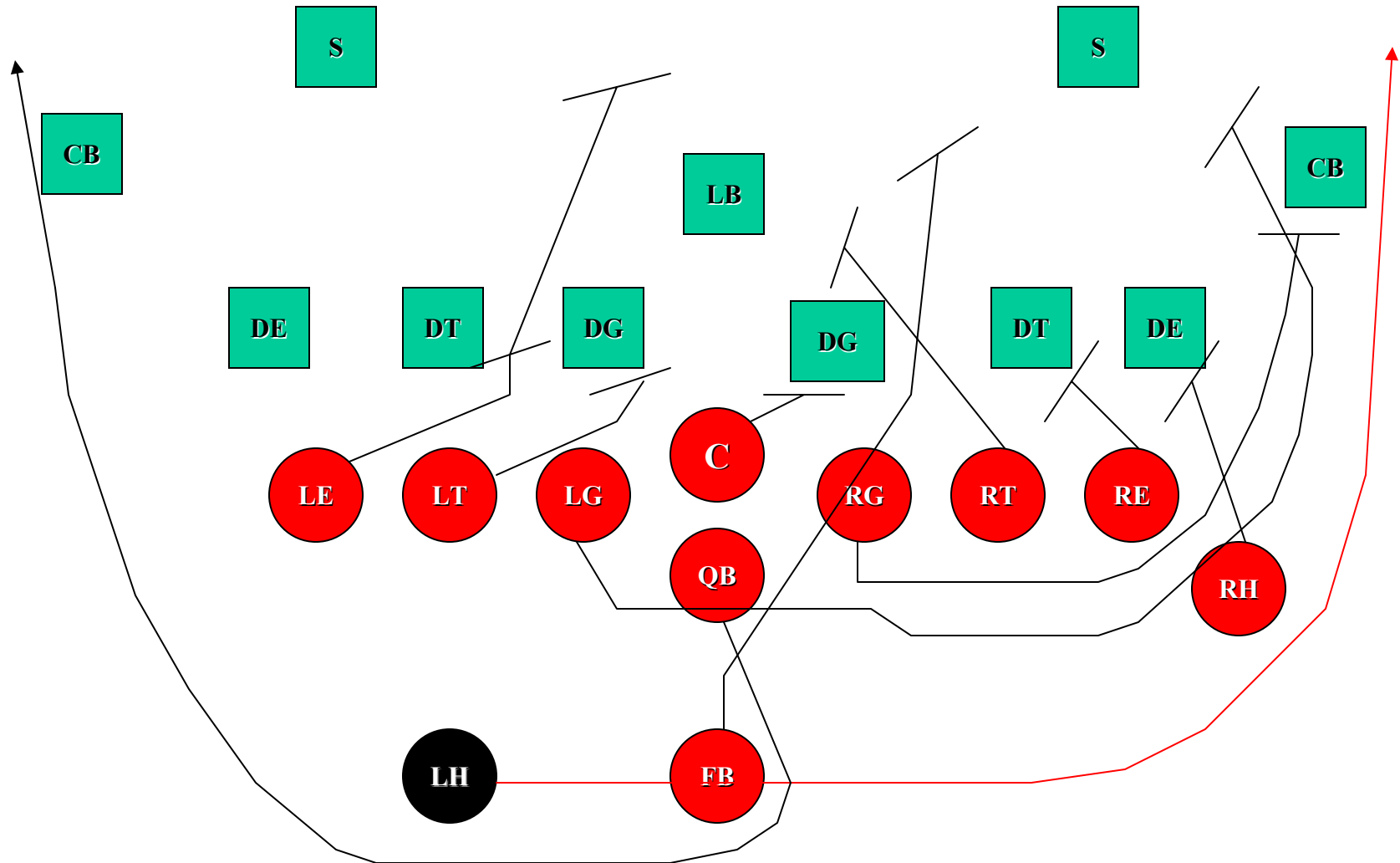

238 SWEEP VS. 6-2 DEFENSE

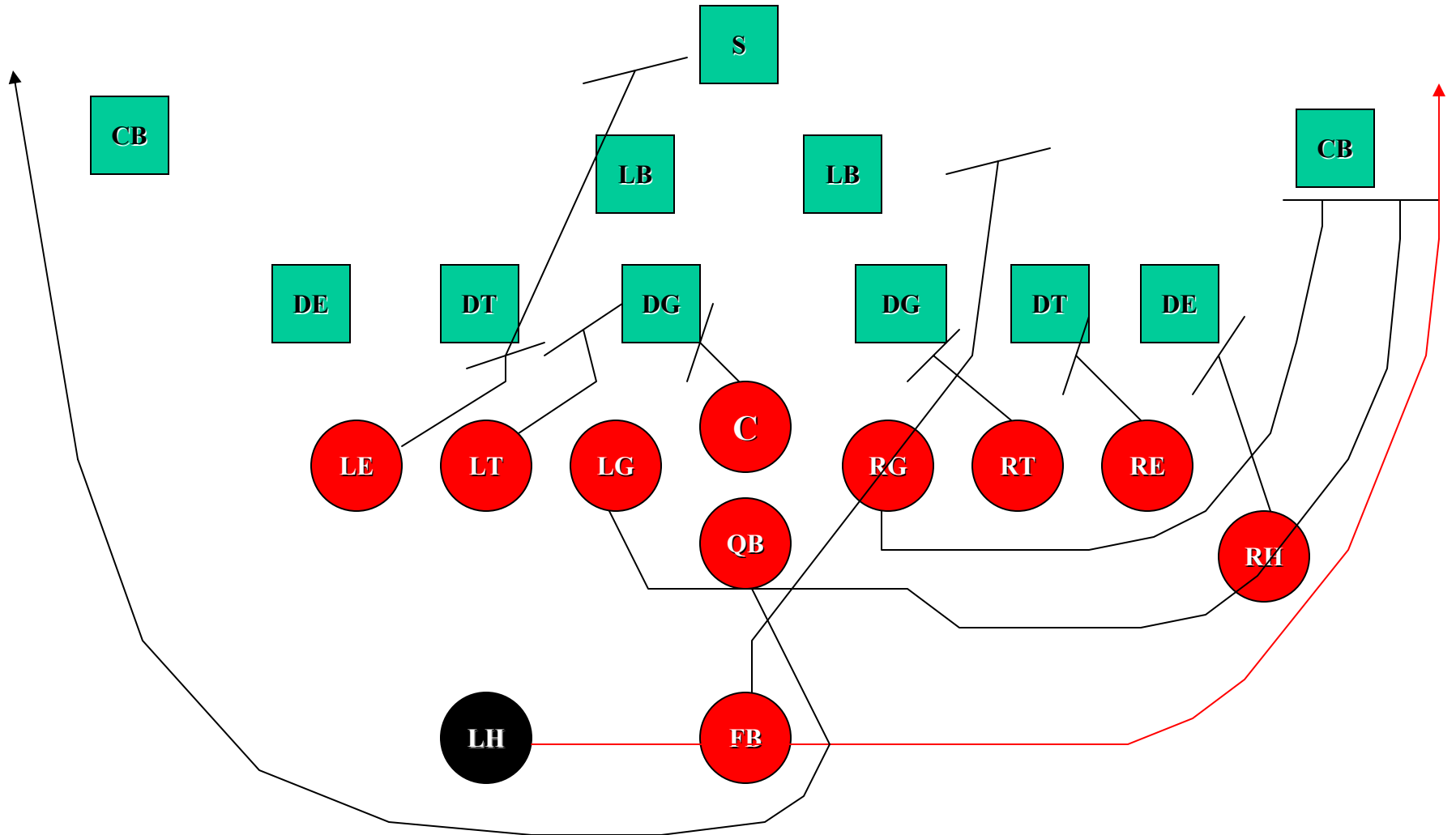

238 SWEEP VS. 6-5 DEFENSE

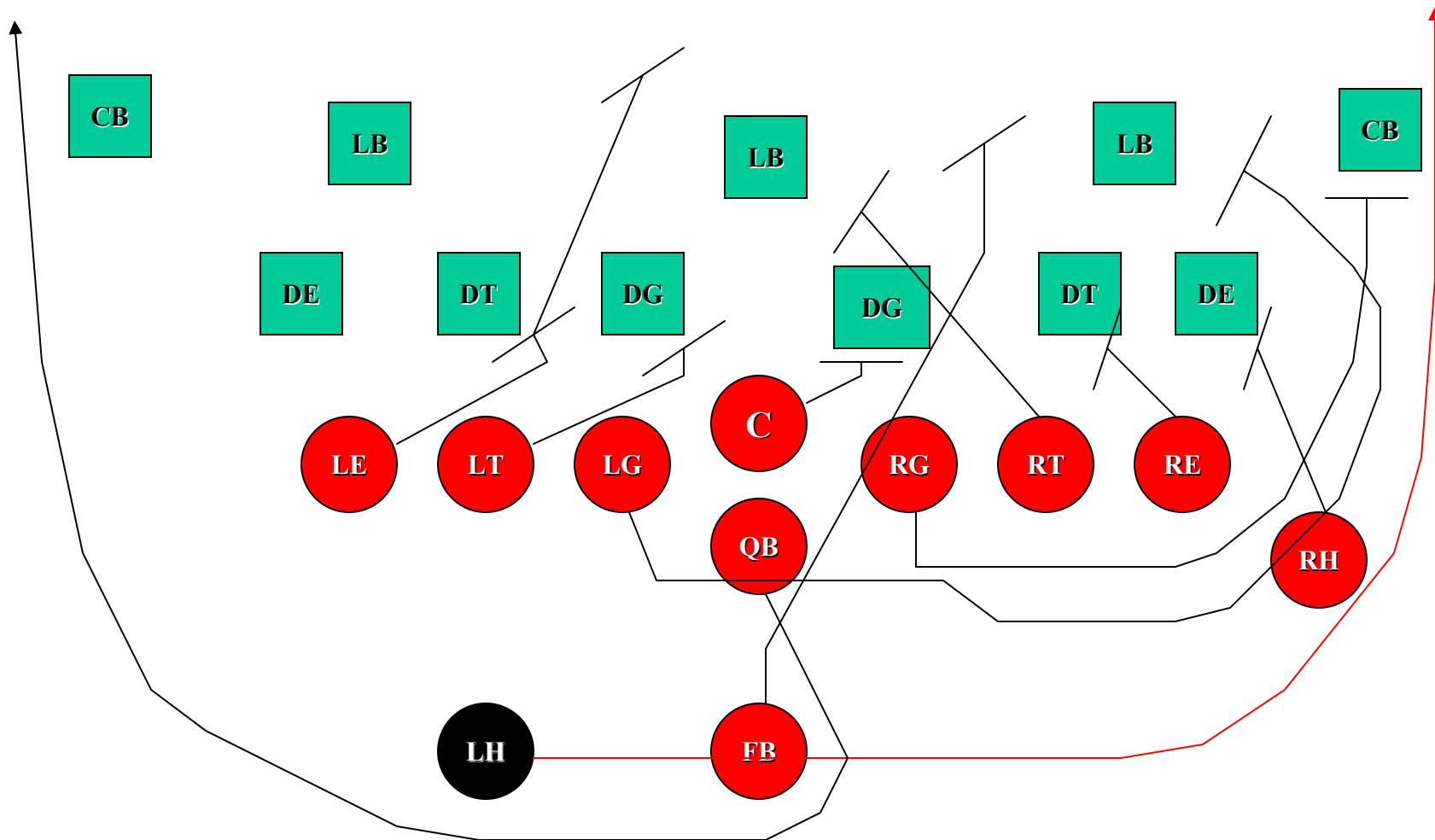

238 SWEEP VS. 4-3 DEFENSE

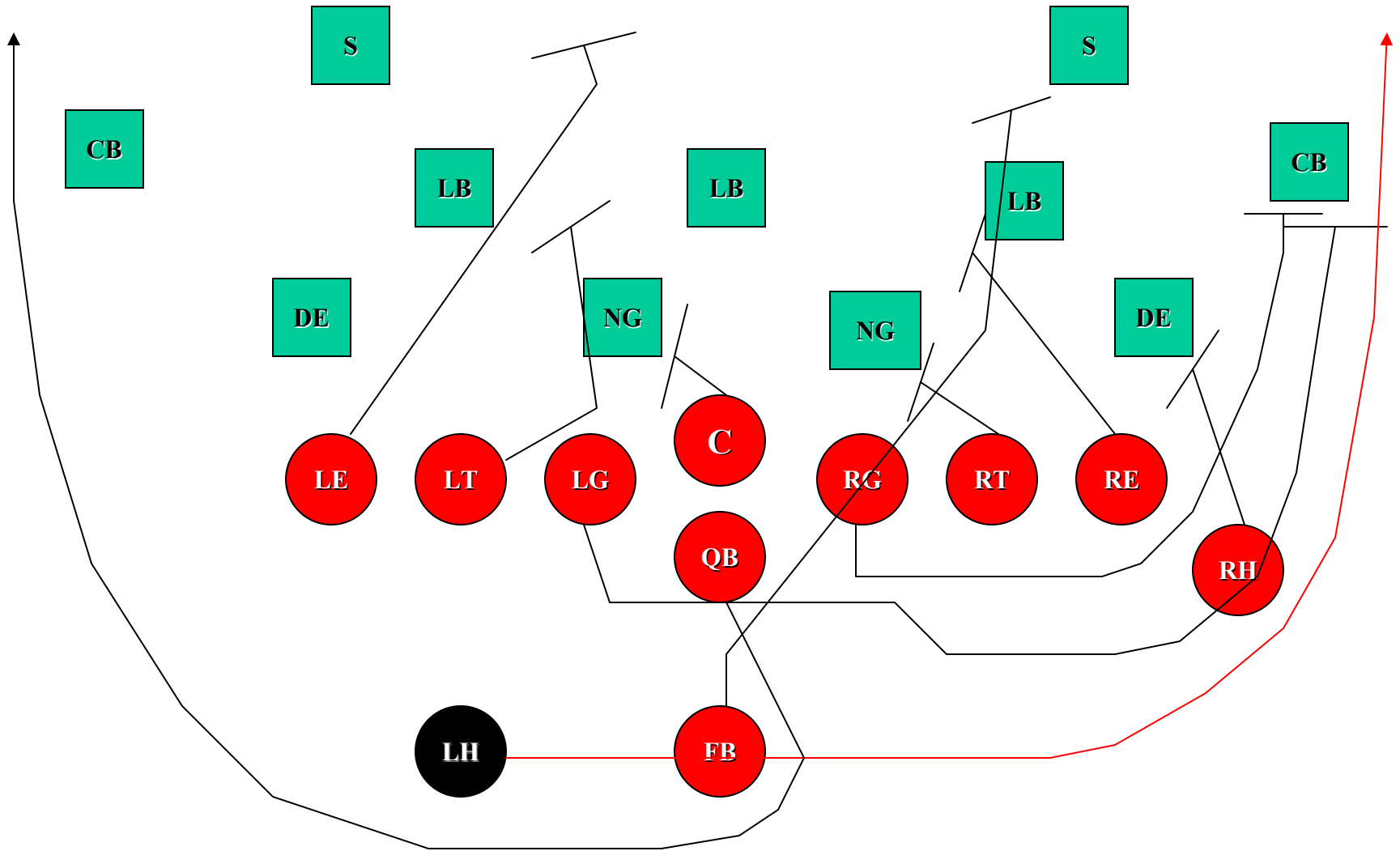

238 SWEEP VS. 4-4 DEFENSE

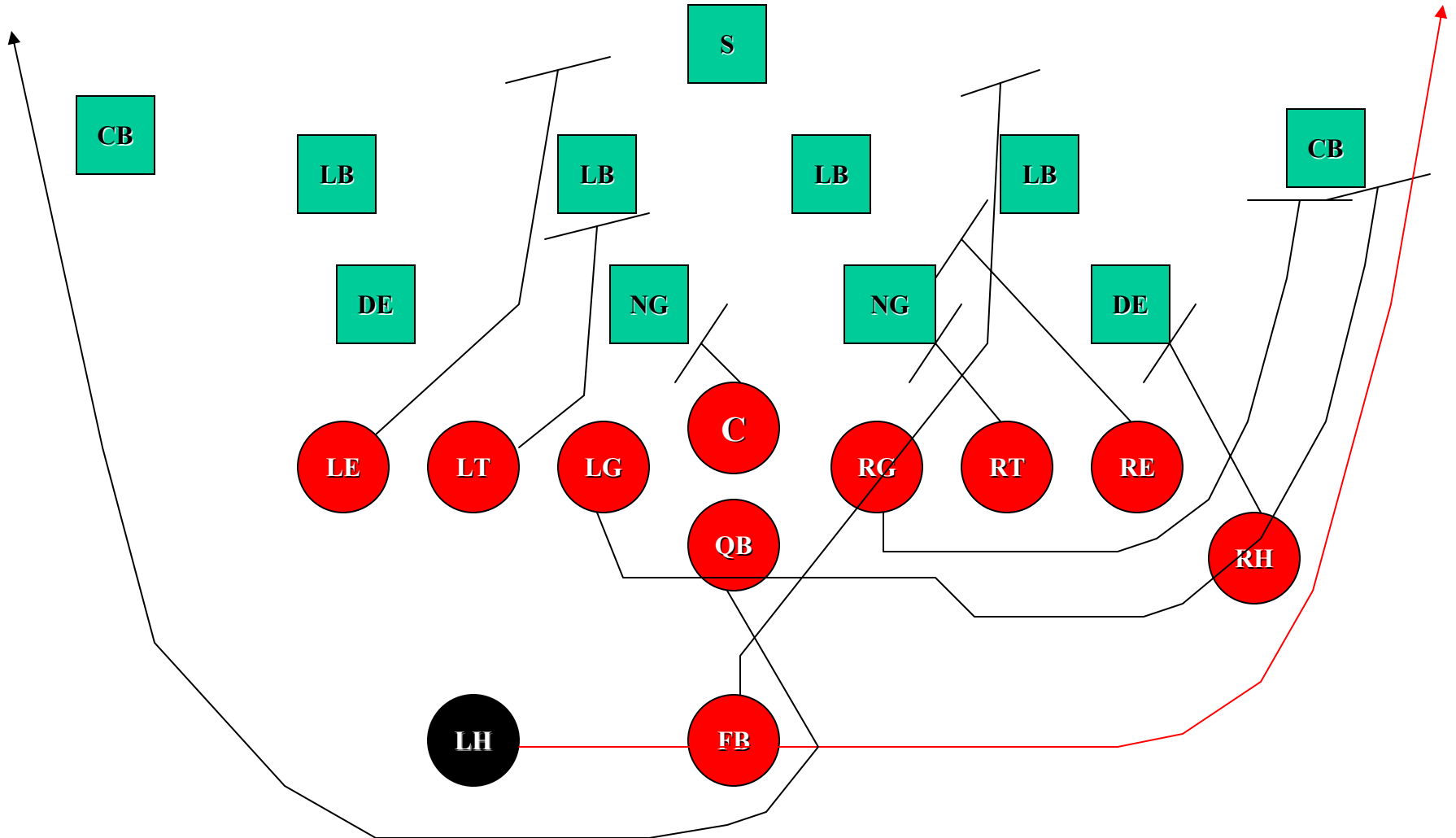

38 – 29 POWER SWEEP

TE:

FSE: BLOCK THE 3RD MAN OUTSIDE THE CENTER. APPLY STACK RULES.

BSE: TAILGATE AND HUNT.

T:

FST: BLOCK THE 2ND MAN OUTSIDE THE CENTER. APPLY STACK RULES.

BST: PULL AND PEEL ANY DEFENDER OFF THE PULLING GUARD. THEN HUNT.

G:

FSG: BLOCK THE 1ST MAN OUTSIDE CENTER. APPLY STACK RULES.

BSG: PULL WITH A LEAD STEP. AFTER FIRST STEP DEEPEN 18". READ FB'S BLOCK ON THE FORCE. BLOCK NEXT UGLY SHIRT TO SHOW.

C:

VS. ODD – GO BEYOND THE PLAYSIDE SHOULDER VS. NG. LEAD PS VS. 1 TECHNIQUES.

VS. EVEN – BLOCK THE MOST DANGEROUS SHIRT BACKSIDE.

QB:

PIVOT ON PLAYSIDE FOOT. PUSH BALL BACK TO HB ON 2ND STEP. THEN FAKE BOOT.

RUN OUTSIDE THE WIDEST DEFENDER. CARRY OUT FAKE FOR AT LEAST 20 YARDS.

FB:

STEP LATERAL FOR THREE STEPS. THEN PUSH UPFIELD AND BLOCK PRIMARY FORCE.

KICK OUT A FORCE OR HOOK A HANGER.

HB:

FSH: LINE UP IN A WING AND BLOCK DOWN ON THE D-END. DO NOT ALLOW HIM TO PENETRATE.

BSH: LEAD STEP TO FAR SIDE LINE, POCKET AND RECEIVE BALL FROM QB. READ FB'S BLOCK. KEEP BALL WRAPPED.



238 POWER VS. 5-2

DEFENSE

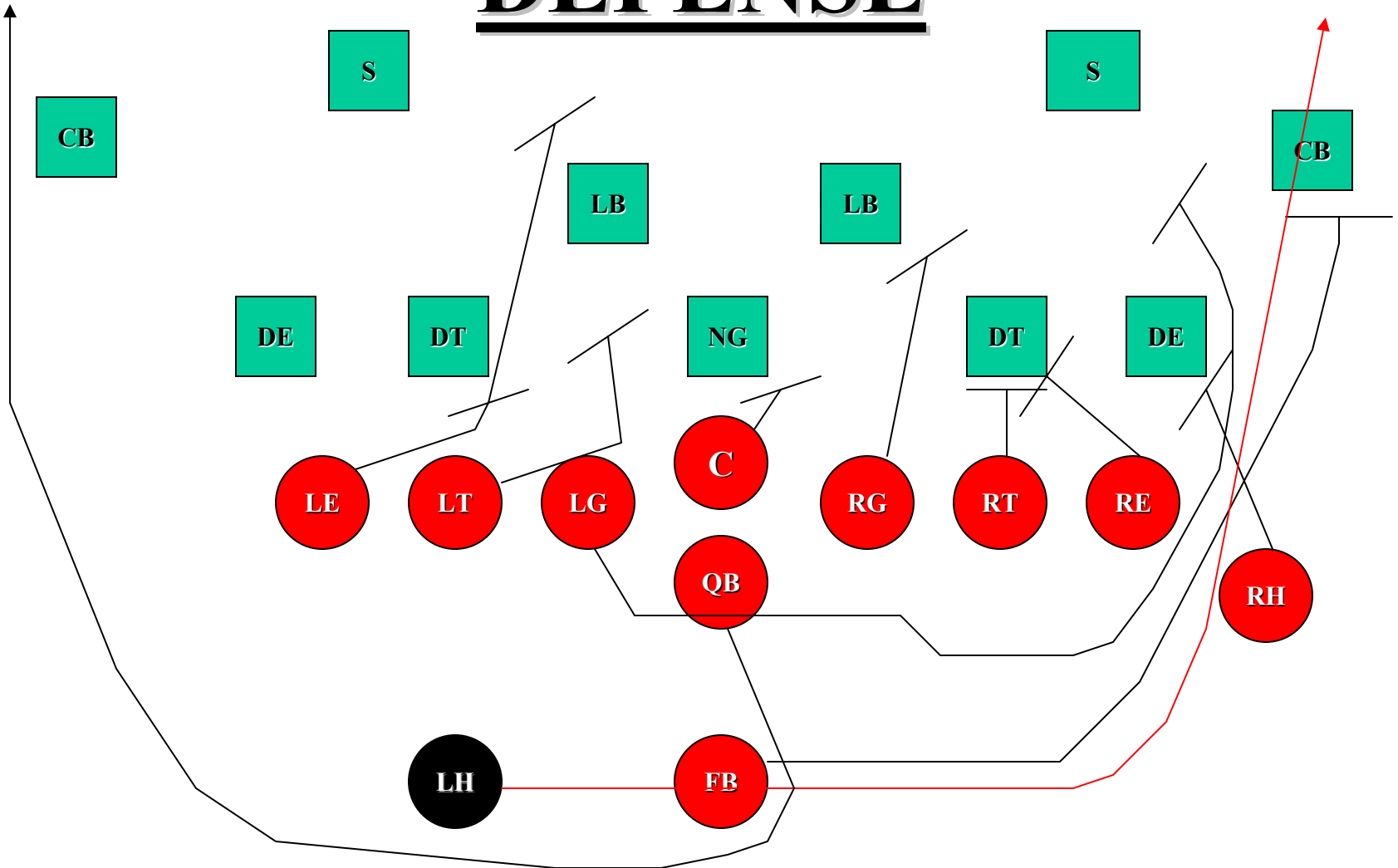

238 POWER VS. 7-1

DEFENSE

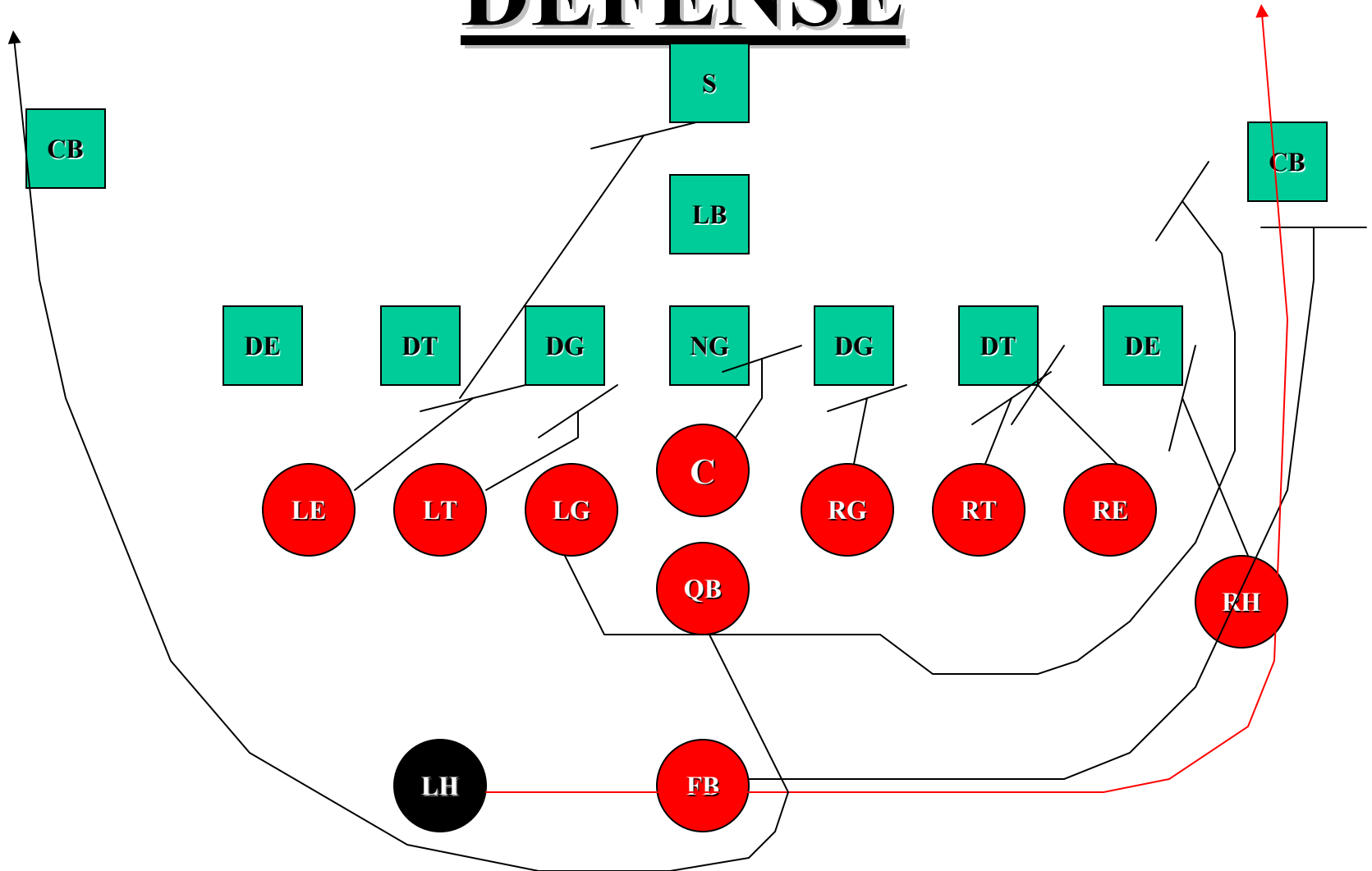

238 POWER VS. 6-1

DEFENSE

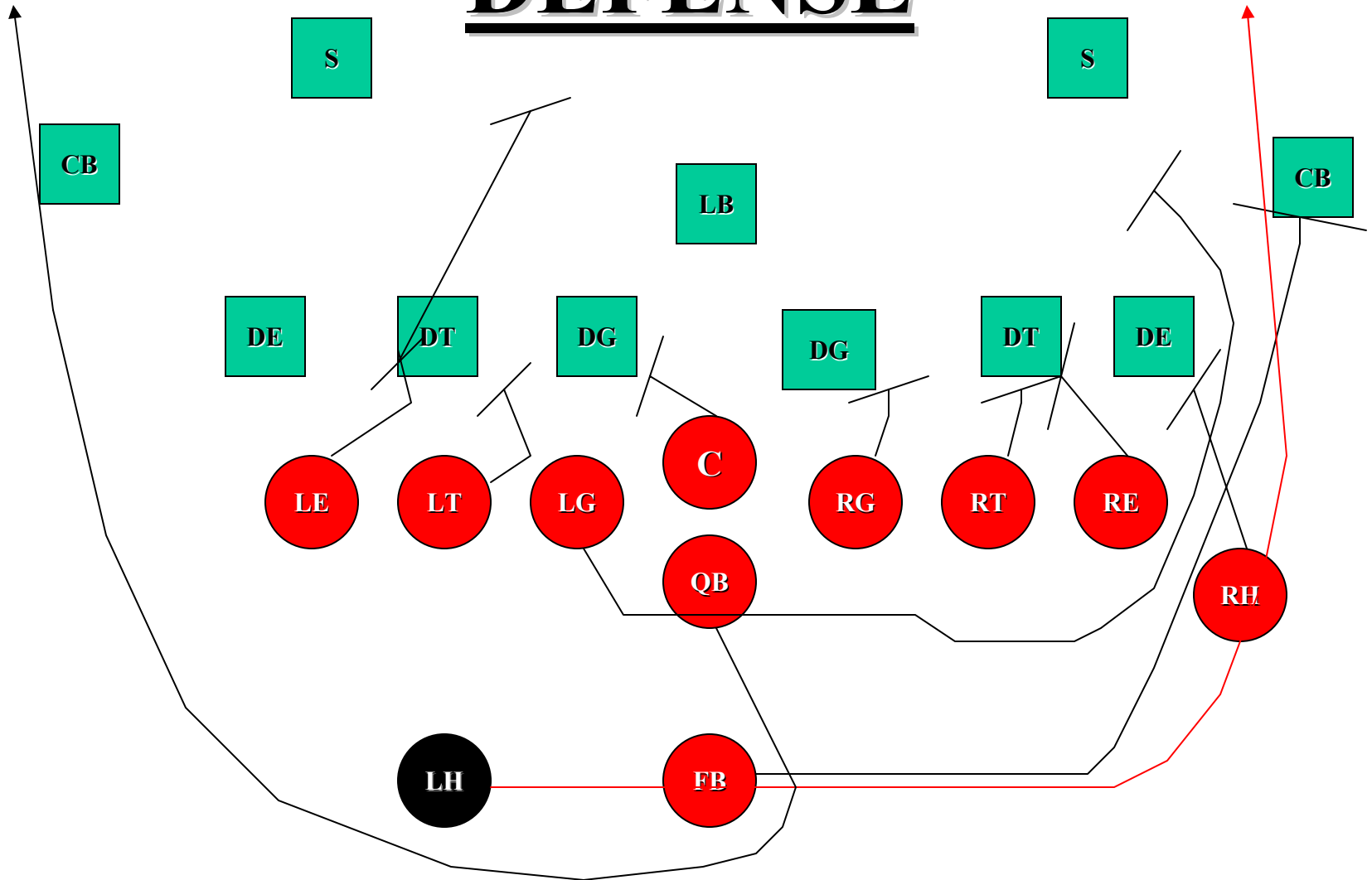

238 POWER VS. 6-2

DEFENSE

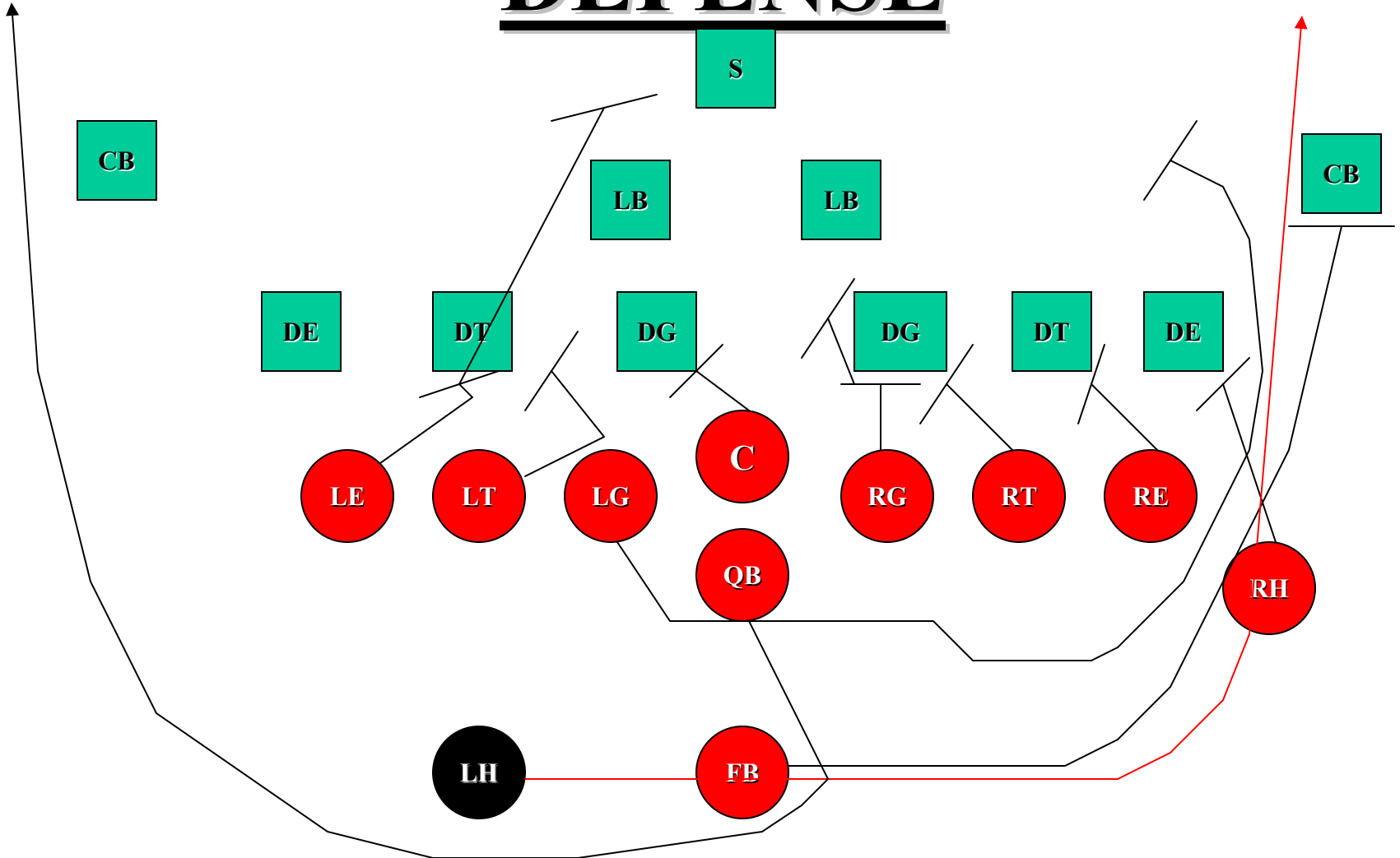

238 POWER VS. 6-5

DEFENSE

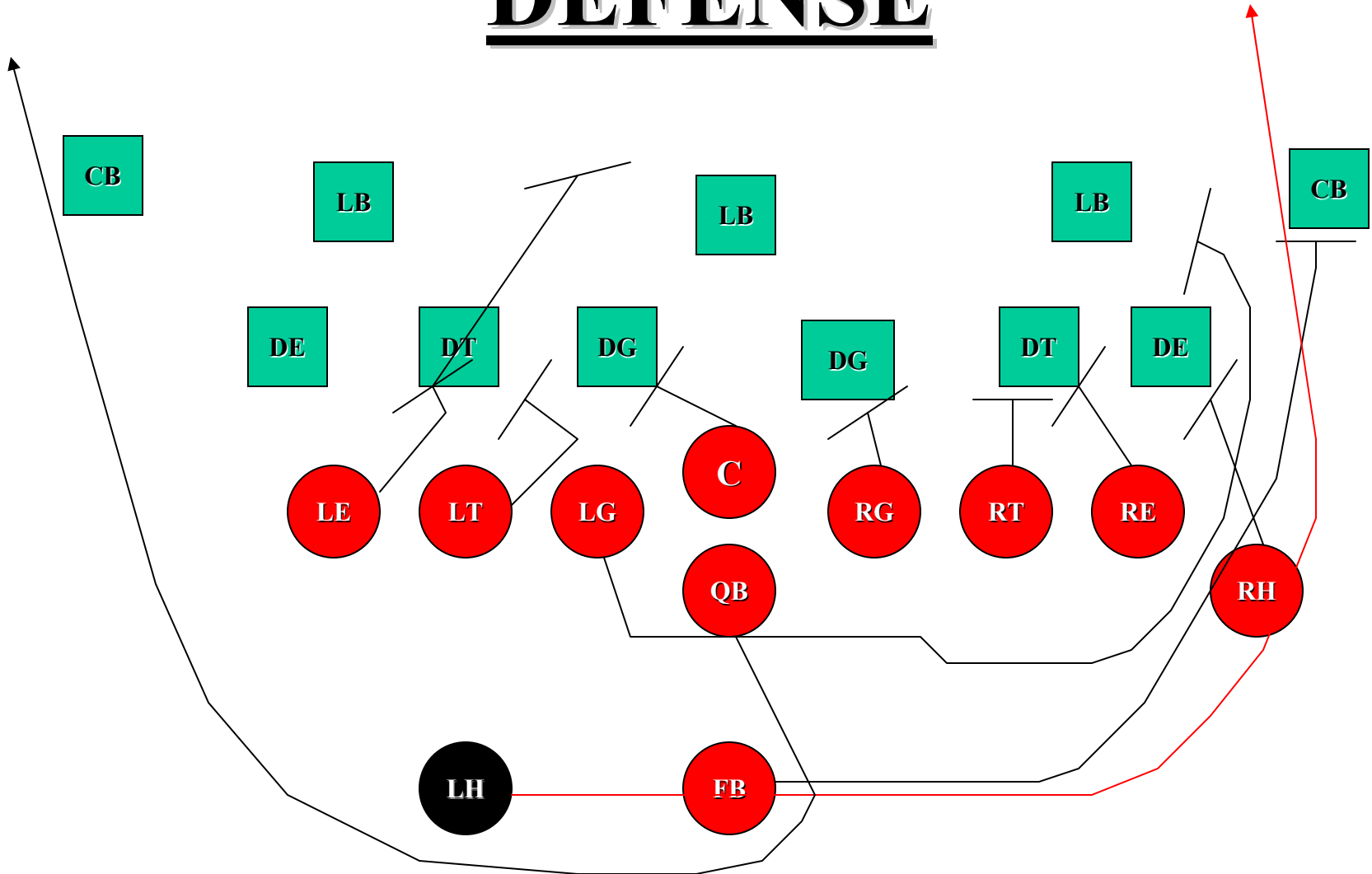

238 POWER VS. 4-3

DEFENSE

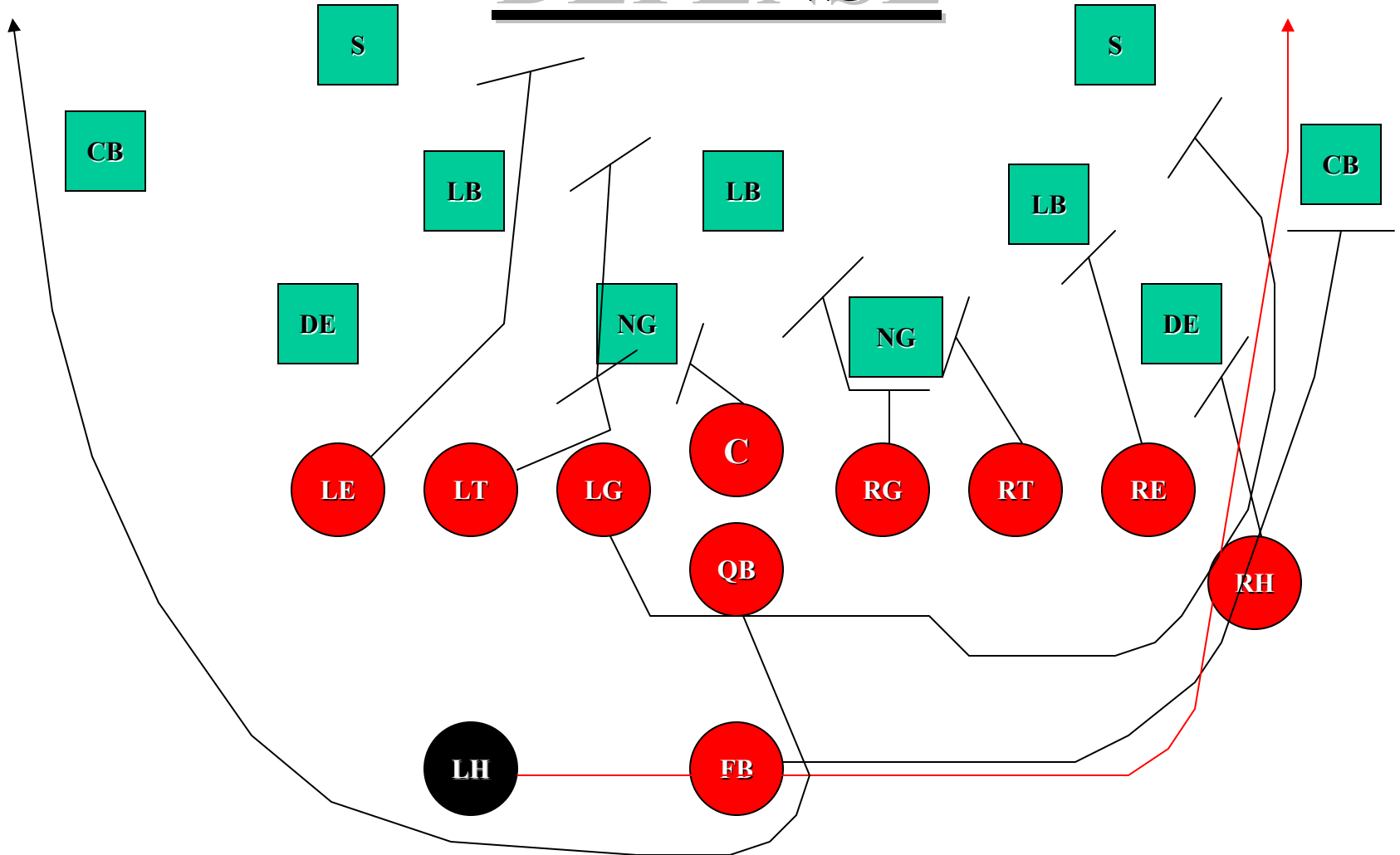

238 POWER VS. 4-4

DEFENSE

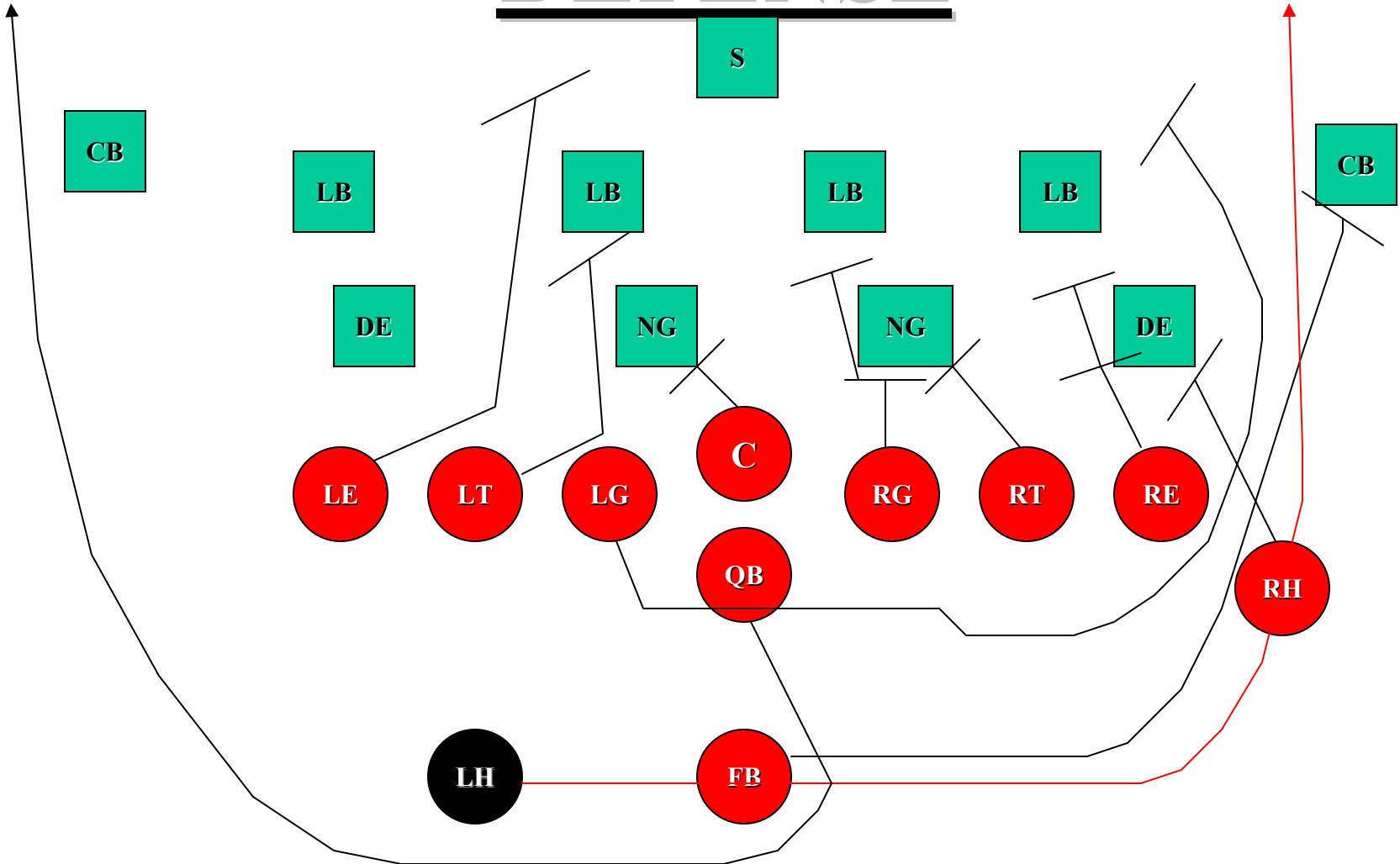

38 – 29 HALF REVERSE

TE:

FSE: BLOCK THE 3RD MAN
OUTSIDE CENTER. APPLY STACK
RULES.

BSE: BLOCK SOLID ON #3.
OUTSIDE CENTER.

T:

FST: BLOCK THE 2ND MAN
OUTSIDE THE CENTER. APPLY
STACK RULES.

BST: BLOCK SOLID ON #2.
OUTSIDE CENTER. VS 1-2 STACK
CO-OP W/CENTER.

G:

FSG: BLOCK THE 1ST MAN
OUTSIDE CENTER. APPLY STACK
RULES.

BSG: LEAD STEP BACKSIDE
THEN PIVOT 180* ON 2ND STEP.
READ QB'S BLOCK ON FORCE
AND BLOCK NEXT DANGEROUS
SHIRT.

C:

VS. ODD – BLOCK NG. BLOCK A 1
TECHNIQUE IF ABLE. OR
IDENTIFY HIM AS #1.

VS. EVEN – BLOCK THE MOST
DANGEROUS SHIRT BACKSIDE.

QB:

PIVOT ON PLAYSIDE FOOT. PUSH
BALL BACK TO HB ON 2ND STEP.
THEN BOOT BACKSIDE.

BLOCK THE PRIMARY FORCE.
KICKOUT A FORCE OR HOOK A
HANGER.

FB:

STEP FORWARD WITH BACKSIDE
FOOT AND MAKE A PROXIMITY
FAKE W/QB. POCKET AND ROCK
THE CRADLE.

RUN INTO THE BACKSIDE B-GAP
LOOKING FOR AN UGLY SHIRT
TO BLOCK.

HB:

FSH: LEAD STEP TO FAR
SIDELINE, POCKET AND RECEIVE
BALL FROM QB. THEN GIVE
OUTSIDE EXCHANGE W/ BSH
AND CONTINUE TO RUN OUTSIDE
WIDEST DEFENDER FOR 20
YARDS.

BSH: DROP STEP AND MAKE
OUTSIDE EXCHANGE WITH FSH.
READ THE QB'S BLOCK AND
FOLLOW THE PULLING GUARD
AROUND THE END.

229 HALF REVERSE VS. 5-3

DEFENSE

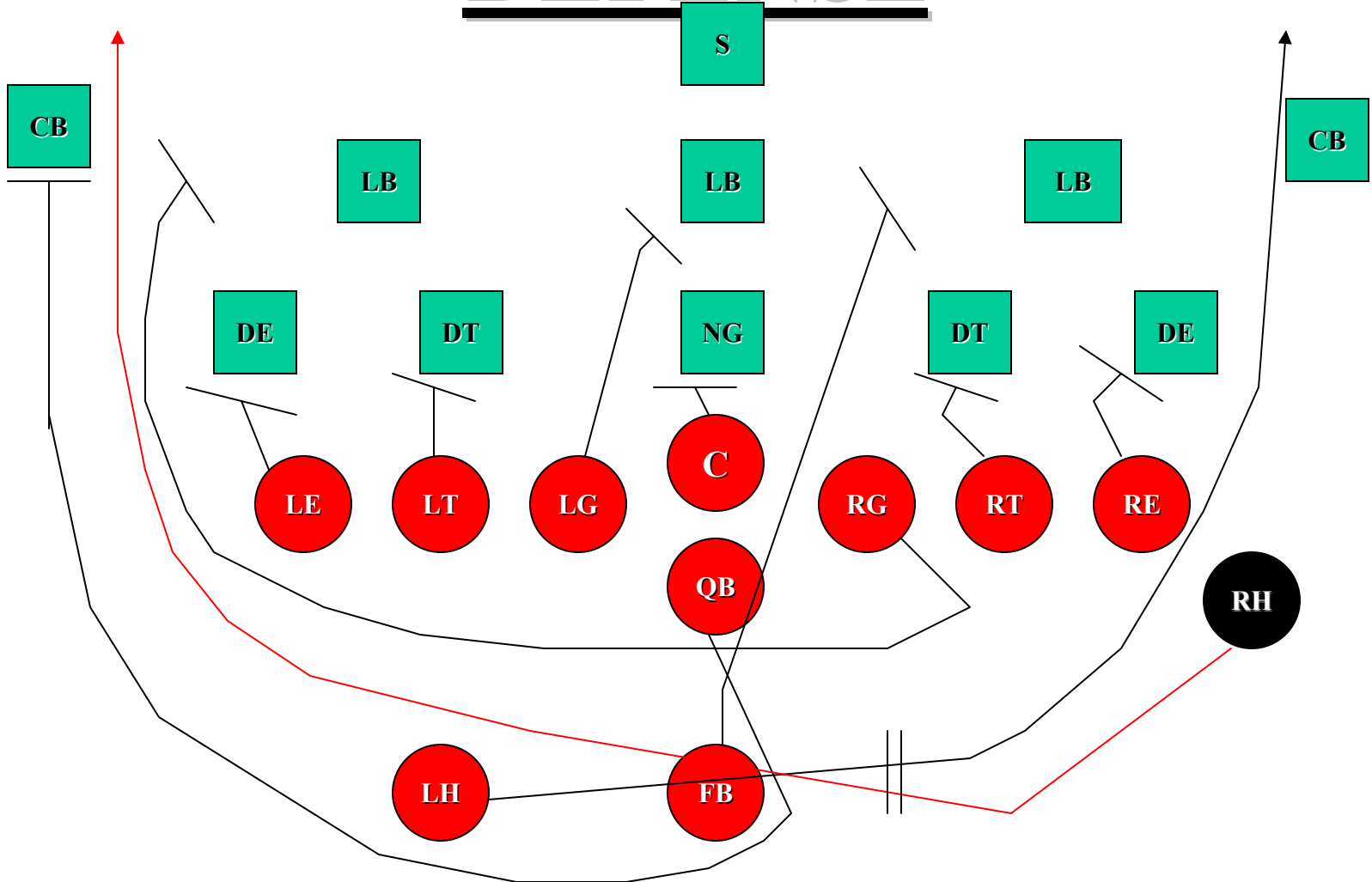

229 HALF REVERSE VS. 7-1

DEFENSE

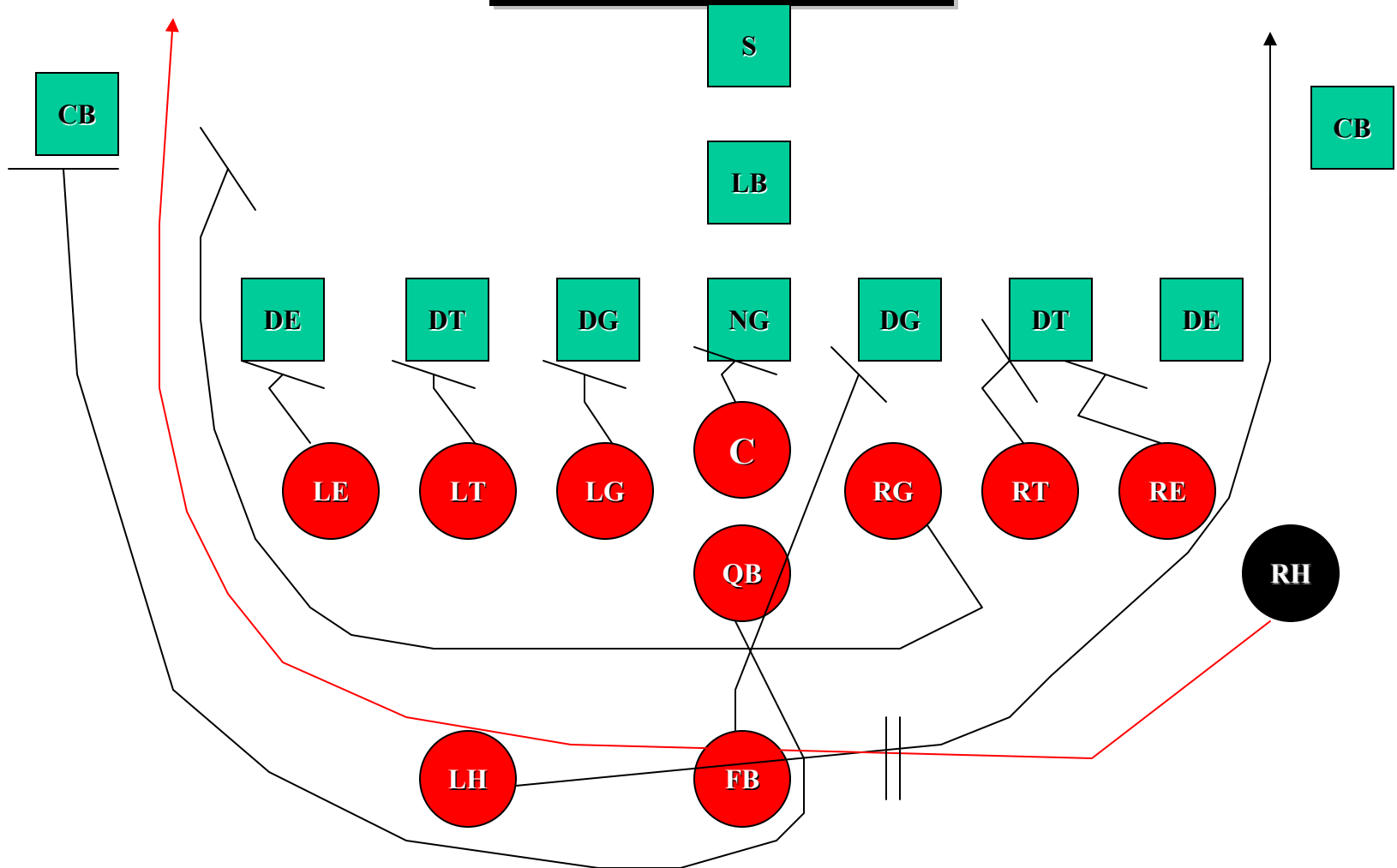

229 HALF REVERSE VS. 6-1

DEFENSE

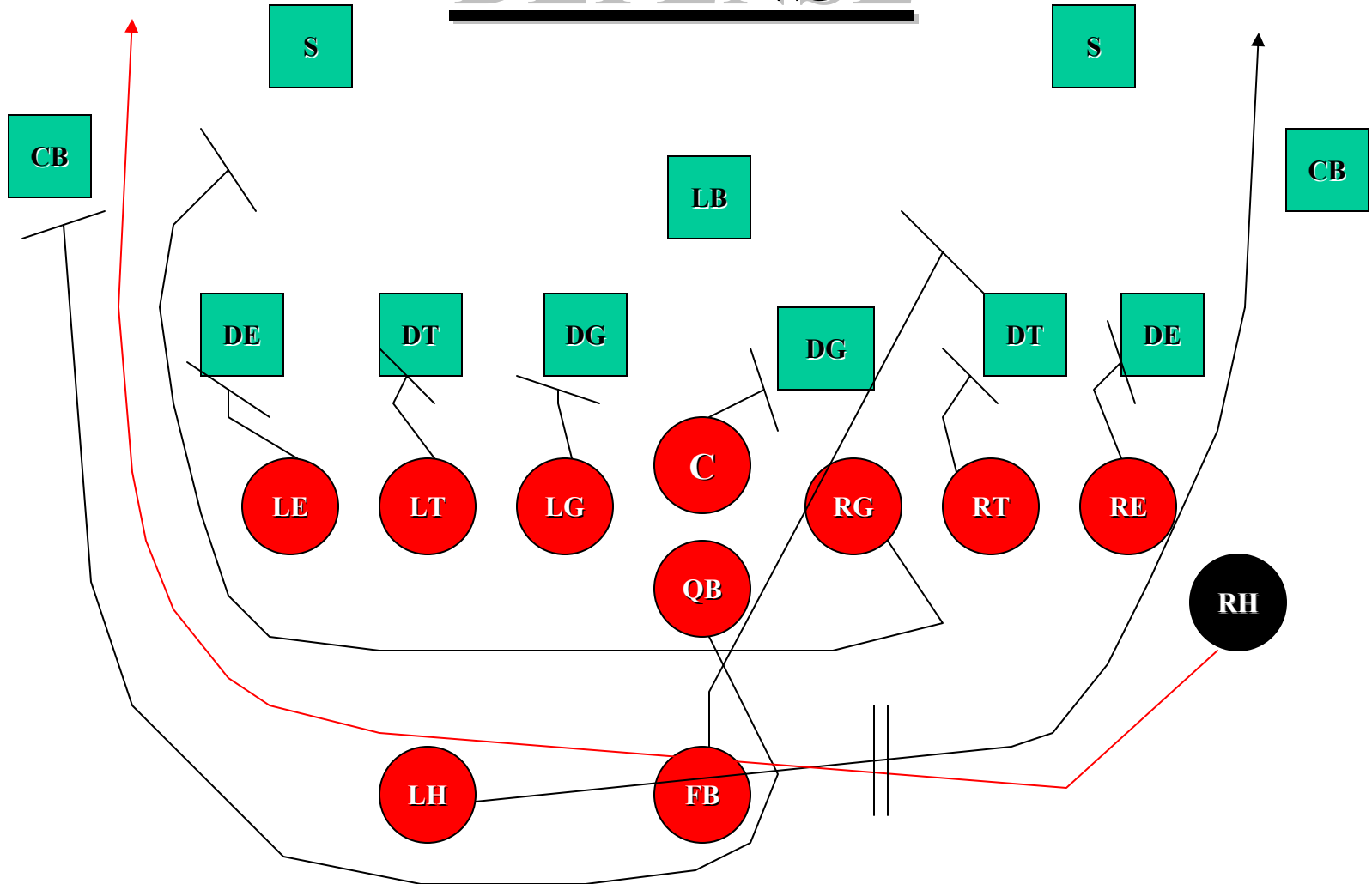

229 HALF REVERSE VS. 6-2

DEFENSE

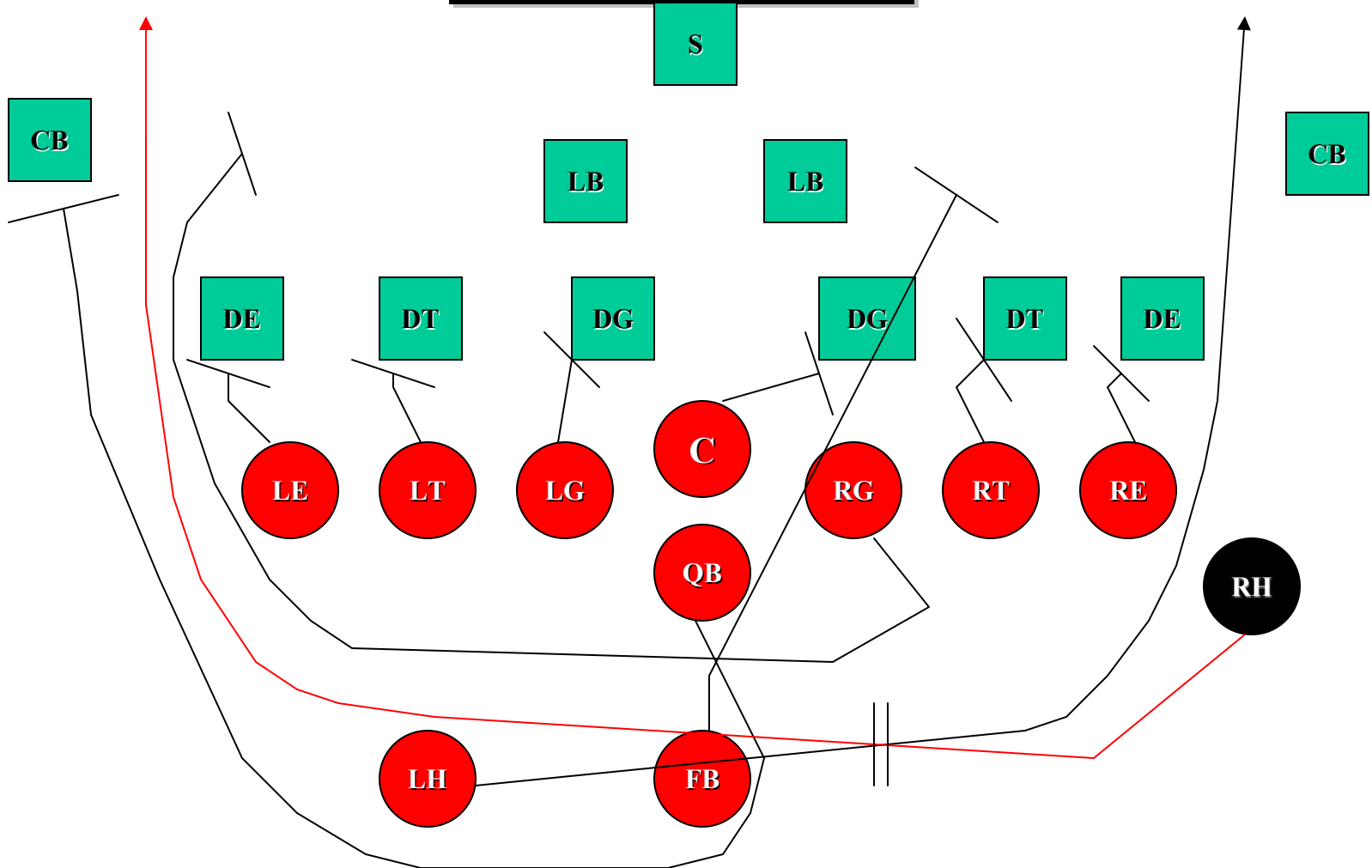

229 HALF REVERSE VS. 6-5

DEFENSE

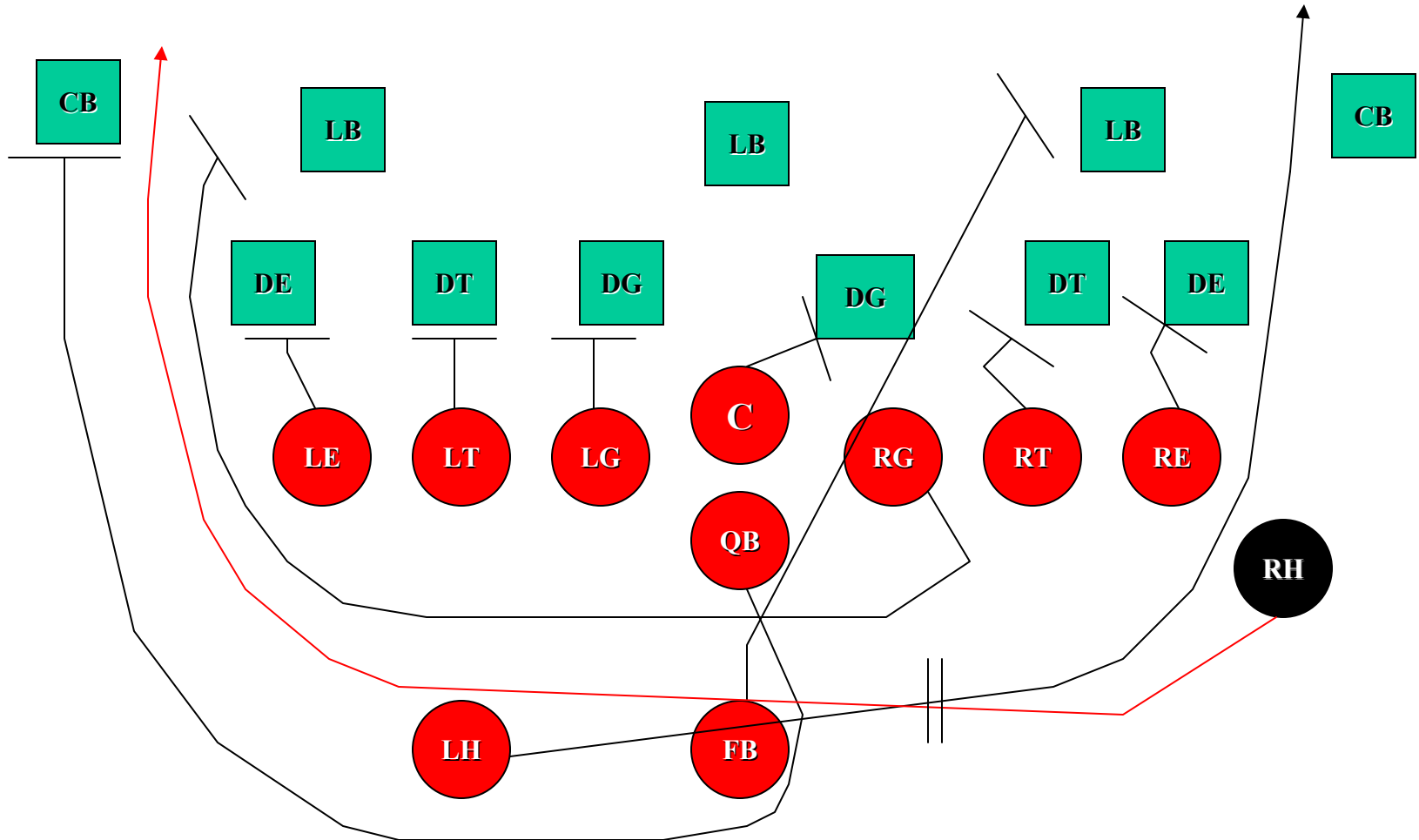

229 HALF REVERSE VS. 4-3

DEFENSE

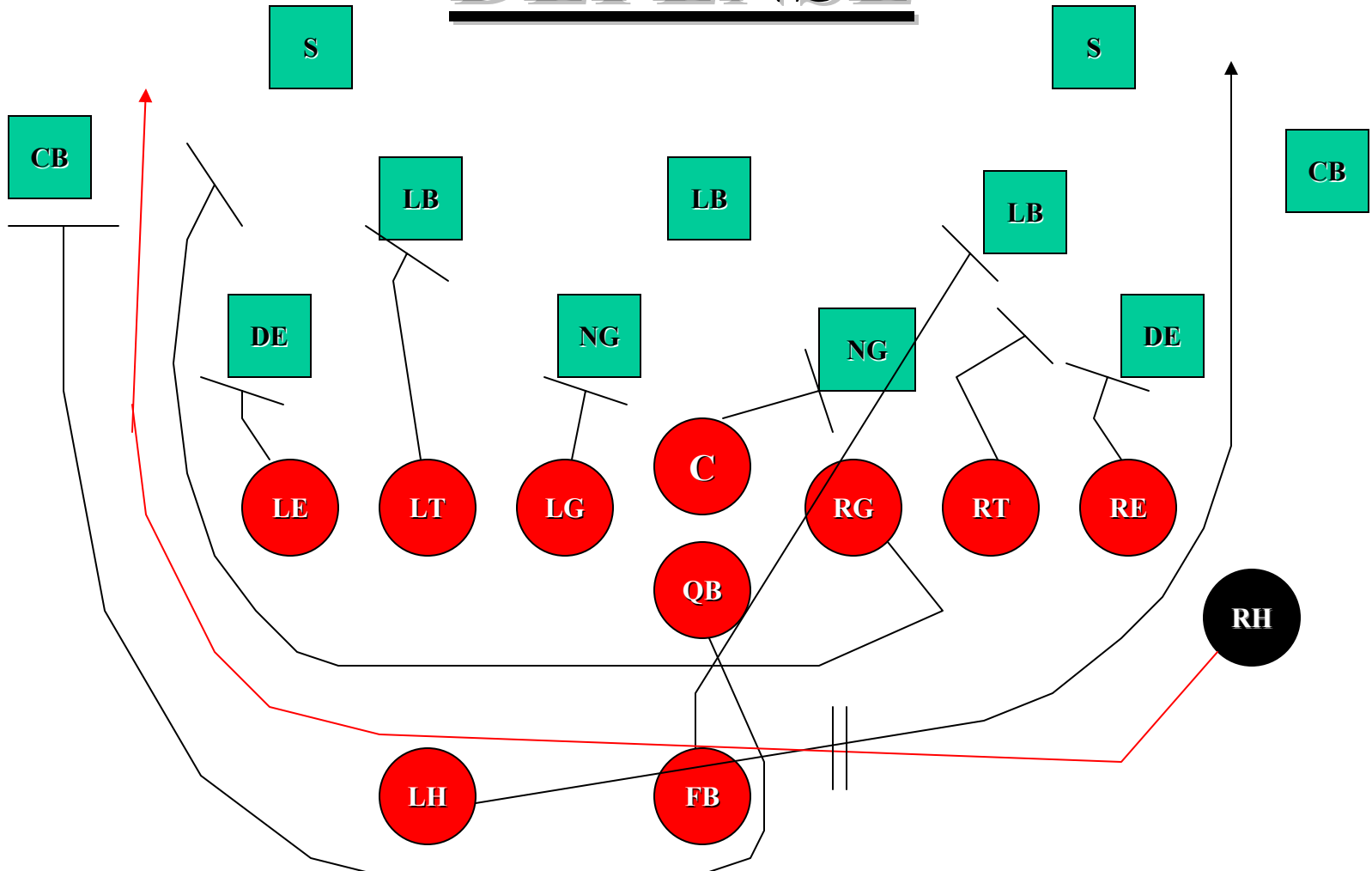

229 HALF REVERSE VS. 4-4

DEFENSE

